

INJ. PUMP CALIBRATION DATA

ENGINE MODEL ZB (Perkins)

1/4
 BOSCH No. 9 460 610 094
 DKKC No. 104564-2120
 Date: 20 Nov. 1986
 Company: MAZDA
 No. 3998-13-800

INJ. Pump general Assy No

Bosch type No. NP-EP/VM690A1800ARNP21

1. Test Conditions

Pump rotation : Clockwise viewed from drive side
 Nozzle, N. Holder Assy No.: 105780-8060
 Nozzle No.: 105780-0000 (BOSCH TYPE No. DN12SD12T)
 Nozzle Holder No.: 105780-2010 (BOSCH TYPE No. EF8511NP1)
 Nozzle opening pressure : 150 kg/cm²
 Transfer pump press.: 0.4 kg/cm²
 Injection pipe No.: 157805-0320
 Inner Dia. 2 mm X Outer Dia. 6 mm X Length 840 mm
 Test Oil : ISO 4113 or SAE standard test oil (SAE J967d)
 Oil Temp : 40⁺5°C
 Injection order: A - B - C - D - E - F

2. Approximate Adjustment

Move the control lever fully toward the maximum-speed side and, with the pump running at 1500 rpm, position the full-load setting screw to obtain an injection quantity of approx. 50cc/1000 strokes.

3. Adjustment of Delivery & Pump Chamber Pressure.

Pump speed : rpm	250	1000	1500	
Transfer pump press : kg/cm ²	2.2-3.0	5.2-6.0	6.6-7.4	
Pump chamber press : kg/cm ²			0.5-0.9	

4. Timing Advance Adjustment

Pump speed : rpm	1055-1255	1500	1800	
Timer piston stroke : mm	1.0	4.5-5.4	7.6-8.6	

5. Injection Quantity

Adj. point	Pump speed (rpm)	Injection Q'ty (cc/1000st)	Max. var bet. cyl (%)	Control lever position	Remarks
1	1500	42.0-43.0	Below ±2.0	Max. speed	Full load setting
2	1800	39.2-42.2	—	Max. speed	Full load confirmation
3	1000	38.8-41.8	—	Max. speed	Full load confirmation
4	200	7.0-13.0	Below ±2.0	below Idle	Governor shaft setting
5	100	Above 80		Max. speed	Excessive fuel for starting
6	225	23.0-30.0		↗	Supply of excessive fuel for starting finishes
7	1925	26.6-34.6		↗	Control lever Maximum speed setting
8	1975	8.4-26.4		↗	Speed droop
9	2100	Below 5		↗	Confirmation
10					
11					

6. Stop Lever Stopping Position Adjustment.

Run the pump at 50rpm with the control lever held in the Maximum-speed position. Check that the stop lever is capable of moving at least 3 mm, measured from the pin on the tip of the stop lever, from the non-injection position.

Adjust the spring capsule to limit the stop lever stroke to 2 mm from the non-injection position, and secure the capsule in that position.

7. Verifying Lever Position for Non-injection.

- (1) Run the pump at 50 rpm with the control lever held in the maximum-speed position.
- (2) Then, position the stop lever in the stop position.
- (3) In the above condition confirm that non-injection can be obtained, and confirm that the stop lever can move more than 1° from the non-injection.



DIESEL KIKI

DIESEL KIKI CO., LTD.
Service Department

3-6-7 SHIBUYA, SHIBUYA-KU, TOKYO 150, JAPAN
Tel. (03) 400-1551 Fax: (03) 499-4115

104564-2120 3/4

ADJUSTMENTS TO BE MADE DURING REASSEMBLY.

(1) Timer Piston Stroke

Fix the timer piston in the center position, and check that the following clearances for the piston stroke are available: 3.7 ± 0.2 on the advance side (the spring side); 4.5 ± 0.2 on the retard side (the opposite end).

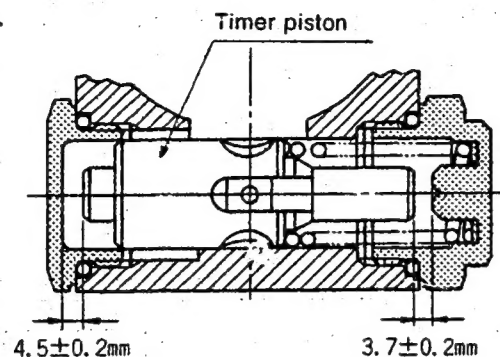

(2) Driving Shaft Clearance

Adjust the driving shaft shim so that the driving shaft's axial clearance is within the range of 0.1~0.2mm.

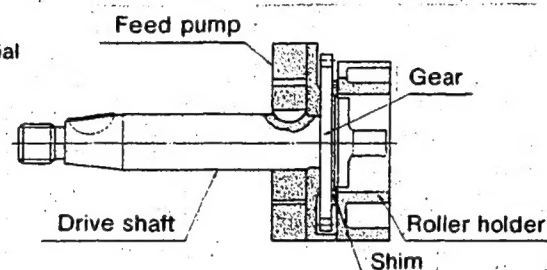

(3) Governor

Adjust, as follows, the distance between the center of the lever shaft and the governor spring seat:

* While pulling up the knob of the governor adjusting device, insert the shaft into the shaft hole provided in the pump housing. Be sure to position the shaft so that its flat side faces the fly-weight side.

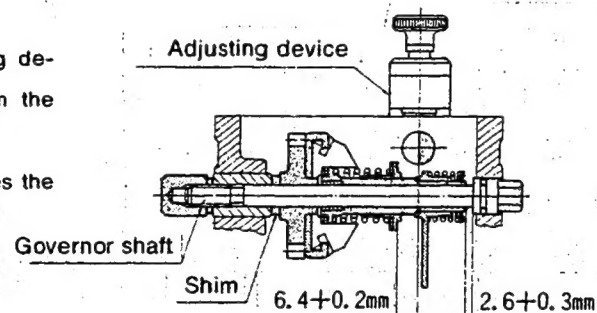

* Using a pair of calipers, measure the distance between the shaft's flat side and governor's spring seat and, as necessary, adjust this distance. The distance must be 6.4 ± 0.2 , measured while the governor spring seat is pushed toward the governor side.

* Adjust the governor sleeve stroke to 2.6 ± 0.3 , measured with the sleeve stroke gauge attached to the rear face of the flyweight holder. Reposition the governor shaft to obtain the prescribed stroke.

104564-2120 4/4

(4) Plunger

Replace the plunger spring with the spacer, and adjust the distance between the end face of the plunger and the distributor barrel to 13.5 ± 0.1 mm by adjusting the shim.

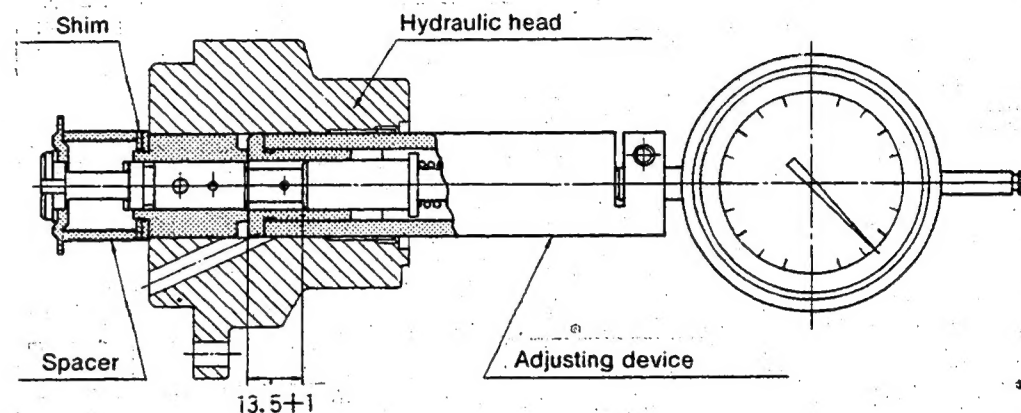

* Next, replace the spacer with the plunger spring and secure the hydraulic head to the pump housing. Then, readjust the distance to the above value by adjusting the shim.

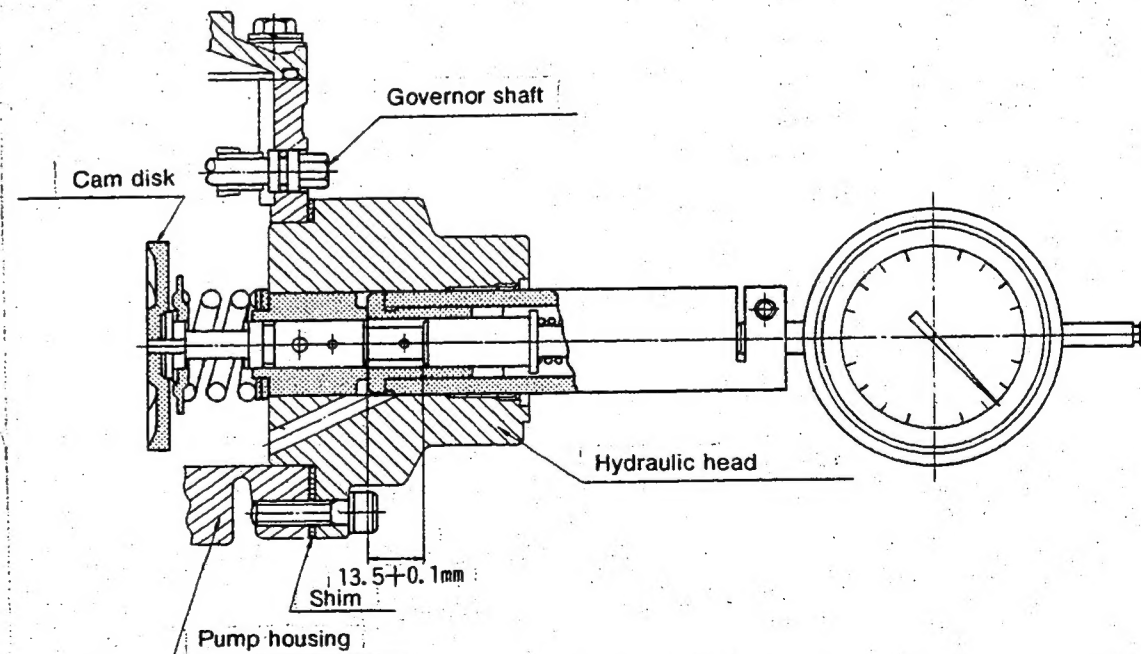

INJ. PUMP CALIBRATION DATA

TEST OIL:
I S O 4113 or
S A E J967d

Distributor-type

ENGINE MODEL : C223-T

BOSCH No.9 460 610 099

DKKC No. 104740-1021

Date : 20.Nov.1986

Company : ISUZU

No. 894132 3371

Injection pump No: 104640-1021 (NP-VE4/10F2150RNP259)

Pump rotation : clockwise-viewed from drive side

For Test Condition see
Microfiche No.WP-210(N16)

Pre-stroke : — mm

1. Setting	Pump speed (rpm)	Settings	Charge-air Press(mmHg)	Difference in delivery(cc)
1-1 Timing device travel	1,250	3.5~ 3.9 (mm)	0	
1-2 Supply pump pressure	1,250	4.6~ 5.0 (kg/cm ²)	0	
1-3 Full load delivery	1,250	47.8~48.8 (cc/1,000st)	590~610	4.0
1-4 Idle speed ragulation	375	9.3~13.3 (cc/1,000st)	0	2.0
1-5 Start	100	Above 60.0 (cc/1,000st)	0	
1-6 Full-load speed reguration	2,550	19.9~25.9 (cc/1,000st)	590~610	7.0
1-7 CSD Adjustment	500~700	Cancel speed		
1-8				

○ CSD Adjustment

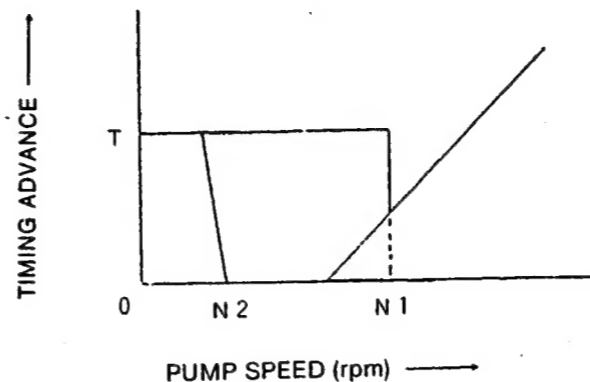

N 1 (Cancel).....500~700rpm
N 2.....Below 280rpm
T.....2.3~2.7mm

Upon canceling of CSD check the rerolution and make sure no fuel leakage from the overflow of CSD

2. Test Specifications

2-1 Timing device	N = rpm	1,250	1,700	2,150
	mm	3.4~ 4.0	5.8~ 6.8	8.7~ 9.4
2-2 Supply pump	N = rpm	250	1,250	2,000
	kg/cm ²	1.6~ 2.2	4.6~ 5.0	6.1~ 6.7
2-3 Overflow delivery	N = rpm	1,000		
	cc/10s	40.8~84.2		

Speed control lever	Pump speed (rpm)	Fuel delivery (cc/1,000st)	Charge-air Press(mmHg)	Difference in delivery
End stop	1,250	47.3~49.3	590~610	
	600	34.1~39.1	0	
	900	42.7~44.7	290~310	
	1,150	46.5~51.5	590~610	
	1,250	34.1~39.1	0	
	2,000	38.4~43.4	590~610	
	2,175	36.7~41.7	590~610	
	2,550	19.4~26.4	590~610	
Switch OFF	375	0	0	
	450	Below 3.0	0	
Idle stop	375	9.3~13.3	0	
	450	Below 3.0	0	

3. Dimensions

K	3.2~3.4	mm
KF	5.7~5.9	mm
MS	1.5~1.7	mm
BCS	3.4~3.6	mm

Control lever angle

α	21.0~27.0	deg
A	9.2~11.0	mm
β	37.0~47.0	deg
B	12.0~15.0	mm
Y	—	deg
C	—	mm

2-5 Solenoid Voltage : 12 V



DIESEL KIKI CO., LTD.
Service Department

3-6-7 SHIBUYA, SHIBUYA-KU, TOKYO 150, JAPAN
Tel. (03) 400-1551 Fax: (03) 499-4115

INJ. PUMP CALIBRATION DATA

Distributor-type

TEST OIL:
ISO 4113 or
SAE J967d

ENGINE MODEL : C223-T

Injection pump No: 104640-1022 [NP-VE4/10F2150RNP259]

BOSCH No. 9 460 610 127
DKKG No. 104740-1022
Date: 20.Nov.1986 0
Company: ISUZU
No. 894132 3372

Pump rotation : clockwise-viewed from drive side
Pre-stroke : — mm

For Test Condition see
Microfiche No.WP-210(N16)

1. Setting	Pump speed (rpm)	Settings	Charge-air Press(mmHg)	Difference in delivery(cc)
1-1	1,250	3.5~ 3.9 (mm)	0	
1-2	1,250	4.6~ 5.0 (kg/cm ²)	0	
1-3	1,250	47.8~48.8 (cc/1,000st)	590~610	4.0
1-4	375	9.3~13.3 (cc/1,000st)	0	2.0
1-5	100	Above 60.0 (cc/1,000st)	0	
1-6	2,550	19.9~25.9 (cc/1,000st)	590~610	7.0
1-7	500~700	Cancel speed		
1-8				

2. Test Specifications

2-1	Timing device	N = rpm	1,250	1,700	2,150
		mm	3.4~ 4.0	5.8~ 6.8	8.7~ 9.4
2-2	Supply pump	N = rpm	250	1,250	2,000
		kg/cm ²	1.6~ 2.2	4.6~ 5.0	6.1~ 6.7
2-3	Overflow delivery	N = rpm	1,000		
		cc/10s	40.8~84.2		

2-4 Fuel deliveries

Speed control lever	Pump speed (rpm)	Fuel delivery (cc/1,000st)	Charge-air Press(mmHg)	Difference in delivery
End stop	1,250	47.3~49.3	590~610	
	600	34.1~39.1	0	
	900	42.7~44.7	290~310	
	1,150	46.5~51.5	590~610	
	1,250	34.1~39.1	0	
	2,000	38.4~43.4	590~610	
	2,175	36.7~41.7	590~610	
	2,550	19.4~26.4	590~610	
	2,800	Below 7.0	590~610	
Switch OFF	375	0	0	
Idle stop	375	9.3~13.3	0	
	450	Below 3.0	0	

3. Dimensions

K	3.2~3.4	mm
KF	5.7~5.9	mm
MS	1.5~1.7	mm
BCS	3.4~3.6	mm
Control lever angle		
α	21.0~27.0	deg
A	9.2~11.0	mm
β	37.0~47.0	deg
B	12.0~15.0	mm
γ	—	deg
C	—	mm

2-5 Solenoid Voltage : 12 V

○ CSD Adjustment

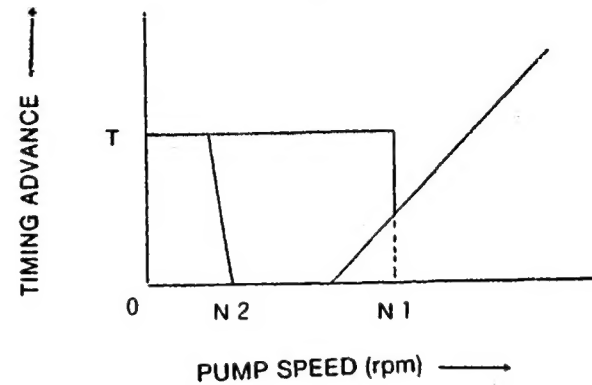

N1 (Cancel).....500~700rpm
N2.....Below 280rpm
T.....2.3~2.7mm

Upon canceling of CSD check the revolution and make sure no fuel leakage from the overflow of CSD

INJ.PUMP CALIBRATION DATA

○ CSD Adjustment

TEST OIL:
ISO 4113 or
SAE J967d

Distributor-type

ENGINE MODEL : C223-T

BOSCH No.9 460 610 131
DKKC No. 104740-1121
Date : 20.Nov.1986 Q
Company : ISUZU
No. 8941248571

Injection pump No: 104640-1022 (NP-VE4/10F2150RNP259)

Pump rotation : clockwise-viewed from drive side

For Test Condition see
Microfiche No.WP-210(N16)

Pre-stroke : - mm

1. Setting	Pump speed (rpm)	Settings	Charge-air Press(mmHg)	Difference in delivery(cc)
1-1 Timing device travel	1,250	3.5~ 3.9 (mm)	0	
1-2 Supply pump pressure	1,250	4.6~ 5.0 (kg/cm ²)	0	
1-3 Full load delivery	1,250	47.8~48.8 (cc/1,000st)	590~610	4.0
1-4 Idle speed regulation	375	9.3~13.3 (cc/1,000st)	0	2.0
1-5 Start	100	Above 60 (cc/1,000st)	0	
1-6 Full-load speed regulation	2,550	19.9~25.9 (cc/1,000st)	590~610	7.0
1-7 CSD Adjustment	500~700	Cancel speed		
1-8				

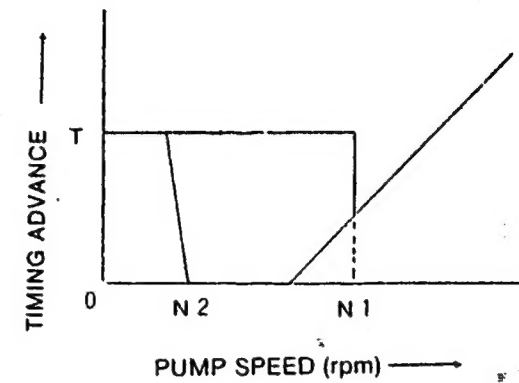

N 1 (Cancel).....500~700rpm
N 2Below 280rpm
T.....2.3~2.7mm

Upon canceling of CSD check the revolution and make sure no fuel leakage from the overflow of CSD

2. Test Specifications

2-1 Timing device	N = rpm	1,250	1,700	2,150
	mm	3.4~ 4.0	5.8~ 6.8	8.7~ 9.4
2-2 Supply pump	N = rpm	250	1,250	2,000
	kg/cm ²	1.6~ 2.2	4.6~ 5.0	6.1~ 6.7
2-3 Overflow delivery	N = rpm	1,000		
	cc/10s	40.8~84.2		

2-4 Fuel deliveries

Speed control lever	Pump speed (rpm)	Fuel delivery (cc/1,000st)	Charge-air Press(mmHg)	Difference in delivery
End stop	1,250	47.3~49.3	590~610	
	600	34.1~39.1	0	
	900	42.7~44.7	290~310	
	1,150	46.5~51.5	590~610	
	1,250	34.1~39.1	0	
	2,000	38.4~43.4	590~610	
	2,175	36.7~41.7	590~610	
	2,550	19.4~26.4	590~610	
Switch OFF	375	0	0	
	450	Below 3	0	
Idle stop	375	9.3~13.3	0	
	450	Below 3	0	

3. Dimensions

K	3.2~3.4	mm
KF	5.7~5.9	mm
MS	1.5~1.7	mm
BCS	3.4~3.6	mm

Control lever angle

α	21.0~27.0	deg
A	9.2~11.2	mm
β	37.0~47.0	deg
B	12.0~15.0	mm
γ	—	deg
C	—	mm

2-5 Solenoid Voltage : 12 V

INJ. PUMP CALIBRATION DATA

TEST OIL:
I S O 4113 or
S A E J967d

Distributor-type

ENGINE MODEL : 4FC1-T

Injection pump No: 104640-1180 [NP-VE4/10F2250RNP272]

BOSCH No.9 460 610 183

DKKC No. 104740-1280

Date : 20.Nov.1986 Q

Company : ISUZU

No. 894418 5201

Pump rotation : clockwise-viewed from drive side

Pre-stroke : - mm

For Test Condition see
Microfiche No.WP-210(N16)

1. Setting	Pump speed (rpm)	Settings	Charge air press(mmHg)	Difference in delivery(cc)
1-1 Timing device travel	1,250	2.7~ 3.1 (mm)		
1-2 Supply pump pressure	1,250	4.3~ 4.7 (kg/cm ²)		
1-3 Full load delivery with charge air pressure	1,250	46.0~47.0 (cc/1,000st)	470~490	4.0
Full load delivery with charge air pressure	900	38.5~39.5 (cc/1,000st)	256~276	
1-4 Idle speed regulation	330	9.6~13.6 (cc/1,000st)		2.0
1-5 Start	100	50.0~70.0 (cc/1,000st)		
1-6 Full-load speed regulation	2,600	18.0~24.0 (cc/1,000st)	470~490	3.0
1-7				
1-8				

INJ. PUMP CALIBRATION DATA

TEST OIL:
I S O 4113 or
S A E J967d

Distributor-type

ENGINE MODEL : 4FC1-T

Injection pump No: 104640-1180 [NP-VE4/10F2250RNP272]

BOSCH No.9 460 610 184

DKKC No. 104740-1290

Date : 20.Nov.1986 Q

Company : ISUZU

No. 894418 5211

Pump rotation : clockwise-viewed from drive side

Pre-stroke : - mm

For Test Condition see
Microfiche No.WP-210(N16)

1. Setting	Pump speed (rpm)	Settings	Charge air press(mmHg)	Difference in delivery(cc)
1-1 Timing device travel	1,250	2.7~ 3.1 (mm)		
1-2 Supply pump pressure	1,250	4.3~ 4.7 (kg/cm ²)		
1-3 Full load delivery with charge air pressure	1,250	46.0~47.0 (cc/1,000st)	470~490	4.0
Full load delivery with charge air pressure	900	38.5~39.5 (cc/1,000st)	256~276	
1-4 Idle speed regulation	330	9.6~13.6 (cc/1,000st)		2.0
1-5 Start	100	50.0~70.0 (cc/1,000st)		
1-6 Full-load speed regulation	2,600	18.0~24.0 (cc/1,000st)	470~490	3.0
1-7				
1-8				

2. Test Specifications

2-1 Timing device	N = rpm mm	1,250 2.6~ 3.2	2,275 7.0~ 7.8
2-2 Supply pump	N = rpm kg/cm ²	600 2.6~ 3.2	1,250 4.3~ 4.7
2-3 Overflow delivery	N = rpm cc/10s	1,250 45.0~88.0	2,250 7.1~ 7.7

2-4 Fuel deliveries

Speed control lever	Pump speed (rpm)	Fuel delivery (cc/1,000st)	Charge air press(mmHg)	Difference in delivery
End stop	1,250	28.4~33.4	0	
	1,250	45.5~47.5	470~490	
	600	28.2~32.2	0	
	900	38.0~40.0	256~276	
	2,000	38.3~43.3	470~490	
	2,250	35.4~40.4	470~490	
	2,600	17.5~24.5	470~490	
	2,850	Below 5.5	470~490	
Switch OFF	330	0		
Idle stop	330	9.6~13.6	0	
	400	Below 3.0	0	

2-5 Solenoid Max.cut-in voltage : 8 V
Test voltage : 12~14 V

3. Dimensions

K	3.2~3.4 mm
KF	5.7~5.9 mm
MS	1.1~1.3 mm
BCS	4.5~4.7 mm

Control lever angle

α	-24.5~-16.5 deg
A	10.1~12.7 mm
β	38.0~48.0 deg
B	12.2~15.5 mm
γ	- deg
C	- mm

2. Test Specifications

2-1 Timing device	N = rpm mm	1,250 2.6~ 3.2	2,275 7.0~ 7.8
2-2 Supply pump	N = rpm kg/cm ²	600 2.6~ 3.2	1,250 4.3~ 4.7
2-3 Overflow delivery	N = rpm cc/10s	1,250 45.0~88.0	2,250 7.1~ 7.7

2-4 Fuel deliveries

Speed control lever	Pump speed (rpm)	Fuel delivery (cc/1,000st)	Charge air press(mmHg)	Difference in delivery
End stop	1,250	28.4~33.4	0	
	1,250	45.5~47.5	470~490	
	600	28.2~32.2	0	
	900	38.0~40.0	256~276	
	2,000	38.3~43.3	470~490	
	2,250	35.4~40.4	470~490	
	2,600	17.5~24.5	470~490	
	2,850	Below 5.5	470~490	
Switch OFF	330	0		
Idle stop	330	9.6~13.6	0	
	400	Below 3.0	0	

2-5 Solenoid Max.cut-in voltage : 8 V
Test voltage : 12~14 V

3. Dimensions

K	3.2~3.4 mm
KF	5.7~5.9 mm
MS	1.1~1.3 mm
BCS	4.5~4.7 mm

Control lever angle

α	-24.5~-16.5 deg
A	10.1~12.7 mm
β	38.0~48.0 deg
B	12.2~15.5 mm
γ	- deg
C	- mm

INJ. PUMP CALIBRATION DATA

TEST OIL:
I S O 4113 or
S A E J967d

Distributor-type

ENGINE MODEL : 4FC1-T

Injection pump No: 104640-1180 [NP-VE4/10F2250RNP272]

BOSCH No.9 460 610 185
DKKC No. 104740-1300
Date : 20.Nov.1986 (0)
Company : ISUZU
No. 894405 6382

Pump rotation : clockwise-viewed from drive side
Pre-stroke : - mm

For Test Condition see
Microfiche No.WP-210(N16)

1. Setting	Pump speed (rpm)	Settings	Charge air press(mmHg)	Difference in delivery(cc)
1-1 Timing device travel	1,250	2.7~3.1 (mm)		
1-2 Supply pump pressure	1,250	4.3~4.7 (kg/cm ²)		
1-3 Full load delivery with charge air pressure	1,250	46.0~47.0 (cc/1,000st)	470~490	4.0
Full load delivery with charge air pressure	900	38.5~39.5 (cc/1,000st)	256~276	
1-4 Idle speed regulation	330	9.6~13.6 (cc/1,000st)		2.0
1-5 Start	100	50.0~70.0 (cc/1,000st)		
1-6 Full-load speed regulation	2,600	18.0~24.0 (cc/1,000st)	470~490	3.0
1-7				
1-8				

2. Test Specifications

2-1 Timing device	N = rpm mm	1,250 2.6~3.2	2,275 7.0~7.8
2-2 Supply pump	N = rpm kg/cm ²	600 2.6~3.2	1,250 4.3~4.7
2-3 Overflow delivery	N = rpm cc/10s	1,250 45.0~88.0	2,250 7.1~7.7

Speed control lever	Pump speed (rpm)	Fuel delivery (cc/1,000st)	Charge air press(mmHg)	Difference in delivery
End stop	1,250	28.4~33.4	0	
	1,250	45.5~47.5	470~490	
	600	28.2~32.2	0	
	900	38.0~40.0	256~276	
	2,000	38.3~43.3	470~490	
	2,250	35.4~40.4	470~490	
	2,600	17.5~24.5	470~490	
	2,850	Below 5.5	470~490	
Switch OFF	330	0		
Idle stop	330	9.6~13.6	0	
	400	Below 3.0	0	

2-5 Solenoid Max.cut-in voltage : 8 V
Test voltage : 12~14 V

3. Dimensions

K	3.2~3.4	mm
KF	5.7~5.9	mm
MS	1.1~1.3	mm
BCS	4.5~4.7	mm
Control lever angle		
α	-24.5~-16.5	deg
A	10.1~12.7	mm
β	38.0~48.0	deg
B	12.2~15.5	mm
Y	—	deg
C	—	mm

INJ. PUMP CALIBRATION DATA

TEST OIL:
I S O 4113 or
S A E J967d

Distributor-type

ENGINE MODEL : 4FC1-T

Injection pump No: 104640-1180 [NP-VE4/10F2250RNP272]

BOSCH No.9 460 610 186
DKKC No. 104740-1310
Date : 20.Nov.1986 (0)
Company : ISUZU
No. 894418 5232

Pump rotation : clockwise-viewed from drive side
Pre-stroke : - mm

For Test Condition see
Microfiche No.WP-210(N16)

1. Setting	Pump speed (rpm)	Settings	Charge air press(mmHg)	Difference in delivery(cc)
1-1 Timing device travel	1,250	2.7~3.1 (mm)		
1-2 Supply pump pressure	1,250	4.3~4.7 (kg/cm ²)		
1-3 Full load delivery with charge air pressure	1,250	46.0~47.0 (cc/1,000st)	470~490	4.0
Full load delivery with charge air pressure	900	38.5~39.5 (cc/1,000st)	256~276	
1-4 Idle speed regulation	330	9.6~13.6 (cc/1,000st)		2.0
1-5 Start	100	50.0~70.0 (cc/1,000st)		
1-6 Full-load speed regulation	2,600	18.0~24.0 (cc/1,000st)	470~490	3.0
1-7				
1-8				

2. Test Specifications

2-1 Timing device	N = rpm mm	1,250 2.6~3.2	2,275 7.0~7.8
2-2 Supply pump	N = rpm kg/cm ²	600 2.6~3.2	1,250 4.3~4.7
2-3 Overflow delivery	N = rpm cc/10s	1,250 45.0~88.0	2,250 7.1~7.7

Speed control lever	Pump speed (rpm)	Fuel delivery (cc/1,000st)	Charge air press(mmHg)	Difference in delivery
End stop	1,250	28.4~33.4	0	
	1,250	45.5~47.5	470~490	
	600	28.2~32.2	0	
	900	38.0~40.0	256~276	
	2,000	38.3~43.3	470~490	
	2,250	35.4~40.4	470~490	
	2,600	17.5~24.5	470~490	
	2,850	Below 5.5	470~490	
Switch OFF	330	0		
Idle stop	330	9.6~13.6	0	
	400	Below 3.0	0	

2-5 Solenoid Max.cut-in voltage : 8 V
Test voltage : 12~14 V

3. Dimensions

K	3.2~3.4	mm
KF	5.7~5.9	mm
MS	1.1~1.3	mm
BCS	4.5~4.7	mm
Control lever angle		
α	-24.5~-16.5	deg
A	10.1~12.7	mm
β	38.0~48.0	deg
B	12.2~15.5	mm
Y	—	deg
C	—	mm

INJ. PUMP CALIBRATION DATA

TEST OIL:
ISO 4113 or
SAE J967d

Distributor-type

ENGINE MODEL : LD20-T

Injection pump No: 104640-2042 (NP-VE4/10F2400RNP201)

BOSCH No.9 460 610 178

DKKC No. 104740-2042

Date: 20.Nov.1986

Company: NISSAN

No. 16700 08E10

For Test Condition see
Microfiche No.WP-210(N16)

Pump rotation : clockwise-viewed from drive side

Pre-stroke : mm

1. Setting	Pump speed (rpm)	Settings	Charge-air Press(mmHg)	Difference in delivery(cc)
1-1 Timing device travel	900	2.3~ 2.9 (mm)	245~265	
1-2 Supply pump pressure	900	2.9~ 3.5 (kg/cm ²)	245~265	
1-3 Full load delivery	600	29.9~30.9 (cc/1,000st)	0	2.5
1-4 Idle speed regulation	325	4.5~ 7.5 (cc/1,000st)	0	3.0
1-5 Start	100	40.0~50.0 (cc/1,000st)	0	
1-6 Full-load speed regulation	2,700	6.7~12.7 (cc/1,000st)	500~520	
1-7 Full-load delivery	900	37.0~38.0 (cc/1000st)	245~265	
1-8				

2. Test Specifications

2-1 Timing device	N = rpm	900	1,200	2,400
	mm	2.2~ 3.0	3.6~ 4.8	8.9~ 9.8
2-2 Supply pump	N = rpm	900	1,200	2,400
	kg/cm ²	2.8~ 3.6	3.4~ 4.2	6.5~ 7.3
2-3 Overflow delivery	N = rpm	1,000		
	cc/10s	36.0~80.0		

2-4 Fuel deliveries

Speed control lever	Pump speed (rpm)	Fuel delivery (cc/1,000st)	Charge-air Press(mmHg)	Difference in delivery
End stop	900	36.5~38.5	245~265	
	600	29.4~31.4	0	
	2,200	35.0~40.0	500~520	
	2,700	6.2~13.2	500~520	
	2,800	Below 6.0	500~520	
Switch OFF	325	0	0	
Idle stop	325	4.0~ 8.0	0	
Partial load	900	7.0~17.0	245~265	

2-5 Solenoid Voltage : 12 V

3. Dimensions

K	3.2 ~3.4	mm
KF	5.65~5.85	mm
MS	0.4 ~0.6	mm
BCS	3.9 ~4.1	mm

Control lever angle

α	21.0~29.0	deg
A	7.6~11.7	mm
β	36.0~46.0	deg
B	11.2~14.6	mm
γ	10.5~11.5	deg
C	5.7~6.3	mm

Adjustment of the W-CSD.

- Adjusting timing device advance angle (refer to Fig.1.3.)
By means of the screw ① adjust the timing device advance angle so that the value of timing device travel is that from the graph in fig 3.

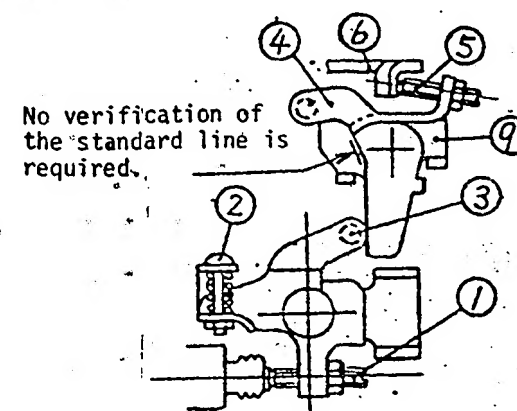

Fig 1

No verification of the standard line is required.

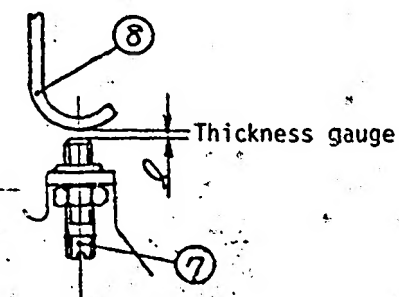
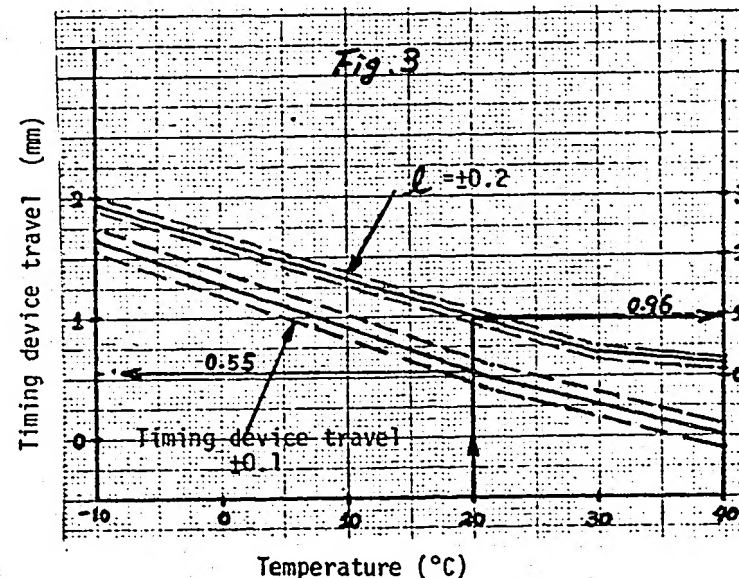

Fig.2



Dimension: L
Clearance between control lever and idle stopper bolt

2) Setting intermediate lever position (refer to figs 1 and 2.)

Insert the thickness gauge $l = 0.9 \pm 0.05$ mm between the idle set screw (7) and the control lever (8). When the top edge of the roller of the intermediate lever (4) is positioned at from the top edge of the bracket (6), tighten the screw (5) temporarily so that it contacts the control lever (8).

3) Adjustment of the W-CSD lever (refer to Figs 1 and 2.)

Insert the thickness gauge $l \pm 0.05$ obtained from the graph in Fig 3 between the idle set screw (7) and the control lever (8) and tighten the screw (2) at the position where the roller of the W-CSD lever (3) contacts the intermediate lever (4).

(The temperature of WAX should be less than 30°C during adjustment.)

NOTE:

When inserting the thickness gauge allow a gap between the lever (3) and (4) by means of the screw (2) so that the levers from much force.

Fig.4

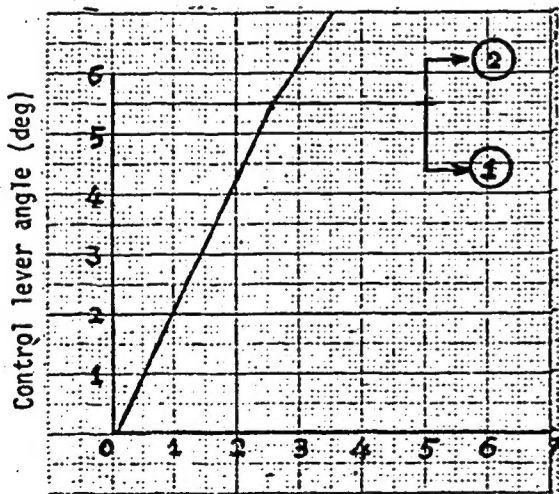

Dimension: l mm
Control lever

4) W-CSD specification

For control lever angle refer to Fig 4.

Dimension = l

① Angle = $2.1246 \cdot l$

② Angle = $1.6375 \cdot l + 1.252$

Dash-Pot Adjustment

Insert the Block gauge $l = 3.8 \pm 0.05$ mm between idle set screw (3) and bracket (4).

Adjust the Dash-Pot adjusting screw (1) to touch the push-rod (5), then tighten the lock-nut (2).

Note: Tightening torque: $T = 0.6$ to 0.9 Kg-m

- A: Check Alignment between adjusting screw (1) and push rod (5).
- B: Control lever must return to the idle position smoothly.

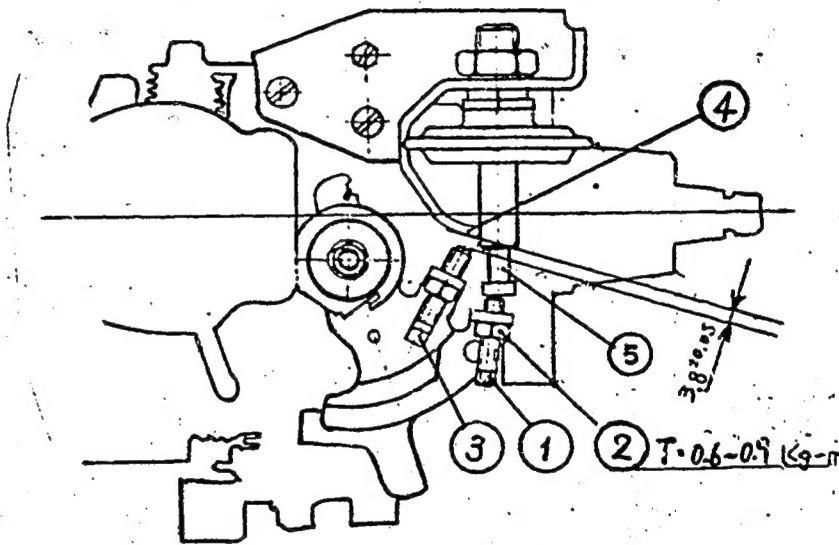

Adjustment of stop lever bolt to obtain adequate fuel delivery for engine starting.

Adjust the bolt shown in below picture and get fuel delivery as specified for engine starting and then fix bolt tightly. (refer page 1/3)

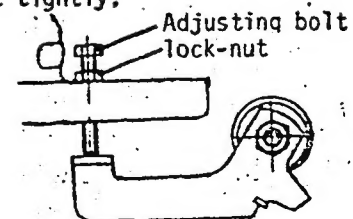

INJ. PUMP CALIBRATION DATA Distributor-type

TEST OIL:
I S O 4113 or
S A E J967d

ENGINE MODEL : 4D55T

BOSCH No.9 460 610 033

DKKC No. 104740-3100

Date : 20.Nov.1986 0

Company : MITSUBISHI

No. MD060178

Injection pump No: 104640-3060 (NP-VE4/10F2100RNP149)

Pump rotation : clockwise-viewed from drive side

For Test Condition see
Microfiche No.WP-210(N16)

Pre-stroke : — mm

1. Setting	Pump speed (rpm)	Settings	Charge air press(mmHg)	Difference in delivery(cc)
1-1 Timing device travel	850	1.1~1.5 (mm)	0	
1-2 Supply pump pressure	1,250	4.5~5.1 (kg/cm ²)	0	
1-3 Full load delivery without charge air pressure Full load delivery with charge air pressure	600	32.7~33.7 (cc/1,000st)	0	2.5
	750	36.2~37.2 (cc/1,000st)	100~120	
1-4 Idle speed regulation	375	6.4~10.4 (cc/1,000st)	0	2.5
1-5 Start	700	66.0~86.0 (cc/1,000st)	0	
1-6 Full-load speed regulation	2,650	19.1~25.2 (cc/1,000st)	615~635	6.5
1-7				
1-8				

2. Test Specifications

2-1 Timing device	N = rpm mm	850 1.1~1.5	1,750 6.1~7.3	2,100 7.8~8.6
2-2 Supply pump	N = rpm kg/cm ²	600 2.9~3.5	1,250 4.5~5.1	2,100 6.5~7.1
2-3 Overflow delivery	N = rpm cc/10s	1,250 58~102		
2-4 Fuel injection quantities				
Speed control lever position	Pump speed (rpm)	Fuel delivery (cc/1,000st)	Charge air press(mmHg)	Difference in delivery(cc)
Full speed position	600	32.2~34.2	0	
	750	35.7~37.7	100~120	
	1,250	49.3~53.3	468~488	
	2,100	42.8~47.8	615~635	
	2,650	18.1~26.1	615~635	
	3,050	Below 10	615~635	
Switch OFF	375	0		
Idling position	600	Below 3		
	375	6.4~10.4		
Partial load	600	14.5~26.5		
2-5 Solenoid	Max.cut-in voltage : 8 V Test voltage : 12~14 V			

3. Dimensions

K	3.2~3.4	mm
KF	5.7~5.9	mm
MS	0.8~1.0	mm
BCS	4.4~4.6	mm
Control lever angle		
α	55.0~63.0	deg
A	—	mm
β	41.0~51.0	deg
B	—	mm
γ	11.5~12.5	deg
C	—	mm

INJ. PUMP CALIBRATION DATA

Distributor-type

TEST OIL:
I S O 4113 or
S A E J967d

ENGINE MODEL : 4D55

BOSCH No.9 460 610 168

DKKC No. 104740-3480

Date : 20 Nov. 1986 Q

Company : MITSUBISHI

No. MD076156

104740-3480

Injection pump No: 104640-3240 (NP-VE4/10F2100RNP194)

Pump rotation : clockwise-viewed from drive side

For Test Condition see
Microfiche No.WP-210(N16)

Pre-stroke : - mm

1. Setting	Pump speed (rpm)	Settings	Charge air press(mmHg)	Difference in delivery(cc)
1-1 Timing device travel	1,000	2.1~ 2.5 (mm)		
1-2 Supply pump pressure	1,250	4.5~ 5.1 (kg/cm ²)		
1-3 Full load delivery without charge air pressure	1,250	39.2~40.2 (cc/1,000st)		3.0
Full load delivery with charge air pressure		(cc/1,000st)		
1-4 Idle speed regulation	375	6.5~ 9.5 (cc/1,000st)		2.0
1-5 Start	100	63.0~83.0 (cc/1,000st)	0	
1-6 Full-load speed regulation	2,550	10.1~16.1 (cc/1,000st)		4.0
1-7				
1-8				

■ FICD Mounting Position Adjustment

1. Hold the control lever in the idling position.
2. Position the FICD mounting bracket so that the gap between the control lever and the FICD

lever is 1+1 mm.

2. Test Specifications

2-1 Timing device	N = rpm mm	1,000 1.9~ 2.7	1,750 5.2~ 6.4	2,100 7.0~7.8
2-2 Supply pump	N = rpm kg/cm ²	600 2.9~ 3.5	1,250 4.5~ 5.1	2,100 6.5~ 7.1
2-3 Overflow delivery	N = rpm cc/10s	1,250 48.0~92.0		
2-4 Fuel injection quantities				
Speed control lever position	Pump speed (rpm)	Fuel delivery (cc/1,000st)	Charge air press(mmHg)	Difference in delivery(cc)
Full speed position	1,250	38.7~40.7		
	600	35.2~39.2		
	1,750	33.7~37.7		
	2,100	31.7~35.7		
	2,550	8.1~18.1		
	2,900	Below 3		
Switch OFF	375	0		
Idling position	600	Below 3		
	375	6.0~10.0		
2-5 Solenoid				
	Max.cut-in voltage : 8 V			
	Test voltage : 12~14 V			

3. Dimensions

K	3.2~3.4	mm
KF	5.7~5.9	mm
MS	1.3~1.5	mm
BCS	-	mm

Control lever angle

α	55.0~63.0	deg
A	10.5~16.0	mm
β	38.0~48.0	deg
B	11.5~15.5	mm
γ	-	deg
C	-	mm

INJ. PUMP CALIBRATION DATA
Distributor-type

TEST OIL:
I S O 4113 or
S A E J967d

ENGINE MODEL : 4D55

BOSCH No. 9 460 610 169
DKKC No. 104740-3500
Date : 20.Nov.1986
Company : MITSUBISHI
No. MD077708

Injection pump No: 104640-3250 [NP-VE4/10F2100RNP256]

For Test Condition see
Microfiche No.WP-210(N16)

Pump rotation : clockwise-viewed from drive side

Pre-stroke : - mm

1. Setting	Pump speed (rpm)	Settings	Charge air press(mmHg)	Difference in delivery(cc)
1-1 Timing device travel	1,000	2.1~ 2.5 (mm)		
1-2 Supply pump pressure	1,250	4.5~ 5.1 (kg/cm ²)		3.0
1-3 Full load delivery without charge air pressure	1,250	39.2~40.2 (cc/1,000st)		
Full load delivery with charge air pressure		(cc/1,000st)		
1-4 Idle speed regulation	375	6.5~ 9.5 (cc/1,000st)	0	2.0
1-5 Start	100	63.0~83.0 (cc/1,000st)		4.5
1-6 Full-load speed regulation	2,300	12.1~18.1 (cc/1,000st)		
1-7				
1-8				

■ FICD Mounting Position Adjustment

1. Hold the control lever in the idling position.
2. Position the FICD mounting bracket so that the gap between the control lever and the FICD lever is 1+1 mm.

2. Test Specifications

2-1 Timing device	N = rpm mm	1,000 1.9~ 2.7	1,750 5.2~ 6.4	2,100 7.0~7.8
2-2 Supply pump	N = rpm kg/cm ²	600 2.9~ 3.5	1,250 4.5~ 5.1	2,100 6.5~ 7.1
2-3 Overflow delivery	N = rpm cc/10s	1,250 48.0~92.0		
2-4 Fuel injection quantities				
Speed control lever position	Pump speed (rpm)	Fuel delivery (cc/1,000st)	Charge air press(mmHg)	Difference in delivery(cc)
Full speed position	1,250	38.7~40.7		
	600	35.2~39.2		
	1,750	33.7~37.7		
	2,100	31.7~35.7		
	2,300	10.1~20.1		
	2,500	Below 3		
Switch OFF	375	0		
Idling position	600	Below 3		
	375	6.0~10.0		
2-5 Solenoid	Max.cut-in voltage : 8 V Test voltage : 12~14 V			

3. Dimensions

K	3.2~3.4 mm
KF	5.7~5.9 mm
MS	1.3~1.5 mm
BCS	- mm

Control lever angle

α	55.0~63.0 deg
A	10.5~16.0 mm
β	38.0~48.0 deg
B	11.5~15.5 mm
γ	- deg
C	- mm

INJ. PUMP CALIBRATION DATA
Distributor-type

TEST OIL:
I S O 4113 or
S A E J967d

ENGINE MODEL : SD25

Injection pump No: 104640-4160 (NP-VE4/10F2100RNP112)

Pump rotation : clockwise-viewed from drive side

Pre-stroke : - mm

BOSCH No.9 460 610 048

DKKC No. 104740-4160

Date : 20.Nov.1986

Company : NISSAN DIESEL

No. 16700 T8212

For Test Condition see
Microfiche No.WP-210(N16)

1. Setting	Pump speed (rpm)	Settings	Charge air press(mmHg)	Difference in delivery(cc)
1-1 Timing device travel	1,000	1.5~ 1.9 (mm)		
1-2 Supply pump pressure	1,000	3.9~ 4.5 (kg/cm ²)		
1-3 Full load delivery without charge air pressure	1,000	37.9~38.9 (cc/1,000st)		3.0
Full load delivery with charge air pressure		(cc/1,000st)		
1-4 Idle speed regulation	300	4.5~ 8.5 (cc/1,000st)		2.0
1-5 Start	100	45.0~80.0 (cc/1,000st)		
1-6 Full-load speed regulation	2,250	11.7~17.7 (cc/1,000st)		
1-7				
1-8				

2. Test Specifications

2-1 Timing device	N = rpm mm	1,000 1.4~ 2.0	1,400 3.2~ 4.4	2,100 6.9~ 7.9
2-2 Supply pump	N = rpm kg/cm ²	600 2.9~ 3.5	1,000 3.9~ 4.5	2,100 6.6~ 7.2
2-3 Overflow delivery	N = rpm cc/10s	1,000 42~85		

2-4 Fuel injection quantities

Speed control lever position	Pump speed (rpm)	Fuel delivery (cc/1,000st)	Charge air press(mmHg)	Difference in delivery(cc)
Full speed position	1,000	37.4~39.4		
	600	31.2~35.2		
	2,100	32.9~37.1		
	2,250	11.2~18.2		
	2,350	Below 5		
Switch OFF	300	0		
Idling position	300	4.5~8.5		
	350	Below 3		

2-5 Solenoid Max.cut-in voltage : 8 V
Test voltage : 12~14 V

3. Dimensions

K	3.2~3.4 mm
KF	5.7~5.9 mm
MS	1.1~1.3 mm
BCS	- mm

Control lever angle

α	21.0~29.0 deg
A	6.0~9.2 mm
β	37.0~47.0 deg
B	14.7~14.8 mm
Y	- deg
C	- mm

INJ. PUMP CALIBRATION DATA
Distributor-type

TEST OIL:
I S O 4113 or
S A E J967d

ENGINE MODEL : SD23

Injection pump No: 104640-4231 (NP-VE4/10F2150RNP144)

Pump rotation : clockwise-viewed from drive side

Pre-stroke : - mm

BOSCH No.9 460 610 049

DKKC No. 104740-4231

Date : 20.Nov.1986

Company : NISSAN DIESEL

No. 16700 R8306

For Test Condition see
Microfiche No.WP-210(N16)

1. Setting	Pump speed (rpm)	Settings	Charge air press(mmHg)	Difference in delivery(cc)
1-1 Timing device travel	1,700	4.5~ 4.9 (mm)		
1-2 Supply pump pressure	1,700	5.6~ 6.2 (kg/cm ²)		
1-3 Full load delivery without charge air pressure	1,000	35.6~36.6 (cc/1,000st)		3.0
Full load delivery with charge air pressure		(cc/1,000st)		
1-4 Idle speed regulation	300	4.3~ 8.3 (cc/1,000st)		2.0
1-5 Start	100	55.0~90.0 (cc/1,000st)		
1-6 Full-load speed regulation	2,300	14.7~20.7 (cc/1,000st)		
1-7				
1-8				

2. Test Specifications

2-1 Timing device	N = rpm mm	1,000 1.4~ 2.6	1,700 4.4~ 5.0	2,150 6.1~ 7.1
2-2 Supply pump	N = rpm kg/cm ²	600 3.0~ 3.6	1,700 5.6~ 6.2	2,150 6.8~ 7.4
2-3 Overflow delivery	N = rpm cc/10s	1,000 41~85		

2-4 Fuel injection quantities

Speed control lever position	Pump speed (rpm)	Fuel delivery (cc/1,000st)	Charge air press(mmHg)	Difference in delivery(cc)
Full speed position	1,000	35.1~37.1		
	600	29.3~33.3		
	2,150	30.5~34.7		
	2,300	14.2~21.2		
	2,450	Below 5		
Switch OFF	300	0		
Idling position	300	4.3~8.3		
	350	Below 3		

2-5 Solenoid Max.cut-in voltage : 8 V
Test voltage : 12~14 V

3. Dimensions

K	3.2~3.4 mm
KF	5.7~5.9 mm
MS	1.4~1.6 mm
BCS	- mm

Control lever angle

α	21.0~29.0 deg
A	4.0~9.2 mm
β	41.0~51.0 deg
B	12.1~16.1 mm
Y	- deg
C	- mm

INJ. PUMP CALIBRATION DATA
Distributor-type

BOSCH No. 9 460 610 005
DKKC No. 104740-4260
Date: 20.Nov.1986
Company: NISSAN DIESEL
No. 16700 R8309

For Test Condition see
Microfiche No.WP-210(N16)

TEST OIL:
I S O 4113 or
S A E J967d

ENGINE MODEL : SD23

Injection pump No: 104640-4260 [NP-VE4/10F2000RNP147]

Pump rotation : clockwise-viewed from drive side

Pre-stroke : - mm

1. Setting	Pump speed (rpm)	Settings	Charge air press(mmHg)	Difference in delivery(cc)
1-1 Timing device travel	1,700	4.4~ 4.8 (mm)		3.0
1-2 Supply pump pressure	1,700	5.7~ 6.3 (kg/cm ²)		
1-3 Full load delivery without charge air pressure	1,000	35.6~36.6 (cc/1,000st)		
		(cc/1,000st)		2.0
1-4 Idle speed regulation	300	4.3~ 8.3 (cc/1,000st)		
1-5 Start	100	55.0~90.0 (cc/1,000st)		
1-6 Full-load speed regulation	2,300	10.6~14.6 (cc/1,000st)		
1-7				
1-8				

2. Test Specifications

2-1 Timing device	N = rpm mm	1,000 1.5~ 2.7	1,700 4.3~ 4.9	2,000 5.2~ 6.2
2-2 Supply pump	N = rpm kg/cm ²	600 3.2~ 3.8	1,700 5.7~ 6.3	2,000 6.5~ 7.1
2-3 Overflow delivery	N = rpm cc/10s	1,000 8.0~52		

2-4 Fuel injection quantities

Speed control lever position	Pump speed (rpm)	Fuel delivery (cc/1,000st)	Charge air press(mmHg)	Difference in delivery(cc)
Full speed position	1,000	35.1~37.1		
	600	29.3~33.3		
	2,000	30.5~34.7		
	2,300	10.1~15.1		
	2,450	Below 5		
Switch OFF	300	0		
Idling position	300	4.3~8.3		
	350	Below 3		

2-5 Solenoid Max.cut-in voltage : 8 V
Test voltage : 12~14 V

3. Dimensions

K	3.2~3.4 mm
KF	5.7~5.9 mm
MS	1.4~1.6 mm
BCS	- mm
Control lever angle	
α	21.0~29.0 deg
A	4.0~9.2 mm
β	37.0~47.0 deg
B	10.7~14.8 mm
Y	- deg
C	- mm

INJ. PUMP CALIBRATION DATA
Distributor-type

BOSCH No. 9 460 610 007
DKKC No. 104740-4300
Date: 20.Nov.1986
Company: NISSAN DIESEL
No. 16700 R8310

For Test Condition see
Microfiche No.WP-210(N16)

TEST OIL:
I S O 4113 or
S A E J967d

ENGINE MODEL : SD23

Injection pump No: 104640-4260 [NP-VE4/10F2000RNP147]

Pump rotation : clockwise-viewed from drive side

Pre-stroke : - mm

1. Setting	Pump speed (rpm)	Settings	Charge air press(mmHg)	Difference in delivery(cc)
1-1 Timing device travel	1,700	4.4~ 4.8 (mm)		3.0
1-2 Supply pump pressure	1,700	5.7~ 6.3 (kg/cm ²)		
1-3 Full load delivery without charge air pressure	1,000	35.6~36.6 (cc/1,000st)		
		(cc/1,000st)		2.0
1-4 Idle speed regulation	300	4.3~ 8.3 (cc/1,000st)		
1-5 Start	100	55.0~90.0 (cc/1,000st)		
1-6 Full-load speed regulation	2,300	10.6~14.6 (cc/1,000st)		
1-7				
1-8				

2. Test Specifications

2-1 Timing device	N = rpm mm	1,000 1.5~ 2.7	1,700 4.3~ 4.9	2,000 5.2~ 6.2
2-2 Supply pump	N = rpm kg/cm ²	600 3.2~ 3.8	1,700 5.7~ 6.3	2,000 6.5~ 7.1
2-3 Overflow delivery	N = rpm cc/10s	1,000 8.0~52		

2-4 Fuel injection quantities

Speed control lever position	Pump speed (rpm)	Fuel delivery (cc/1,000st)	Charge air press(mmHg)	Difference in delivery(cc)
Full speed position	1,000	35.1~37.1		
	600	29.3~33.3		
	2,000	30.5~34.7		
	2,300	10.1~15.1		
	2,450	Below 5		
Switch OFF	300	0		
Idling position	300	4.3~8.3		
	350	Below 3		

2-5 Solenoid Max.cut-in voltage : 8 V
Test voltage : 12~14 V

3. Dimensions

K	3.2~3.4 mm
KF	5.7~5.9 mm
MS	1.4~1.6 mm
BCS	- mm
Control lever angle	
α	21.0~29.0 deg
A	4.0~9.2 mm
β	37.0~47.0 deg
B	10.7~14.8 mm
Y	- deg
C	- mm

INJ. PUMP CALIBRATION DATA

Distributor-type

TEST OIL:
ISO 4113 or
SAE J967d

ENGINE MODEL : SD23

BOSCH No. 9 460 610 051
DKKC No. 104740-4360
Date : 20.Nov.1986 0
Company : NISSAN DIESEL
No. 16700 09W01

Injection pump No: 104640-4230 [NP-VE4/10F2150RNP144]
Pump rotation : clockwise-viewed from drive side
Pre-stroke : - mm

For Test Condition see
Microfiche No.WP-210(N16)

1. Setting	Pump speed (rpm)	Settings	Charge air press(mmHg)	Difference in delivery(cc)
1-1 Timing device travel	1,700	4.5~ 4.9 (mm)		
1-2 Supply pump pressure	1,700	5.6~ 6.2 (kg/cm ²)		
1-3 Full load delivery without charge air pressure	1,000	37.6~38.6 (cc/1,000st)		3.0
Full load delivery with charge air pressure		(cc/1,000st)		
1-4 Idle speed regulation	300	4.3~ 8.3 (cc/1,000st)		2.0
1-5 Start	100	55.0~90.0 (cc/1,000st)		
1-6 Full-load speed regulation	2,300	14.7~20.7 (cc/1,000st)		
1-7				
1-8				

2. Test Specifications

2-1 Timing device	N = rpm mm	1,000 1.4~ 2.6	1,700 4.4~ 5.0	2,150 6.1~ 7.1
2-2 Supply pump	N = rpm kg/cm ²	600 3.0~ 3.6	1,700 5.6~ 6.2	2,150 6.8~ 7.4
2-3 Overflow delivery	N = rpm cc/10s	1,000 41~85		

3. Dimensions

K	3.2~3.4	mm
KF	5.7~5.9	mm
MS	1.4~1.6	mm
BCS	-	mm

Control lever angle

α	21.0~29.0	deg
A	4.0~9.2	mm
β	41.0~51.0	deg
B	12.1~16.1	mm
Y	-	deg
C	-	mm

2-4 Fuel injection quantities	Speed control lever position	Pump speed (rpm)	Fuel delivery (cc/1,000st)	Charge air press(mmHg)	Difference in delivery(cc)
Full speed position		1,000	37.1~39.1		
		600	32.2~36.2		
		2,150	32.5~36.7		
		2,300	14.2~21.2		
		2,450	Below 5		
Switch OFF		300	0		
Idling position		300	4.3~8.3		
		350	Below 3		
2-5 Solenoid		Max.cut-in voltage : 8 V Test voltage : 12~14 V			

INJ. PUMP CALIBRATION DATA

Distributor-type

TEST OIL:
ISO 4113 or
SAE J967d

ENGINE MODEL : SD25

BOSCH No.9 460 610 010
DKKC No. 104740-4400
Date : 20.Nov.1986 0
Company : NISSAN DIESEL
No. 16700 54W03

Injection pump No: 104640-4400 [NP-VE4/10F2100RNP189]
Pump rotation : clockwise-viewed from drive side
Pre-stroke : - mm

For Test Condition see
Microfiche No.WP-210(N16)

1. Setting	Pump speed (rpm)	Settings	Charge air press(mmHg)	Difference in delivery(cc)
1-1 Timing device travel	1,000	1.5~ 1.9 (mm)		
1-2 Supply pump pressure	1,000	4.0~ 4.6 (kg/cm ²)		
1-3 Full load delivery without charge air pressure	1,000	40.6~41.6 (cc/1,000st)		3.5
Full load delivery with charge air pressure		(cc/1,000st)		
1-4 Idle speed regulation	300	4.5~ 8.5 (cc/1,000st)		2.0
1-5 Start	100	50.0~85.0 (cc/1,000st)		
1-6 Full-load speed regulation	2,250	11.7~17.7 (cc/1,000st)		
1-7				
1-8				

2. Test Specifications

2-1 Timing device	N = rpm mm	1,000 1.4~ 2.0	1,400 3.2~ 4.4	2,100 6.9~ 7.9
2-2 Supply pump	N = rpm kg/cm ²	600 3.1~ 3.7	1,000 4.0~ 4.6	2,100 6.6~ 7.2
2-3 Overflow delivery	N = rpm cc/10s	1,000 8.0~52		

2-4 Fuel injection quantities

Speed control lever position	Pump speed (rpm)	Fuel delivery (cc/1,000st)	Charge air press(mmHg)	Difference in delivery(cc)
Full speed position	1,000	40.1~42.1		
	600	35.7~39.7		
	2,100	34.1~38.3		
	2,250	11.2~18.3		
	2,350	Below 5		
Switch OFF	300	0		
Idling position	300	4.5~8.5		
	350	Below 3		
2-5 Solenoid		Max.cut-in voltage : 8 V Test voltage : 12~14 V		

3. Dimensions

K	3.2~3.4	mm
KF	5.7~5.9	mm
MS	1.1~1.3	mm
BCS	-	mm

Control lever angle

α	21.0~29.0	deg
A	4.0~9.2	mm
β	39.5~49.5	deg
B	11.6~15.6	mm
Y	-	deg
C	-	mm

INJ. PUMP CALIBRATION DATA Distributor-type

TEST OIL:
I S O 4113 or
S A E J967d

ENGINE MODEL : SD25

BOSCH No.9 460 610 052
DKKC No. 104740-4410
Date : 20.Nov.1986 [0]
Company : NISSAN DIESEL
No. 16700 54W04

Injection pump No: 104640-4400 [NP-VE4/10F2100RNP189]

Pump rotation : clockwise-viewed from drive side

For Test Condition see
Microfiche No.WP-210(N16)

Pre-stroke : - mm

1. Setting	Pump speed (rpm)	Settings	Charge air press(mmHg)	Difference in delivery(cc)
1-1 Timing device travel	1,000	1.5~ 1.9 (mm)		
1-2 Supply pump pressure	1,000	4.0~ 4.6 (kg/cm ²)		
1-3 Full load delivery without charge air pressure	1,000	40.6~41.6 (cc/1,000st)		3.5
Full load delivery with charge air pressure		(cc/1,000st)		
1-4 Idle speed regulation	300	4.5~ 8.5 (cc/1,000st)		2.0
1-5 Start	100	50.0~85.0 (cc/1,000st)		
1-6 Full-load speed regulation	2,250	11.7~17.7 (cc/1,000st)		
1-7				
1-8				

2. Test Specifications

2-1 Timing device	N = rpm mm	1,000 1.4~ 2.0	1,400 3.2~ 4.4	2,100 6.9~ 7.9
2-2 Supply pump	N = rpm kg/cm ²	600 3.1~ 3.7	1,000 4.0~ 4.6	2,100 6.6~ 7.2
2-3 Overflow delivery	N = rpm cc/10s	1,000 8.0~52		

2-4 Fuel injection quantities

Speed control lever position	Pump speed (rpm)	Fuel delivery (cc/1,000st)	Charge air press(mmHg)	Difference in delivery(cc)
Full speed position	1,000	40.1~42.1		
	600	35.7~39.7		
	2,100	34.1~38.3		
	2,250	11.2~18.3		
	2,350	Below 5		
Switch OFF	300	0		
Idling position	300	4.5~8.5		
	350	Below 3		

3. Dimensions

K	3.2~3.4 mm
KF	5.7~5.9 mm
MS	1.1~1.3 mm
BCS	- mm
Control lever angle	
α	21.0~29.0 deg
A	4.0~9.2 mm
β	39.5~49.5 deg
B	11.6~15.6 mm
Y	- deg
C	- mm

2-5 Solenoid Max.cut-in voltage : 8 V
Test voltage : 12~14 V

INJ. PUMP CALIBRATION DATA Distributor-type

TEST OIL:
I S O 4113 or
S A E J967d

ENGINE MODEL : SD25

BOSCH No.9 460 610 053
DKKC No. 104740-4420
Date : 20.Nov.1986 [0]
Company : NISSAN DIESEL
No. 16700 T8273

Injection pump No: 104640-4410 [NP-VE4/10F2100RNP275]

Pump rotation : clockwise-viewed from drive side

For Test Condition see
Microfiche No.WP-210(N16)

Pre-stroke : 0.26~0.30 mm

1. Setting	Pump speed (rpm)	Settings	Charge air press(mmHg)	Difference in delivery(cc)
1-1 Timing device travel	1,000	1.5~ 1.9 (mm)		
1-2 Supply pump pressure	1,000	3.9~ 4.5 (kg/cm ²)		
1-3 Full load delivery without charge air pressure	1,000	37.9~38.9 (cc/1,000st)		3.0
Full load delivery with charge air pressure		(cc/1,000st)		
1-4 Idle speed regulation	300	4.5~ 8.5 (cc/1,000st)		2.0
1-5 Start	100	45.0~80.0 (cc/1,000st)		
1-6 Full-load speed regulation	2,250	11.7~17.7 (cc/1,000st)		
1-7				
1-8				

2. Test Specifications

2-1 Timing device	N = rpm mm	1,000 1.4~ 2.0	1,400 2.7~ 3.9	2,100 5.6~ 6.8
2-2 Supply pump	N = rpm kg/cm ²	600 2.9~ 3.5	1,000 3.9~ 4.5	2,100 6.6~ 7.2
2-3 Overflow delivery	N = rpm cc/10s	1,000 41.0~85.0		

2-4 Fuel injection quantities

Speed control lever position	Pump speed (rpm)	Fuel delivery (cc/1,000st)	Charge air press(mmHg)	Difference in delivery(cc)
Full speed position	1,000	37.4~39.4		
	600	32.8~36.8		
	2,100	34.4~38.4		
	2,250	11.2~18.2		
	2,350	Below 5		
Switch OFF	300	0		
Idling position	300	4.5~ 8.5		
	350	Below 3		

3. Dimensions

K	3.2~3.4 mm
KF	5.7~5.9 mm
MS	1.1~1.3 mm
BCS	- mm
Control lever angle	
α	21.0~29.0 deg
A	4.0~9.2 mm
β	37.0~47.0 deg
B	10.7~14.8 mm
Y	- deg
C	- mm

2-5 Solenoid Max.cut-in voltage : 8 V
Test voltage : 12~14 V

INJ. PUMP CALIBRATION DATA
Distributor-type

TEST OIL:
I S O 4113 or
S A E J967d

ENGINE MODEL : SD25

BOSCH No.9 460 610 134

DKKC No. 104740-4460

Date : 20.Nov.1986 [Q]

Company : NISSAN DIESEL

No. 16700 T7204

Injection pump No: 104640-4450 [NP-VE4/10F2100RNP288]

Pump rotation : clockwise-viewed from drive side

Pre-stroke : 0.26~0.30 mm

For Test Condition see
Microfiche No.WP-210(N16)

1. Setting	Pump speed (rpm)	Settings	Charge air press(mmHg)	Difference in delivery(cc)
1-1 Timing device travel	1,000	1.5~ 1.9 (mm)		
1-2 Supply pump pressure	1,000	3.9~ 4.5 (kg/cm ²)		
1-3 Full load delivery without charge air pressure	1,000	37.9~38.9 (cc/1,000st)		3.0
Full load delivery with charge air pressure		(cc/1,000st)		
1-4 Idle speed regulation	300	4.5~ 8.5 (cc/1,000st)		2.0
1-5 Start	100	45.0~80.0 (cc/1,000st)		
1-6 Full-load speed regulation	2,350	11.7~17.7 (cc/1,000st)		
1-7				
1-8				

INJ. PUMP CALIBRATION DATA
Distributor-type

TEST OIL:
I S O 4113 or
S A E J967d

ENGINE MODEL : SD23

BOSCH No.9 460 610 135

DKKC No. 104740-4500

Date : 20.Nov.1986 [Q]

Company : NISSAN DIESEL

No. 16700 R8313

Injection pump No: 104640-4490 [NP-VE4/10F2150RNP295]

Pump rotation : clockwise-viewed from drive side

Pre-stroke : 0.18~0.22 mm

For Test Condition see
Microfiche No.WP-210(N16)

1. Setting	Pump speed (rpm)	Settings	Charge air press(mmHg)	Difference in delivery(cc)
1-1 Timing device travel	1,400	3.0~ 3.4 (mm)		
1-2 Supply pump pressure	1,700	5.6~ 6.2 (kg/cm ²)		
1-3 Full load delivery without charge air pressure	1,000	35.6~36.6 (cc/1,000st)		3.0
Full load delivery with charge air pressure		(cc/1,000st)		
1-4 Idle speed regulation	300	4.3~ 8.3 (cc/1,000st)		2.0
1-5 Start	100	55.0~90.0 (cc/1,000st)		
1-6 Full-load speed regulation	2,300	14.7~20.7 (cc/1,000st)		
1-7				
1-8				

2. Test Specifications

2-1 Timing device	N = rpm mm	1,000 1.4~ 2.0	1,400 2.7~ 3.9	2,100 5.6~ 6.8
2-2 Supply pump	N = rpm kg/cm ²	600 2.9~ 3.5	1,000 3.9~ 4.5	2,100 6.6~ 7.2
2-3 Overflow delivery	N = rpm cc/10s	1,000 4.1~85.0		

2-4 Fuel injection quantities

Speed control lever position	Pump speed (rpm)	Fuel delivery (cc/1,000st)	Charge air press(mmHg)	Difference in delivery(cc)
Full speed position	1,000	37.4~39.4		
	600	32.8~36.8		
	2,100	34.4~38.4		
	2,350	11.2~18.2		
	2,450	Below 5		
Switch OFF	300	0		
Idling position	300	4.5~8.5		
	350	Below 3		

3. Dimensions

K	3.2~3.4 mm
KF	5.7~5.9 mm
MS	1.1~1.3 mm
BCS	— mm

Control lever angle

α	21.0~29.0 deg
A	4.0~9.2 mm
β	37.0~47.0 deg
B	10.7~14.8 mm
γ	— deg
C	— mm

2-5 Solenoid Max.cut-in voltage : 8 V
Test voltage : 12~14 V

2. Test Specifications

2-1 Timing device	N = rpm mm	1,400 2.9~ 3.5	1,700 3.8~ 5.0	2,150 5.6~ 6.8
2-2 Supply pump	N = rpm kg/cm ²	600 3.0~ 3.6	1,700 5.6~ 6.2	2,150 6.8~ 7.4
2-3 Overflow delivery	N = rpm cc/10s	1,000 41~85		

2-4 Fuel injection quantities

Speed control lever position	Pump speed (rpm)	Fuel delivery (cc/1,000st)	Charge air press(mmHg)	Difference in delivery(cc)
Full speed position	1,000	35.1~37.1		
	600	30.3~34.3		
	2,150	31.9~35.9		
	2,300	14.2~21.2		
	2,450	Below 5		
Switch OFF	300	0		
Idling position	300	4.3~8.3		
	350	Below 3		

3. Dimensions

K	3.2~3.4 mm
KF	5.65~5.85 mm
MS	1.4~1.6 mm
BCS	— mm

Control lever angle

α	21.0~29.0 deg
A	4.0~9.2 mm
β	41.0~51.0 deg
B	12.1~16.1 mm
γ	— deg
C	— mm

2-5 Solenoid Max.cut-in voltage : 8 V
Test voltage : 12~14 V

INJ. PUMP CALIBRATION DATA Distributor-type

TEST OIL:
I S O 4113 or
S A E J967d

ENGINE MODEL : SD23

Injection pump No: 104640-4510 [NP-VE4/10F2150RNP297]

Pump rotation : clockwise-viewed from drive side

Pre-stroke : 0.18~0.22 mm

BOSCH No.9 460 610 136

DKKC No. 104740-4520

Date : 20.Nov.1986 [Q]

Company : NISSAN DIESEL

No. 16700 R8315

For Test Condition see
Microfiche No.WP-210(N16)

1. Setting	Pump speed (rpm)	Settings	Charge air press(mmHg)	Difference in delivery(cc)
1-1 Timing device travel	1,400	3.0~ 3.4 (mm)		
1-2 Supply pump pressure	1,700	5.6~ 6.2 (kg/cm ²)		
1-3 Full load delivery without charge air pressure	1,000	35.6~36.6 (cc/1,000st)		3.0
Full load delivery with charge air pressure		(cc/1,000st)		
1-4 Idle speed regulation	300	4.3~ 8.3 (cc/1,000st)		2.0
1-5 Start	100	55.0~90.0 (cc/1,000st)		
1-6 Full-load speed regulation	2,300	14.7~20.7 (cc/1,000st)		
1-7				
1-8				

2. Test Specifications

2-1 Timing device	N = rpm mm	1,400 2.9~ 3.5	1,700 3.8~ 5.0	2,150 5.6~ 6.8
2-2 Supply pump	N = rpm kg/cm ²	600 3.0~ 3.6	1,700 5.6~ 6.2	2,150 6.8~ 7.4
2-3 Overflow delivery	N = rpm cc/10s	1,000 8.0~52		

2-4 Fuel injection quantities

Speed control lever position	Pump speed (rpm)	Fuel delivery (cc/1,000st)	Charge air press(mmHg)	Difference in delivery(cc)
Full speed position	1,000	35.1~37.1		
	600	30.3~34.3		
	2,150	31.9~35.9		
	2,300	14.2~21.2		
	2,450	Below 5		
Switch OFF	300	0		
Idling position	300	4.3~8.3		
	350	Below 3		

3. Dimensions

K	3.2~3.4 mm
KF	5.65~5.85 mm
MS	1.4~1.6 mm
BCS	— mm
Control lever angle	
α	21.0~29.0 deg
A	4.0~9.2 mm
β	41.0~51.0 deg
B	12.1~16.1 mm
Y	— deg
C	— mm

2-5 Solenoid Max.cut-in voltage : 16 V
Test voltage : 24~26 V

INJ. PUMP CALIBRATION DATA Distributor-type

TEST OIL:
I S O 4113 or
S A E J967d

ENGINE MODEL : SD23

Injection pump No: 104640-4560 [NP-VE4/10F2150RNP312]

Pump rotation : clockwise-viewed from drive side

Pre-stroke : 0.18~0.22 mm

BOSCH No.9 460 610 137

DKKC No. 104740-4570

Date : 20.Nov.1986 [Q]

Company : NISSAN DIESEL

No. 16700 R8311

For Test Condition see
Microfiche No.WP-210(N16)

1. Setting	Pump speed (rpm)	Settings	Charge air press(mmHg)	Difference in delivery(cc)
1-1 Timing device travel	1,000	1.5~ 1.9 (mm)		
1-2 Supply pump pressure	1,000	3.9~ 4.5 (kg/cm ²)		
1-3 Full load delivery without charge air pressure	1,000	35.6~36.6 (cc/1,000st)		3.0
Full load delivery with charge air pressure		(cc/1,000st)		
1-4 Idle speed regulation	300	4.3~ 8.3 (cc/1,000st)		2.0
1-5 Start	100	55.0~90.0 (cc/1,000st)		
1-6 Full-load speed regulation	2,450	14.7~20.7 (cc/1,000st)		
1-7				
1-8				

2. Test Specifications

2-1 Timing device	N = rpm mm	1,000 1.4~ 2.0	1,400 2.6~ 3.8	2,150 5.6~ 6.8
2-2 Supply pump	N = rpm kg/cm ²	1,000 3.9~ 4.5	1,400 4.9~ 5.5	2,150 6.8~ 7.4
2-3 Overflow delivery	N = rpm cc/10s	1,000 41~85		

2-4 Fuel injection quantities

Speed control lever position	Pump speed (rpm)	Fuel delivery (cc/1,000st)	Charge air press(mmHg)	Difference in delivery(cc)
Full speed position	1,000	35.1~37.1		
	600	30.3~34.3		
	2,150	31.9~35.9		
	2,450	14.2~21.2		
	2,600	Below 5		
Switch OFF	300	0		
Idling position	300	4.3~8.3		
	350	Below 3		

3. Dimensions

K	3.2~3.4 mm
KF	5.65~5.85 mm
MS	1.4~1.6 mm
BCS	— mm
Control lever angle	
α	21.0~29.0 deg
A	4.0~9.2 mm
β	41.0~51.0 deg
B	12.1~16.1 mm
Y	— deg
C	— mm

2-5 Solenoid Max.cut-in voltage : 8 V
Test voltage : 12~14 V

INJ. PUMP CALIBRATION DATA Distributor-type

TEST OIL:
I S O 4113 or
S A E J967d

ENGINE MODEL : SD23

BOSCH No.9 460 610 138
DKKC No. 104740-4580
Date : 20.Nov.1986
Company : NISSAN DIESEL
No. 16700 R8312

For Test Condition see
Microfiche No.WP-210(N16)

Injection pump No: 104640-4570 (NP-VE4/10F215RNP313)

Pump rotation : clockwise-viewed from drive side

Pre-stroke : 0.18~0.22 mm

1. Setting	Pump speed (rpm)	Settings	Charge air press(mmHg)	Difference in delivery(cc)
1-1 Timing device travel	1,000	1.5~ 1.9 (mm)		
1-2 Supply pump pressure	1,000	4.0~ 4.6 (kg/cm ²)		
1-3 Full load delivery without charge air pressure	1,000	35.6~36.6 (cc/1,000st)		3.0
Full load delivery with charge air pressure		(cc/1,000st)		
1-4 Idle speed regulation	300	4.3~ 8.3 (cc/1,000st)		2.0
1-5 Start	100	55.0~90.0 (cc/1,000st)		
1-6 Full-load speed regulation	2,450	14.7~20.7 (cc/1,000st)		
1-7				
1-8				

2. Test Specifications

2-1 Timing device	N = rpm mm	1,000 1.4~ 2.0	1,400 2.6~ 3.8	2,150 5.6~ 6.8
2-2 Supply pump	N = rpm kg/cm ²	1,000 4.0~ 4.6	1,400 5.0~ 5.6	2,150 6.8~ 7.4
2-3 Overflow delivery	N = rpm cc/10s	1,000 8.0~52		

3. Dimensions

K	3.2~3.4 mm
KF	5.65~5.85 mm
MS	1.4~1.6 mm
BCS	— mm

Control lever angle

α	21.0~29.0 deg
A	4.0~9.2 mm
β	41.0~51.0 deg
B	12.1~16.1 mm
Y	— deg
C	— mm

2-4 Fuel injection quantities	Speed control lever position	Pump speed (rpm)	Fuel delivery (cc/1,000st)	Charge air press(mmHg)	Difference in delivery(cc)
	Full speed position	1,000	35.1~37.1		
		600	30.3~34.3		
		2,150	31.9~35.9		
		2,450	14.2~21.2		
		2,600	Below 5		
Switch OFF	300	0			
Idling position	300	4.3~8.3			
	350	Below 3			

2-5 Solenoid Max.cut-in voltage : 16 V
Test voltage : 24~26 V

INJ. PUMP CALIBRATION DATA Distributor-type

TEST OIL:
I S O 4113 or
S A E J967d

ENGINE MODEL : SD23

BOSCH No.9 460 610 139
DKKC No. 104740-4701
Date : 20.Nov.1986
Company : NISSAN DIESEL
No. 16700 18G02

Injection pump No: 104640-4681 (NP-VE4/10F2150RNP340)

Pump rotation : clockwise-viewed from drive side

Pre-stroke : 0.18~0.22 mm

For Test Condition see
Microfiche No.WP-210(N16)

1. Setting	Pump speed (rpm)	Settings	Charge air press(mmHg)	Difference in delivery(cc)
1-1 Timing device travel	1,000	1.5~ 1.9 (mm)		
1-2 Supply pump pressure	1,000	4.0~ 4.6 (kg/cm ²)		
1-3 Full load delivery without charge air pressure	1,000	35.6~36.6 (cc/1,000st)		3.0
Full load delivery with charge air pressure		(cc/1,000st)		
1-4 Idle speed regulation	300	4.3~ 8.3 (cc/1,000st)		2.0
1-5 Start	100	45.0~80.0 (cc/1,000st)		
1-6 Full-load speed regulation	2,450	14.7~20.7 (cc/1,000st)		
1-7				
1-8				

2. Test Specifications

2-1 Timing device	N = rpm mm	1,000 1.4~ 2.0	1,400 2.6~ 3.8	2,150 5.6~ 6.8
2-2 Supply pump	N = rpm kg/cm ²	1,000 4.0~ 4.6	1,400 5.0~ 5.6	2,150 6.8~ 7.4
2-3 Overflow delivery	N = rpm cc/10s	1,000 8.0~52.0		

2-4 Fuel deliveries

Speed control lever	Pump speed (rpm)	Fuel delivery (cc/1,000st)	Charge air press(mmHg)	Difference in delivery
End stop	2,600	Below 5.0		
	2,450	14.2~21.2		
	2,150	31.9~35.9		
	1,000	35.1~37.1		
	600	30.3~34.3		
Switch OFF	300	0		
Idle stop	300	4.3~ 8.3		
	350	Below 3.0		

3. Dimensions

K	3.2~3.4 mm
KF	5.65~5.85 mm
MS	1.1~1.3 mm
BCS	— mm

Control lever angle

α	21.0~29.0 deg
A	4.0~ 9.2 mm
β	41.0~51.0 deg
B	18.6~22.6 mm
Y	— deg
C	— mm

2-5 Solenoid Max.cut-in voltage : 8 V
Test voltage : 12~14 V

INJ. PUMP CALIBRATION DATA
Distributor-type

TEST OIL:
ISO 4113 or
SAE J967d

ENGINE MODEL : SD25

BOSCH No.9 460 610 140
DKKC No. 104740-4770
Date : 20.Nov.1986
Company : NISSAN DIESEL
No. 16700 37G02

104740-4770 2/3

Injection pump No: 104640-4770 [NP-VE4/10F2100RNP396]

Pump rotation : clockwise-viewed from drive side
Pre-stroke : 0.26~0.30 mm

For Test Condition see
Microfiche No.WP-210(N16)

1. Setting	Pump speed (rpm)	Settings	Charge air press(mmHg)	Difference in delivery(cc)
1-1 Timing device travel	1,000	1.5~ 1.9 (mm)		
1-2 Supply pump pressure	1,000	4.0~ 4.6 (kg/cm ²)		
1-3 Full load delivery without charge air pressure	1,000	39.9~40.9 (cc/1,000st)		3.0
Full load delivery with charge air pressure		(cc/1,000st)		
1-4 Idle speed regulation	300	4.3~ 8.3 (cc/1,000st)		2.0
1-5 Start	100	45.0~80.0 (cc/1,000st)		
1-6 Full-load speed regulation	2,350	11.7~17.7 (cc/1,000st)		
1-7				
1-8				

2. Test Specifications

2-1 Timing device	N = rpm	1,000	1,400	2,100
	mm	1.4~ 2.0	2.7~ 3.9	5.6~ 6.8
2-2 Supply pump	N = rpm	600	1,000	2,100
	kg/cm ²	3.1~ 3.7	4.0~ 4.6	6.6~ 7.2
2-3 Overflow delivery	N = rpm	1,000		
	cc/10s	8.0~52.0		

2-4 Fuel deliveries

Speed control lever	Pump speed (rpm)	Fuel delivery (cc/1,000st)	Charge air press(mmHg)	Difference in delivery
End stop	1,000	39.4~41.4		
	600	36.5~40.5		
	2,100	33.6~37.8		
	2,350	11.2~18.2		
	2,450	Below 5.0		
Switch OFF	300	0		
Idle stop	300	4.5~ 8.5		
	350	Below 3.0		

2-5 Solenoid Max.cut-in voltage : 8 V
Test voltage : 12~14 V

3. Dimensions

K	3.2 ~3.4 mm
KF	5.65~5.85 mm
MS	1.1 ~1.3 mm
BCS	— mm

Control lever angle

α	21.0~29.0 deg
A	4.0~ 9.2 mm
β	37.0~47.0 deg
B	10.7~14.8 mm
Y	— deg
C	— mm

■ W-CSD Adjustment

1) Timer stroke adjustment

1. Calculate the timer stroke from Fig. 2 according to the atmospheric temperature at the time of adjustment.
2. Adjust using timer stroke adjusting screw so that the timer stroke is as calculated in Step 1.

Step 1.

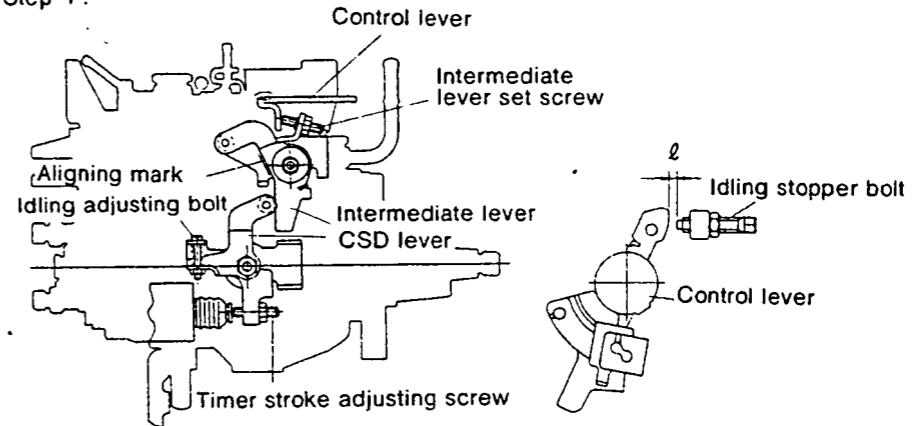

Formula for calculating Fig. 2

Fig 1.

Formula for calculating timer stroke:

When $-10 \leq t (^{\circ}\text{C}) \leq 20$ $T = -0.055t + 1.1$

When $20 \leq t (^{\circ}\text{C}) \leq 40$ $T = -0.0333t + 0.66$

Formula for calculating control lever and idling stopper bolt gap:

When $-10 \leq t (^{\circ}\text{C}) \leq 20$ $l = -0.0867t + 3.63$

When $20 \leq t (^{\circ}\text{C}) \leq 40$ $l = -0.075t + 3.4$

Gap between control lever and idling stopper bolt
Timer stroke

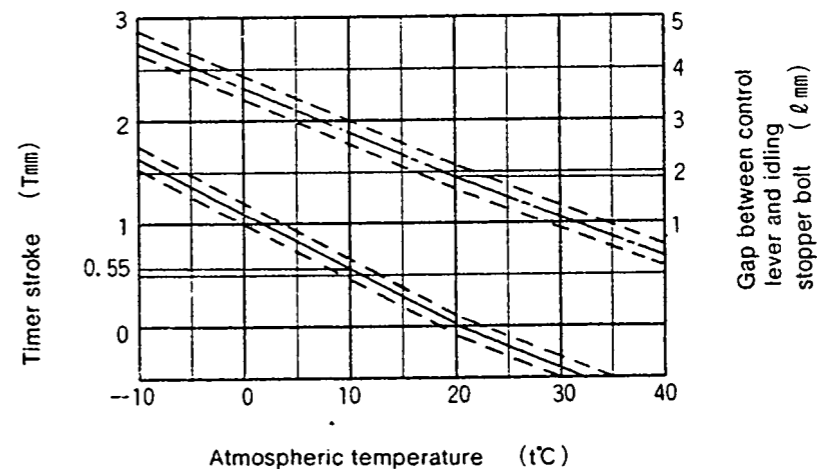

Fig 2.



DIESEL KIKI CO. LTD. 3-6-7 SHIBUYA, SHIBUYA-KU, TOKYO-150, JAPAN
Service Department Tel. (03) 400-1551 Fax: (03) 499-4115

2) Intermediate lever position adjustment

1. Insert a block gauge (thickness gauge) of 1.9 ± 0.05 mm thickness between the control lever and the idling stopper bolt.
2. Align the intermediate lever with the aligning mark .
3. Adjust the intermediate lever set screw so that the control lever and intermediate lever set screw are in contact, and then fix in position using the locknut.

3) CSD lever adjustment

1. Calculate the block gauge dimension $l \pm 0.05$ mm from Fig. 2 according to the atmospheric temperature at the time of adjustment.
2. Insert the block gauge (thickness gauge) between the control lever and the idling stopper bolt.
3. Using the idling bolt, adjust so that the CSD lever roller and intermediate lever are in contact.

Notes :

1. The temperature of the wax must be below 30°C when adjusting.
2. When inserting a block gauge (thickness gauge) between the control lever (beacket) and the idling stopper bolt, use the idling adjusting bolt to separate the CSD lever and intermediate lever so that no excessive force is exerted on them.

INJ. PUMP CALIBRATION DATA

TEST OIL:
ISO 4113 or
SAE J967d

Distributor-type

ENGINE MODEL : SD23

Injection pump No: 104640-4760 [NP-VE4/10F2150RNP395]

BOSCH No.9 460 610 141

DKKC No. 104740-4800

Date: 20.Nov.1986 [0]

Company: NISSAN DIESEL

No. 16700 23G03

104740-4800 2/3

Pump rotation : clockwise-viewed from drive side
Pre-stroke : 0.18~0.22 mm

For Test Condition see
Microfiche No.WP-210(N16)

1. Setting	Pump speed (rpm)	Settings	Charge air press(mmHg)	Difference in delivery(cc)
1-1 Timing device travel	1,000	1.5~ 1.9 (mm)		
1-2 Supply pump pressure	1,000	4.0~ 4.6 (kg/cm ²)		
1-3 Full load delivery without charge air pressure	1,000	35.6~36.6 (cc/1,000st)		3.0
Full load delivery with charge air pressure		(cc/1,000st)		
1-4 Idle speed regulation	300	4.3~ 8.3 (cc/1,000st)		2.0
1-5 Start	100	45.0~80.0 (cc/1,000st)		
1-6 Full-load speed regulation	2,450	14.7~20.7 (cc/1,000st)		
1-7				
1-8				

2. Test Specifications

2-1 Timing device	N = rpm	1,000	1,400	2,150
	mm	1.4~ 2.0	2.6~ 3.8	5.6~ 6.8
2-2 Supply pump	N = rpm	1,000	1,400	2,150
	kg/cm ²	4.0~ 4.6	5.0~ 5.6	6.8~ 7.4
2-3 Overflow delivery	N = rpm	1,000		
	cc/10s	8.0~52.0		

2-4 Fuel deliveries

Speed control lever	Pump speed (rpm)	Fuel delivery (cc/1,000st)	Charge air press(mmHg)	Difference in delivery
End stop	1,000	35.1~37.1		
	600	30.3~34.3		
	2,150	31.9~35.9		
	2,450	14.2~21.2		
	2,600	Below 5.0		
Switch OFF	300	0		
Idle stop	300	4.3~ 8.3		
	350	Below 3.0		

3. Dimensions

K	3.2 ~3.4	mm
KF	5.65~5.85	mm
MS	1.1 ~1.3	mm
BCS	—	mm

Control lever angle

α	21.0~29.0	deg
A	4.0~ 9.2	mm
β	41.0~51.0	deg
B	18.6~22.6	mm
Y	—	deg
C	—	mm

2-5 Solenoid Max.cut-in voltage : 8 V
Test voltage : 12~14 V

○W—CSD Adjustment

1) Timer stroke adjustment

1. Calculate the timer stroke from Fig. 2 according to the atmospheric temperature at the time of adjustment.
2. Adjust using timer stroke adjusting screw so that the timer stroke is as calculated in Step 1

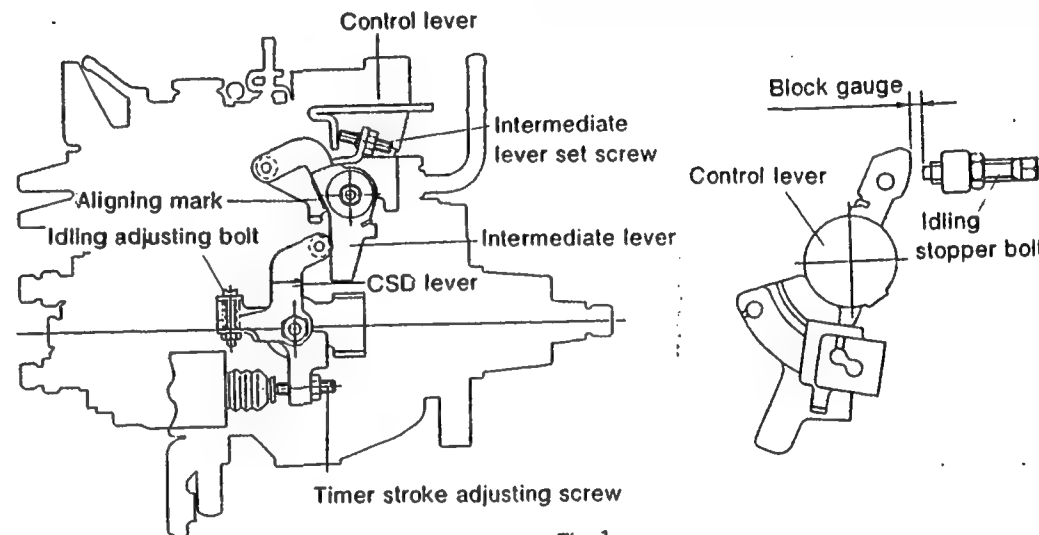

Fig. 1

2) Intermediate lever position adjustment

1. Insert a block gauge (thickness gauge) of 1.9 ± 0.05 mm thickness between the control lever and the idling stopper bolt.
2. Align the intermediate lever with the aligning mark.
3. Adjust the intermediate lever set screw so that the control lever and intermediate lever set screw are in contact, and then fix in position using the locknut.

3) CSD lever adjustment

1. Calculate block gauge dimension $l \pm 0.05$ mm from Fig. 2 according to the atmospheric temperature at the time of adjustment.
2. Insert the block gauge (thickness gauge) between the control lever and the idling stopper bolt.
3. Using the idling bolt, adjust so that the CSD lever roller and intermediate lever are in contact.

Notes:

1. The temperature of the wax must be below 30°C when adjusting.
2. When inserting a block gauge (thickness gauge) between the control lever and the idling stopper bolt, use the idling adjusting bolt to separate the CSD lever and intermediate lever so that no excessive force is exerted on them.

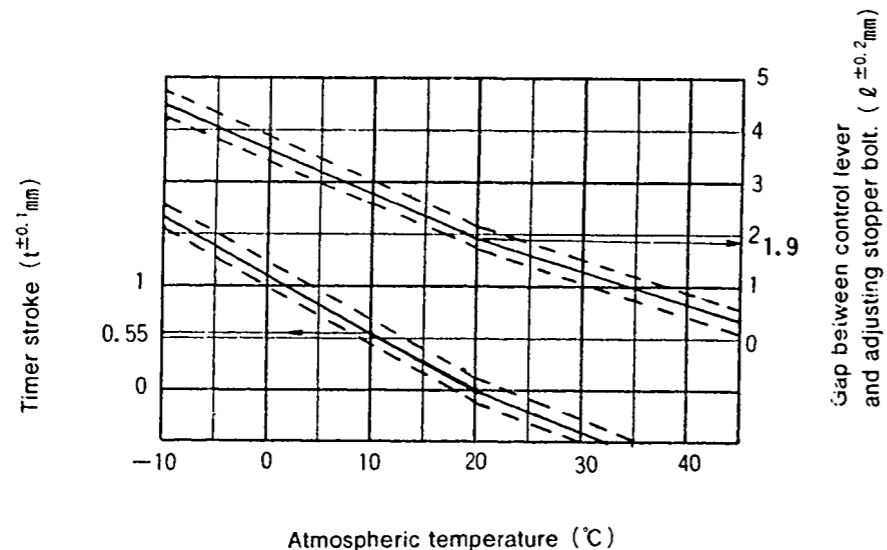

Fig. 2

Formula for calculating Fig. 2

Formula for calculating timer stroke:

When $-10 \leq \theta \leq 20$ $TA = -0.055\theta + 1.1$

When $20 \leq \theta \leq 40$ $TA = -0.0333\theta + 0.66$

Control lever and Idling Formula for calculating stopper bolt gap:

When $-10 \leq \theta \leq 20$ $l = -0.0867\theta + 3.63$

When $20 \leq \theta \leq 40$ $l = -0.075t + 3.4$

INJ. PUMP CALIBRATION DATA

TEST OIL:
ISO 4113 or
SAE J967d

Distributor-type

ENGINE MODEL : SD25

Injection pump No: 104640-4770 [NP-VE4/10F2100RNP396]

BOSCH No.9 460 610 142
DKKC No. 104740-4810
Date: 20.Nov.1986
Company: NISSAN DIESEL
No. 16700 37G03

104740-4810 2/3

Pump rotation : clockwise-viewed from drive side

For Test Condition see
Microfiche No.WP-210(N16)

Pre-stroke : 0.26~0.30 mm

1. Setting	Pump speed (rpm)	Settings	Charge air press(mmHg)	Difference in delivery(cc)
1-1 Timing device travel	1,000	1.5~ 1.9 (mm)		
1-2 Supply pump pressure	1,000	4.0~ 4.6 (kg/cm ²)		
1-3 Full load delivery without charge air pressure	1,000	39.9~40.9 (cc/1,000st)		3.0
Full load delivery with charge air pressure		(cc/1,000st)		
1-4 Idle speed regulation	300	4.3~ 8.3 (cc/1,000st)		2.0
1-5 Start	100	45.0~80.0 (cc/1,000st)		
1-6 Full-load speed regulation	2,350	11.7~17.7 (cc/1,000st)		
1-7				
1-8				

2. Test Specifications

2-1 Timing device	N = rpm	1,000	1,400	2,100
	mm	1.4~ 2.0	2.7~ 3.9	5.6~ 6.8
2-2 Supply pump	N = rpm	600	1,000	2,100
	kg/cm ²	3.1~ 3.7	4.0~ 4.6	6.6~ 7.2
2-3 Overflow delivery	N = rpm	1,000		
	cc/10s	8.0~52.0		

2-4 Fuel deliveries

Speed control lever	Pump speed (rpm)	Fuel delivery (cc/1,000st)	Charge air press(mmHg)	Difference in delivery
End stop	1,000	39.4~41.4		
	600	36.5~40.5		
	2,100	33.6~37.8		
	2,350	11.2~18.2		
	2,450	Below 5.0		
Switch OFF	300	0		
Idle stop	300	4.5~ 8.5		
	350	Below 3.0		

3. Dimensions

K	3.2 ~3.4	mm
KF	5.65~5.85	mm
MS	1.1 ~1.3	mm
BCS	—	mm

Control lever angle

α	21.0~29.0	deg
A	4.0~ 9.2	mm
β	37.0~47.0	deg
B	10.7~14.8	mm
γ	—	deg
C	—	mm

W-CSD Adjustment

1) Timer stroke adjustment

1. Calculate the timer stroke from Fig. 2 according to the atmospheric temperature at the time of adjustment.
2. Adjust using timer stroke adjusting screw so that the timer stroke is as calculated in Step 1.

Step 1.

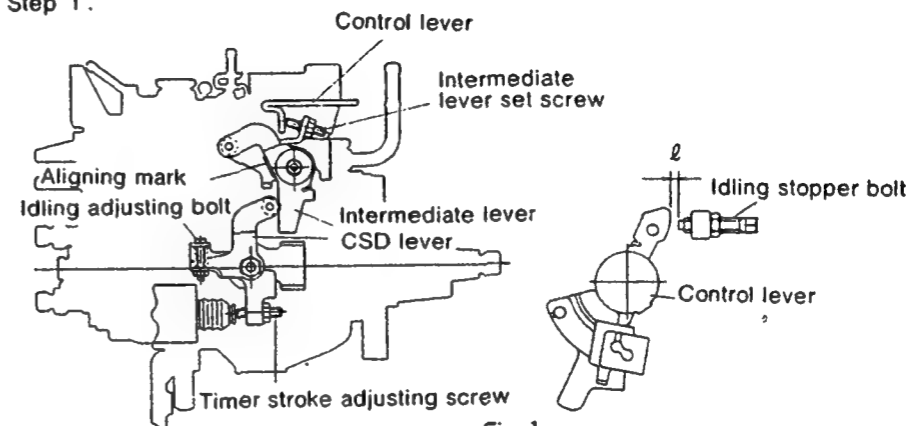

Fig 1.

Formula for calculating Fig. 2

Formula for calculating timer stroke:

$$\text{When } -10 \leq t (^{\circ}\text{C}) \leq 20 \quad T = -0.055t + 1.1$$

$$\text{When } 20 \leq t (^{\circ}\text{C}) \leq 40 \quad T = -0.0333t + 0.66$$

Formula for calculating control lever and idling stopper bolt gap:

$$\text{When } -10 \leq t (^{\circ}\text{C}) \leq 20 \quad \ell = -0.0867t + 3.63$$

$$\text{When } 20 \leq t (^{\circ}\text{C}) \leq 40 \quad \ell = -0.075t + 3.4$$

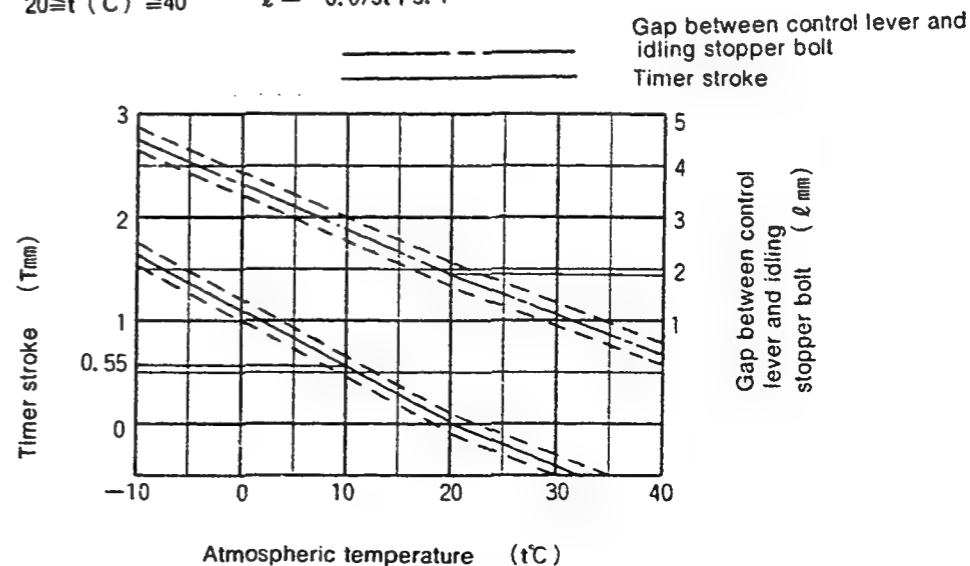

Fig 2.

DIESEL KIKI

DIESEL KIKI CO. LTD. 3-6-7 SHIBUYA, SHIBUYA-KU, TOKYO 150, JAPAN
Service Department Tel. (03) 400-1551 · Fax: (03) 499-4115

104740-4810 3/3

2) Intermediate lever position adjustment

1. Insert a block gauge (thickness gauge) of 1.9 ± 0.05 mm thickness between the control lever and the idling stopper bolt.
2. Align the intermediate lever with the aligning mark.
3. Adjust the intermediate lever set screw so that the control lever and intermediate lever set screw are in contact, and then fix in position using the locknut.

3) CSD lever adjustment

1. Calculate the block gauge dimension $l \pm 0.05$ mm from Fig. 2 according to the atmospheric temperature at the time of adjustment.
2. Insert the block gauge (thickness gauge) between the control lever and the idling stopper bolt.
3. Using the idling bolt, adjust so that the CSD lever roller and intermediate lever are in contact.

Notes :

1. The temperature of the wax must be below 30°C when adjusting.
2. When inserting a block gauge (thickness gauge) between the control lever (beacket) and the idling stopper bolt, use the idling adjusting bolt to separate the CSD lever and intermediate lever so that no excessive force is exerted on them.

INJ. PUMP CALIBRATION DATA

Distributor-type

TEST OIL:
I S O 4113 or
S A E J967d

ENGINE MODEL : RF

Injection pump No: 104648-0133(NP-VE4/8F2325RNP205)

BOSCH No.9 460 610 143
DKKC No. 104748-0133
Date : 20.Nov.1986 [0]
Company: MAZDA
No. RF01 13 800C

104748-0133 2/3

Pump rotation : clockwise-viewed from drive side
Pre-stroke : - mm

For Test Condition see
Microfiche No.WP-210(N16)

1. Setting	Pump speed (rpm)	Settings	Charge air press(mmHg)	Difference in delivery(cc)
1-1 Timing device travel	1,375	4.5~ 4.9 (mm)		
1-2 Supply pump pressure	1,375	4.4~ 5.0 (kg/cm ²)		
1-3 Full load delivery without charge air pressure	1,375	35.6~36.6 (cc/1,000st)		2.5
Full load delivery with charge air pressure		(cc/1,000st)		
1-4 Idle speed regulation	350	6.0~10.0 (cc/1,000st)		2.0
1-5 Start	100	Above 42 (cc/1,000st)		
1-6 Full-load speed regulation	2,500	19.1~23.1 (cc/1,000st)		
1-7 Load timer adjustment	1,375	4.1±0.2 (mm)		
1-8				

LOAD TIMER ADJUSTMENT

1) Adjustment

① Fix the control lever in the position satisfying the following conditions.

Boost Pressure : - mmHg
Pump Speed : 1375 rpm
Fuel Injection : 28.2±1 cc/1000st
Quantity

② With the control lever positioned as described in ① above, adjust the governor sleeve so that Timer Stroke conforms to the specified values (page 1/3).

2) Confirmation of Timer Characteristics

Fix the control lever in the position satisfying the following conditions, and confirm the Timer Stroke.

2. Test Specifications

2-1 Timing device	N = rpm	1,375	2,000	2,325	
	mm	4.4~ 5.0	7.4~ 8.6	9.1~10.3	
2-2 Supply pump	N = rpm	500	1,375	2,325	
	kg/cm ²	1.9~ 2.5	4.4~ 5.0	6.9~ 7.5	
2-3 Overflow delivery	N = rpm	1,375			
	cc/10s	46.3~90.3			
2-4 Fuel deliveries	Speed control lever	Pump speed (rpm)	Fuel delivery (cc/1,000st)	Charge air press(mmHg)	Difference in delivery
	End stop	1,375	35.1~37.1		
		500	27.5~31.5		
		2,325	29.7~33.7		
		2,500	18.1~24.1		
		2,750	Below 4.0		
	Switch OFF	350	0		
	Idle stop	350	6.0~10.0		
		450	Below 4.0		
2-5 Solenoid	Max.cut-in voltage : 8 V		Test voltage : 12~14 V		

3. Dimensions

K	3.2~3.4	mm
KF	5.7~5.9	mm
MS	1.4~1.6	mm
BCS	-	mm

Control lever angle

α	26.0~34.0	deg
A	4.0~ 9.5	mm
β	40.0~50.0	deg
B	12.5~15.8	mm
γ	-	deg
C	-	mm

Control lever position			Specified Values	
Pump speed (rpm)	Fuel Injection Quantity(cc/1000st)	Boost pressure (mmHg)	Timer stroke (mm)	Timer stroke reduction value (mm)
1,350	28.2±1.5	-	4.1±0.3	-
1,350	16.1±1.5	-	2.9±0.7	-

M-CSD Assembly and Adjustment

1) Fixing the M-CSD stopper

1. Fix the M-CSD assembly temporarily to the pump housing.
2. Turn the drive shaft at least two turns in the direction of pump rotation.
3. Turn the drive shaft slowly, and fix the drive shaft in a position where a load is applied (the point where the roller in the roller holder contacts the cam surface of the cam disc).
4. Move the CSD lever to the advance side.
5. Fix the CSD lever in the position where the ball pin at the tip of the shaft lightly contacts the roller holder (roller holder advance angle "0").
6. Adjust the stopper position so that the gap between the CSD lever and the stopper is 0.5 ± 2 mm.
7. After adjustment, tighten the M-CSD screw to the specified torque. $T=0.6-0.9 \text{ kg} \cdot \text{m}$

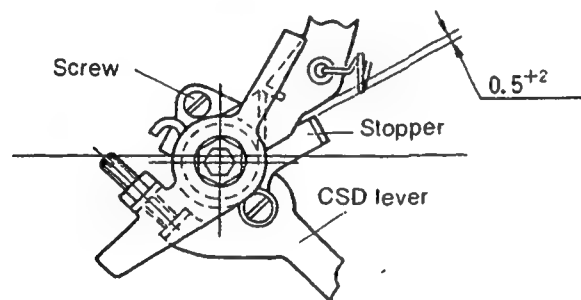

2) FICD screw adjustment

1. Move the CSD lever so that it contacts the stopper.
2. Insert a block gauge (thickness gauge) of 4.8 ± 1 mm thickness between the control lever and idling stopper bolt. (Position 7° from idle)
3. Adjust using the FICD screw so that the control lever and FICD screw are in contact.

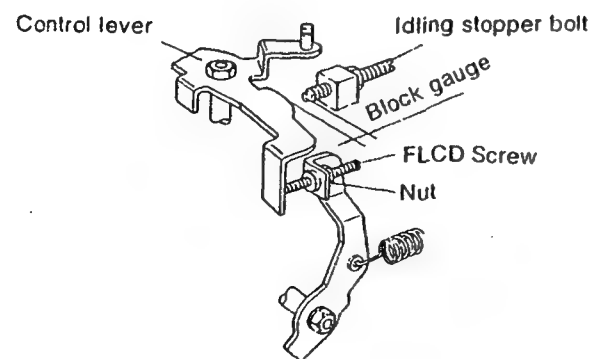

INJ. PUMP CALIBRATION DATA

Distributor-type

TEST OIL:
I S O 4113 or
S A E J967d

ENGINE MODEL : RF

Injection pump No: 104648-0134 [NP-VE4/8F2325RNP205]

BOSCH No. 9 460 610 188
DKKC No. 104748-0134
Date: 20 Nov. 1986
Company: MAZDA
No. RF01 13 800E

LOAD TIMER ADJUSTMENT

1) Adjustment

① Fix the control lever in the position satisfying the following conditions.

Boost Pressure : — mmHg
Pump Speed : 1375 rpm
Fuel Injection : 28.2±1 cc/1000st
Quantity

② With the control lever positioned as described in ① above, adjust the governor sleeve so that the Timer Stroke conforms to the specified values (page 1/4)

2) Confirmation of Timer Characteristics

Fix the control lever in the position satisfying the following conditions, and confirm the Timer Stroke.

Control lever position			Specified Values	
Pump speed (rpm)	Fuel Injection Quantity(cc/1000st)	Boost pressure (mmHg)	Timer stroke (mm)	Timer stroke reduction value (mm)
1,375	28.2±1.5	—	4.1±0.3	—
1,375	16.1±1.5	—	2.9±0.7	—

Pump rotation : clockwise-viewed from drive side
Pre-stroke : — mm

For Test Condition see
Microfiche No.WP-210(N16)

1. Setting	Pump speed (rpm)	Settings	Charge air press(mmHg)	Difference in delivery(cc)
1-1 Timing device travel	1,375	4.5~ 4.9 (mm)		
1-2 Supply pump pressure	1,375	4.4~ 5.0 (kg/cm ²)		
1-3 Full load delivery without charge air pressure	1,375	35.6~36.6 (cc/1,000st)		2.5
Full load delivery with charge air pressure		(cc/1,000st)		
1-4 Idle speed regulation	350	6.0~10.0 (cc/1,000st)		2.0
1-5 Start	100	Above 42.0 (cc/1,000st)		
1-6 Full-load speed regulation	2,500	19.1~23.1 (cc/1,000st)		
1-7 Load-timer Adjustment	1,375	3.9~ 4.3 (mm)		
1-8				

2. Test Specifications

2-1 Timing device	N = rpm mm	1,375 4.4~ 5.0	1,750 6.1~ 7.3	2,325 7.2~ 8.4	
2-2 Supply pump	N = rpm kg/cm ²	500 1.9~ 2.5	1,375 4.4~ 5.0	2,325 7.0~ 7.6	
2-3 Overflow delivery	N = rpm cc/10s	1,375 46.3~90.3			
2-4 Fuel deliveries	Speed control lever	Pump speed (rpm)	Fuel delivery (cc/1,000st)	Charge air press(mmHg)	Difference in delivery
End stop		1,375	35.1~37.1		
		500	28.0~32.0		
		2,325	30.2~34.2		
		2,500	18.1~24.1		
		2,750	Below 4.0		
Switch OFF		350	0		
Idle stop		350	6.0~10.0		
		450	Below 4.0		
2-5 Solenoid		Max.cut-in voltage : 8 V Test voltage : 12~14 V			

3. Dimensions

K	3.2~3.4	mm
KF	5.7~5.9	mm
MS	1.4~1.6	mm
BCS	—	mm

Control lever angle

α	26.0~34.0	deg
A	4.0~ 9.5	mm
β	40.0~50.0	deg
B	12.5~15.8	mm
Y	—	deg
C	—	mm

■ M-CSD Assembly and Adjustment

1) Fixing the M-CSD stopper

1. Fix the M-CSD assembly temporarily to the pump housing.
2. Turn the drive shaft at least two turns in the direction of pump rotation.
3. Turn the drive shaft slowly, and fix the drive shaft in a position where a load is applied (the point where the roller in the roller holder contacts the cam surface of the cam disc).
4. Move the CSD lever to the advance side.
5. Fix the CSD lever in the position where the ball pin at the tip of the shaft lightly contacts the roller holder (roller holder advance angle "0").
6. Adjust the stopper position so that the gap between the CSD lever and the stopper is 0.5 ± 2 mm.
7. After adjustment, tighten the M-CSD screw to the specified torque (T).
 $T = 0.6 - 0.9 \text{ kg} \cdot \text{m}$

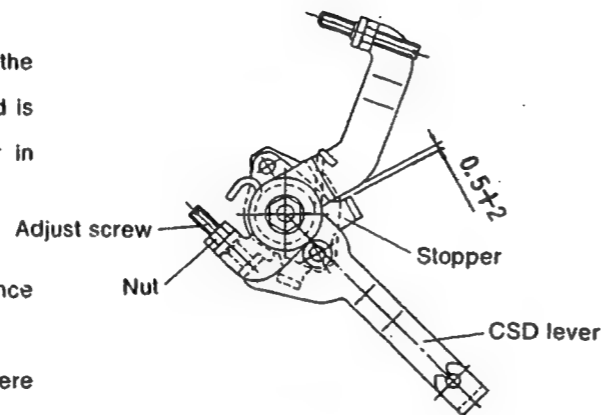

2) FICD screw adjustment

1. Move the CSD lever so that it contacts the stopper.
2. Insert a block gauge (thickness gauge) of 4.8 ± 0.1 mm thickness between the control lever and idling stopper bolt. (to position the control lever 7° from the idling position).
3. Adjust the FICD screw so that the control lever and the FICD screw are in contact.

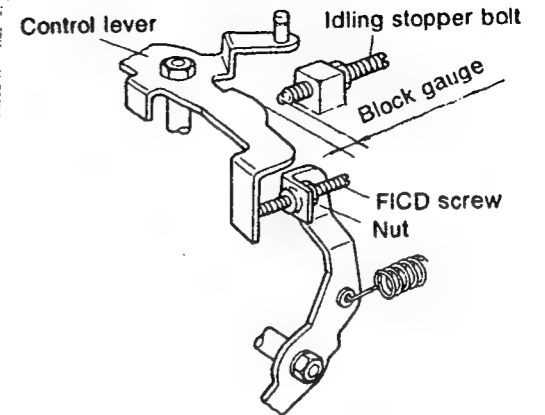

INJ. PUMP CALIBRATION DATA

Distributor-type

TEST OIL:
ISO 4113 or
SAE J967d

ENGINE MODEL : RF

BOSCH No.9 460 610 189
DKKC No. 104748-0144
Date: 20.Nov.1986
Company: MAZDA
No. RF02 13 800E

104748-0144 2/5

Injection pump No: 104648-0144 (NP-VE4/8F2325RNP206)

Pump rotation : clockwise-viewed from drive side

For Test Condition see
Microfiche No.WP-210(N16)

Pre-stroke : - mm

1. Setting	Pump speed (rpm)	Settings	Charge air press(mmHg)	Difference in delivery(cc)
1-1 Timing device travel	1,375	4.5~ 4.9 (mm)		
1-2 Supply pump pressure	1,375	4.4~ 5.0 (kg/cm ²)		
1-3 Full load delivery without charge air pressure	1,375	35.6~36.6 (cc/1,000st)		2.5
Full load delivery with charge air pressure		(cc/1,000st)		
1-4 Idle speed regulation	350	6.0~10.0 (cc/1,000st)		2.0
1-5 Start	100	Above 42.0 (cc/1,000st)		
1-6 Full-load speed regulation	2,500	19.1~23.1 (cc/1,000st)		
1-7 Load-timer Adjustment	1,375	3.9~ 4.3 (mm)		
1-8				

2. Test Specifications

2-1 Timing device	N = rpm	1,375	1,750	2,325
	mm	4.4~ 5.0	6.1~ 7.3	7.2~ 8.4
2-2 Supply pump	N = rpm	500	1,375	2,325
	kg/cm ²	1.9~ 2.5	4.4~ 5.0	7.0~ 7.6
2-3 Overflow delivery	N = rpm	1,375		
	cc/10s	46.3~90.3		
2-4 Fuel deliveries				
Speed control lever	Pump speed (rpm)	Fuel delivery (cc/1,000st)	Charge air press(mmHg)	Difference in delivery
End stop	1,375	35.1~37.1		
	500	28.0~32.0		
	2,325	30.2~34.2		
	2,500	18.1~24.1		
	2,750	Below 4.0		
Switch OFF	350	0		
Idle stop	350	6.0~10.0		
	450	Below 4.0		
2-5 Solenoid	Max.cut-in voltage : 8 V Test voltage : 12~14 V			

3. Dimensions

K	3.2~3.4 mm
KF	5.7~5.9 mm
MS	1.4~1.6 mm
BCS	- mm
Control lever angle	
α	26.0~34.0 deg
A	4.0~ 9.5 mm
β	40.0~50.0 deg
B	12.5~15.8 mm
Y	- deg
C	- mm

LOAD TIMER ADJUSTMENT

1) Adjustment

① Fix the control lever in the position satisfying the following conditions.

Boost Pressure : - mmHg

Pump Speed : 1375 rpm

Fuel Injection : 28.2±1 cc/1000st
Quantity

② With the control lever positioned as described in ① above, adjust the governor sleeve so that the Timer Stroke conforms to the specified values (page 1/5)

2) Confirmation of Timer Characteristics

Fix the control lever in the position satisfying the following conditions, and confirm the Timer Stroke.

Control lever position			Specified Values	
Pump speed (rpm)	Fuel Injection Quantity(cc/1000st)	Boost pressure (mmHg)	Timer stroke (mm)	Timer stroke reduction value (mm)
1375	28.2±1.5	-	4.1±0.3	-
1375	16.1±1.5	-	2.9±0.7	-



DIESEL KIKI

DIESEL KIKI CO. LTD. 3-6-7 SHIBUYA, SHIBUYA-KU, TOKYO 150, JAPAN
Service Department Tel. (03) 400-1551 Fax: (03) 489-4115

■ M-CSD Assembly and Adjustment

1) Fixing the M-CSD stopper

1. Fix the M-CSD assembly temporarily to the pump housing.
2. Turn the drive shaft at least two turns in the direction of pump rotation.
3. Turn the drive shaft slowly, and fix the drive shaft in a position where a load is applied (the point where the roller in the roller holder contacts the cam surface of the cam disc).
4. Move the CSD lever to the advance side.
5. Fix the CSD lever in the position where the ball pin at the tip of the shaft lightly contacts the roller holder (roller holder advance angle "0").
6. Adjust using the adjusting screw so that the gap between the CSD lever and the stopper is 0.5 ± 2 mm.
7. After adjustment, tighten the M-CSD screw to the specified torque.
 $T = 0.6 - 0.9 \text{ kg} \cdot \text{m}$

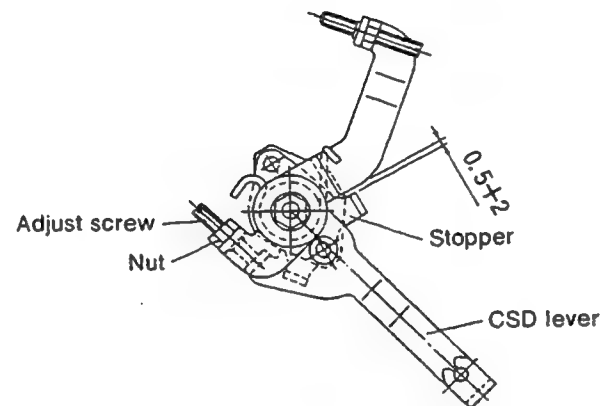

2) FICD screw adjustment

1. Move the CSD lever so that it contacts the stopper.
2. Insert a block gauge (thickness gauge) of 4.8 ± 0.1 mm thickness between the control lever and idling stopper bolt.
3. Adjust using the FICD screw so that the control lever and FICD screw are in contact.

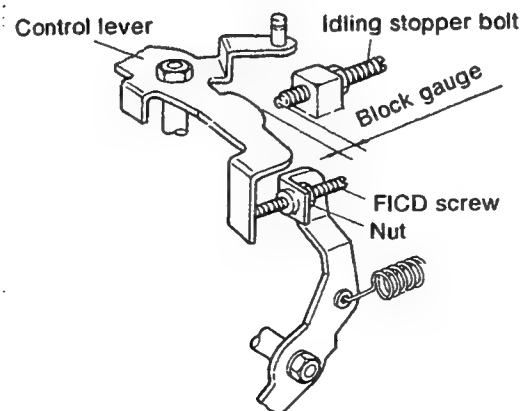

■ Microswitch Adjustment

1. Fix the control lever in a position where the gap between the control lever and idling stopper bolt is 8.5 ± 1 mm (control lever angle: 12.5°).
2. Adjust using the adjusting screw so that the microswitch comes ON.

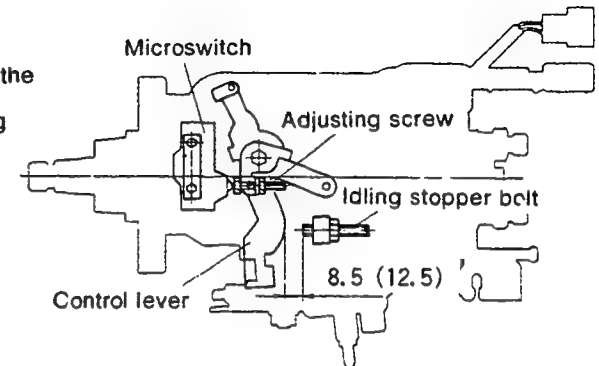

■ V-FICD Adjustment

1) V-FICD installation position adjustment

1. Hold the control lever in the idling position.
2. Adjust the position of the actuator mounting bracket so that the gap between the control lever roller and the actuator hook is 2 ± 1 mm.

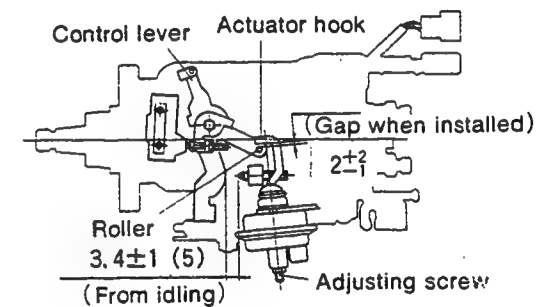

2) V-FICD stroke adjustment

1. Move the V-FICD through its full stroke.
2. Adjust using the adjusting screw so that the gap between the control lever and the idling stopper bolt is 3.4 ± 1 mm (control lever angle: 5°).

(From idling)

104648-0144 5/5

■ FICD Mounting Position Adjustment

1. Adjust the position of the bracket so that the gap between the control lever and the FICD bracket exceeds 3 mm.

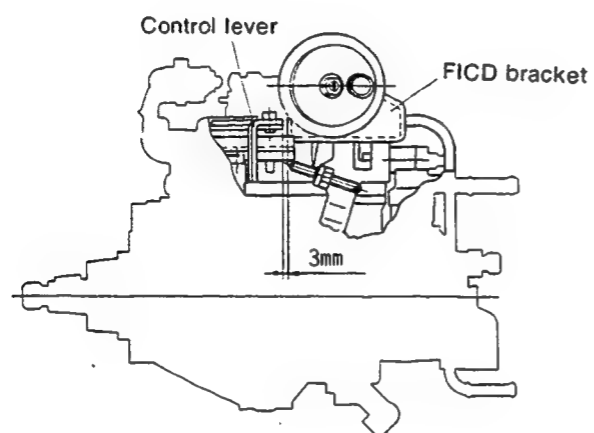

INJ. PUMP CALIBRATION DATA

TEST OIL:
I S O 4113 or
S A E J967d

Distributor—type

ENGINE MODEL : R2

BOSCH No.9 460 610 144

DKKC No. 104748—0152

Date : 20.Nov.1986

Company : MAZDA

No. R201 13 800B

104748—0152 2/3

Injection pump No: 104648—0152 [NP—VE4/8F2125RNP207]

Pump rotation : clockwise-viewed from drive side

For Test Condition see
Microfiche No.WP-210(N16)

Pre—stroke : — mm

1. Setting	Pump speed (rpm)	Settings	Charge air press(mmHg)	Difference in delivery(cc)
1-1 Timing device travel	1,250	3.7~ 4.1 (mm)		
1-2 Supply pump pressure	1,250	4.9~ 5.5 (kg/cm ²)		
1-3 Full load delivery without charge air pressure	1,500	38.2~39.2 (cc/1,000st)		2.5
Full load delivery with charge air pressure		(cc/1,000st)		
1-4 Idle speed regulation	350	6.0~10.0 (cc/1,000st)		2.0
1-5 Start	100	Above 42 (cc/1,000st)		
1-6 Full-load speed regulation	2,400	11.1~15.1 (cc/1,000st)		
1-7 Load timer adjustment	1,250	3.1±0.2 (mm)		
1-8				

2. Test Specifications

2-1 Timing device	N = rpm mm	1,250 3.6~ 4.2	1,500 4.6~ 5.8	2,125 8.6~ 9.4
2-2 Supply pump	N = rpm kg/cm ²	500 2.7~ 3.3	1,250 4.9~ 5.5	2,125 7.3~ 7.9
2-3 Overflow delivery	N = rpm cc/10s	1,250 49.7~93.7		

Speed control lever	Pump speed (rpm)	Fuel delivery (cc/1,000st)	Charge air press(mmHg)	Difference in delivery
End stop	1,500	37.7~39.7		
	500	30.7~34.7		
	2,125	32.0~36.0		
	2,400	10.1~16.1		
	2,550	Below 4.0		
Switch OFF	350	0		
Idle stop	350	6.0~10.0		

3. Dimensions

K	3.2~3.4 mm
KF	5.7~5.9 mm
MS	1.4~1.6 mm
BCS	— mm

Control lever angle

α	26.0~34.0 deg
A	4.0~ 9.5 mm
β	40.0~50.0 deg
B	12.5~15.8 mm
γ	— deg
C	— mm

2-5 Max.cut-in voltage : 8 V
Solenoid Test voltage : 12~14 V

LOAD TIMER ADJUSTMENT

1) Adjustment

① Fix the control lever in the position satisfying the following conditions.

Boost Pressure : — mmHg

Pump Speed : 1250 rpm

Fuel Injection : 28.2±1 cc/1000st

Quantity

② With the control lever positioned as described in ① above, adjust the governor sleeve so that

Timer Stroke conforms to the specified values (page 1 / 3) .

2) Confirmation of Timer Characteristics

Fix the control lever in the position satisfying the following conditions, and confirm the

Timer Stroke.

Control lever position			Specified Values	
Pump speed (rpm)	Fuel Injection Quantity(cc/1000st)	Boost pressure (mmHg)	Timer stroke (mm)	Timer stroke reduction value (mm)
1,250	28.2±1.5	—	3.1±0.3	—
1,250	18.1±1.5	—	1.9±0.7	—

M-CSD Assembly and Adjustment

1) Fixing the M-CSD stopper

1. Fix the M-CSD assembly temporarily to the pump housing.
2. Turn the drive shaft at least two turns in the direction of pump rotation.
3. Turn the drive shaft slowly, and fix the drive shaft in a position where a load is applied (the point where the roller in the roller holder contacts the cam surface of the cam disc).
4. Move the CSD lever to the advance side.
5. Fix the CSD lever in the position where the ball pin at the tip of the shaft lightly contacts the roller holder (roller holder advance angle "0").
6. Adjust the stopper position so that the gap between the CSD lever and the stopper is 0.5 ± 2 mm.
7. After adjustment, tighten the M-CSD screw to the specified torque. $T=0.6-0.9 \text{ kg} \cdot \text{m}$

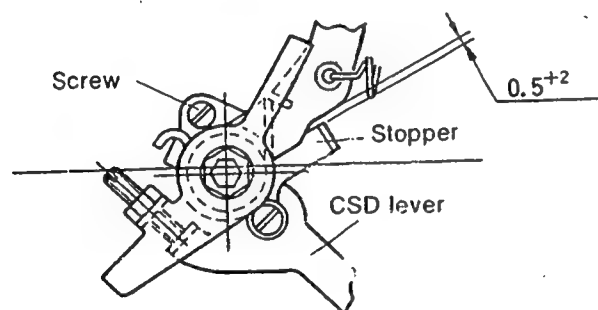

2) FICD screw adjustment

1. Move the CSD lever so that it contacts the stopper.
2. Insert a block gauge (thickness gauge) of 4.8 ± 1 mm thickness between the control lever and idling stopper bolt. (Position 7° from idle)
3. Adjust using the FICD screw so that the control lever and FICD screw are in contact.

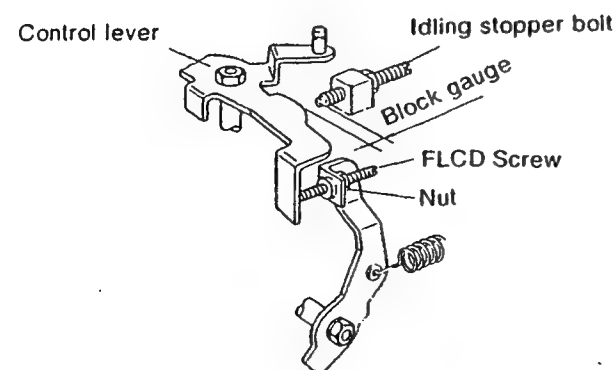

INJ. PUMP CALIBRATION DATA

Distributor-type

TEST OIL:
I S O 4113 or
S A E J967d

ENGINE MODEL : R2

BOSCH No.9 460 610 190
DKKC No. 104748-0153
Date : 20.Nov.1986
Company : MAZDA
No. R201 13 800D

Injection pump No: 104648-0153 (NP-VE4/8F2125RNP207)

Pump rotation : clockwise-viewed from drive side

For Test Condition see
Microfiche No.WP-210(N16)

Pre-stroke : - mm

1. Setting	Pump speed (rpm)	Settings	Charge air press(mmHg)	Difference in delivery(cc)
1-1 Timing device travel	1,250	3.3~ 3.7 (mm)		
1-2 Supply pump pressure	1,250	4.9~ 5.5 (kg/cm ²)		
1-3 Full load delivery without charge air pressure	1,500	38.2~39.2 (cc/1,000st)		2.5
Full load delivery with charge air pressure		(cc/1,000st)		
1-4 Idle speed regulation	350	6.0~10.0 (cc/1,000st)		2.0
1-5 Start	100	Above 42.0 (cc/1,000st)		
1-6 Full-load speed regulation	2,400	11.1~15.1 (cc/1,000st)		
1-7 Load-timer adjustment	1,250	2.7± 0.2 (mm)		
1-8				

2. Test Specifications

2-1 Timing device	N = rpm mm	1,250 3.2~ 3.8	1,500 4.1~ 5.3	2,125 7.0~ 8.2	
2-2 Supply pump	N = rpm kg/cm ²	500 2.7~ 3.3	1,250 4.9~ 5.5	2,125 7.3~ 7.9	
2-3 Overflow delivery	N = rpm cc/10s	1,250 49.7~93.7			
2-4 Fuel deliveries	Speed control lever	Pump speed (rpm)	Fuel delivery (cc/1,000st)	Charge air press(mmHg)	Difference in delivery
	End stop	1,500	37.7~39.7		
		500	30.7~34.7		
		2,125	32.0~36.0		
		2,400	10.1~16.1		
		2,550	Below 4.0		
	Switch OFF	350	0		
	Idle stop	350	6.0~10.0		
2-5 Solenoid		Max.cut-in voltage : 8 V Test voltage : 12~14 V			

3. Dimensions

K	3.2~3.4	mm
KF	5.7~5.9	mm
MS	1.4~1.6	mm
BCS	-	mm
Control lever angle		
α	28.0~32.0	deg
A	5.4~8.2	mm
β	40.0~50.0	deg
B	12.5~15.8	mm
γ	-	deg
C	-	mm

LOAD TIMER ADJUSTMENT

1) Adjustment

① Fix the control lever in the position satisfying the following conditions.

Boost Pressure : - mmHg
Pump Speed : 1250 rpm
Fuel Injection : 28.2±1 cc/1000st
Quantity

② With the control lever positioned as described in ① above, adjust the governor sleeve so that the Timer Stroke conforms to the specified values (page 1/4)

2) Confirmation of Timer Characteristics

Fix the control lever in the position satisfying the following conditions, and confirm the Timer Stroke.

Control lever position			Specified Values	
Pump speed (rpm)	Fuel Injection Quantity(cc/1000st)	Boost pressure (mmHg)	Timer stroke (mm)	Timer stroke reduction value (mm)
1250	28.2±1.5	-	2.7±0.3	-
1250	18.1±1.5	-	1.5±0.7	-

■ M-CSD Assembly and Adjustment

1) Fixing the M-CSD stopper

1. Fix the M-CSD assembly temporarily to the pump housing.
2. Turn the drive shaft at least two turns in the direction of pump rotation.
3. Turn the drive shaft slowly, and fix the drive shaft in a position where a load is applied (the point where the roller in the roller holder contacts the cam surface of the cam disc).
4. Move the CSD lever to the advance side.
5. Fix the CSD lever in the position where the ball pin at the tip of the shaft lightly contacts the roller holder (roller holder advance angle "0").
6. Adjust the adjusting screw so that the gap between the CSD lever and the stopper is $+ \text{mm}$.
7. After adjustment, tighten the M-CSD screw to the specified torque (T).

$$T = 0.6 \sim 0.9 \text{ kg} \cdot \text{m}$$

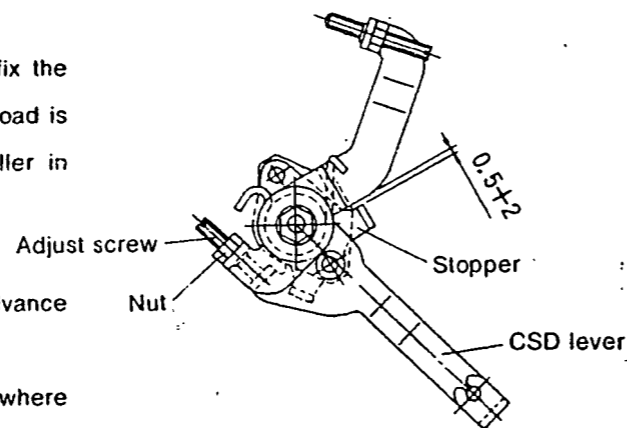

2) FICD screw adjustment

1. Move the CSD lever so that it contacts the stopper.
2. Insert a block gauge (thickness gauge) of 4.8 ± 1 mm thickness between the control lever and idling stopper bolt. (to position the control lever 7° from the idling position).
3. Adjust the FICD screw so that the control lever and the FICD screw are in contact.

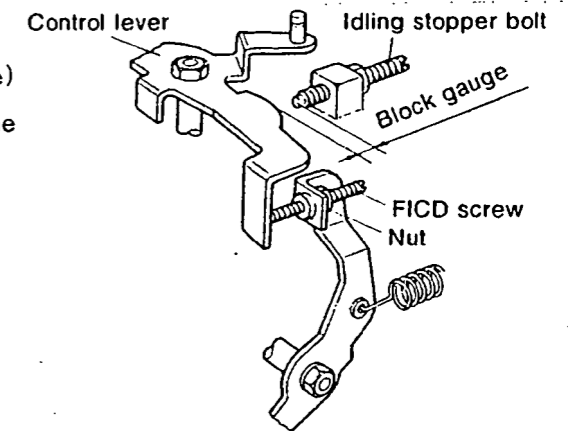

INJ. PUMP CALIBRATION DATA

TEST OIL:
I S O 4113 or
S A E J967J

Distributor-type

ENGINE MODEL : R2

BOSCH No.9 460 610 145 1/4
DKKC No. 104748-0162
Date : 20.Nov.1986
Company : MAZDA
No. R202 13 800B

104748-0162 2/4

Injection pump No: 104648-0162 (NP-VE4/8F2125RNP208)

Pump rotation : clockwise-viewed from drive side

For Test Condition see
Microfiche No.WP-210(N16)

Pre-stroke : - mm

1. Setting	Pump speed (rpm)	Settings	Charge air press(mmHg)	Difference in delivery(cc)
1-1 Timing device travel	1,250	3.7~ 4.1 (mm)		
1-2 Supply pump pressure	1,250	4.9~ 5.5 (kg/cm ²)		
1-3 Full load delivery without charge air pressure	1,500	38.2~39.2 (cc/1,000st)		2.5
Full load delivery with charge air pressure		(cc/1,000st)		
1-4 Idle speed regulation	350	6.0~10.0 (cc/1,000st)		2.0
1-5 Start	100	Above 42 (cc/1,000st)		
1-6 Full-load speed regulation	2,400	11.1~15.1 (cc/1,000st)		
1-7 Load-timer adjustment	1,250	3.1±0.2 (mm)		
1-8				

2. Test Specifications

2-1 Timing device	N = rpm	1,250	1,500	2,125
	mm	3.6~ 4.2	4.6~ 5.8	8.2~ 9.4
2-2 Supply pump	N = rpm	500	1,250	2,125
	kg/cm ²	2.7~ 3.3	4.9~ 5.5	7.3~ 7.9
2-3 Overflow delivery	N = rpm	1,250		
	cc/10s	49.7~93.7		

2-4 Fuel deliveries

Speed control lever	Pump speed (rpm)	Fuel delivery (cc/1,000st)	Charge air press(mmHg)	Difference in delivery
End stop	1,500	37.7~39.7		
	500	30.7~34.7		
	2,125	32.0~36.0		
	2,400	10.1~16.1		
	2,550	Below 4.0		
Switch OFF	350	0		
Idle stop	350	6.0~10.0		

3. Dimensions

K	3.2~3.4	mm
KF	5.7~5.9	mm
MS	1.4~1.6	mm
BCS	-	mm

Control lever angle

α	26.0~34.0	deg
A	4.0~ 9.5	mm
β	40.0~50.0	deg
B	12.5~15.8	mm
Y	-	deg
C	-	mm

2-5 Solenoid Max.cut-in voltage : 8 V
Test voltage : 12~14 V

LOAD TIMER ADJUSTMENT

1) Adjustment

① Fix the control lever in the position satisfying the following conditions.

Boost Pressure : - mmHg
Pump Speed : 1250 rpm
Fuel Injection : 28.2±1 cc/1000st
Quantity

② With the control lever positioned as described in ① above, adjust the governor sleeve so that

Timer Stroke conforms to the specified values (page 1 / 4) .

2) Confirmation of Timer Characteristics

Fix the control lever in the position satisfying the following conditions, and confirm the Timer Stroke.

Control lever position			Specified Values	
Pump speed (rpm)	Fuel Injection Quantity(cc/1000st)	Boost pressure (mmHg)	Timer stroke (mm)	Timer stroke reduction value (mm)
1,250	28.2±1.5	-	3.1±0.3	-
1,250	18.1±1.5	-	1.9±0.7	-

M-CSD Assembly and Adjustment

1) Fixing the M-CSD stopper

1. Fix the M-CSD assembly temporarily to the pump housing.
2. Turn the drive shaft at least two turns in the direction of pump rotation.
3. Turn the drive shaft slowly, and fix the drive shaft in a position where a load is applied (the point where the roller in the roller holder contacts the cam surface of the cam disc) .
4. Move the CSD lever to the advance side.
5. Fix the CSD lever in the position where the ball pin at the tip of the shaft lightly contacts the roller holder (roller holder advance angle "0") .
6. Adjust the stopper position so that the gap between the CSD lever and the stopper is 0.5+2 mm.
7. After adjustment, tighten the M-CSD screw to the specified torque. T=0.6-0.9kg · m

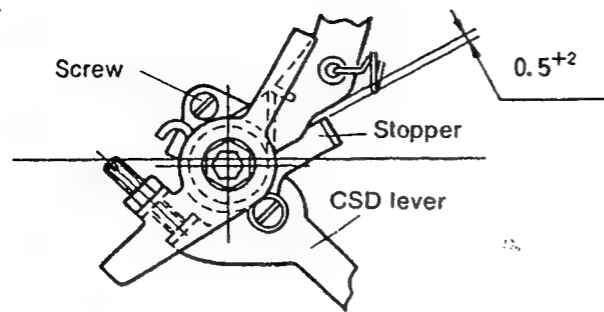

2) FICD screw adjustment

1. Move the CSD lever so that it contacts the stopper.
2. Insert a block gauge (thickness gauge) of 4.8 ± 1 mm thickness between the control lever and idling stopper bolt. (Position 7° from idle)
3. Adjust using the FICD screw so that the control lever and FICD screw are in contact.

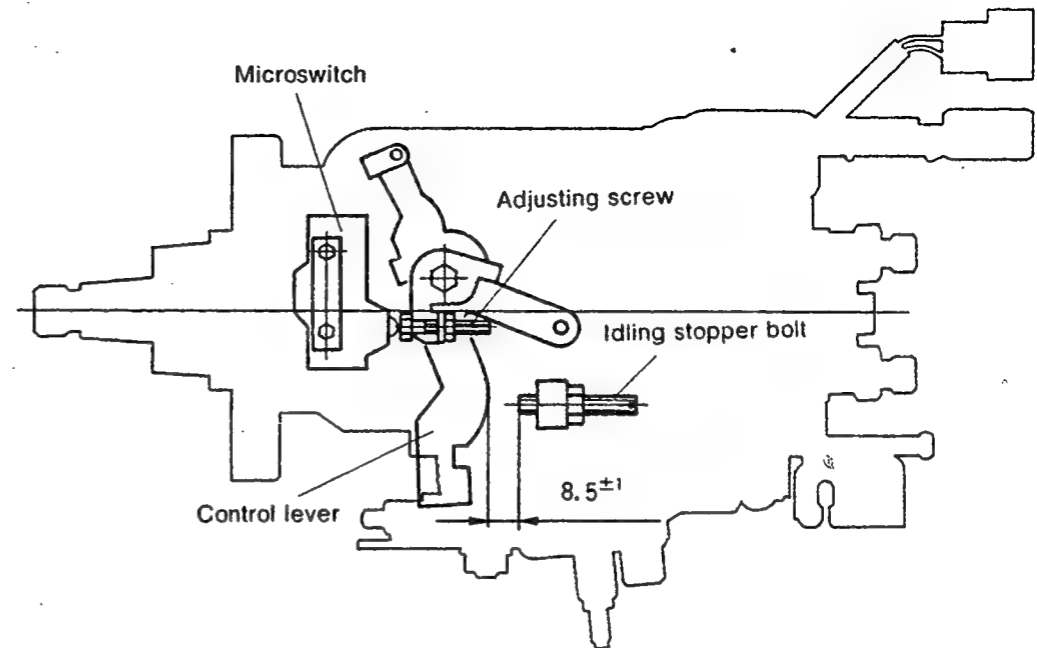
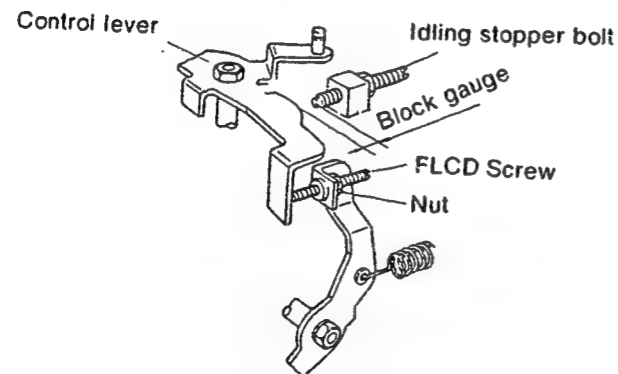

○ V-FICD Adjustment

1) V-FICD installation position adjustment

1. Hold the control lever in the idling position.
2. Adjust the position of the actuator mounting bracket so that the gap between the control lever roller and the actuator hook is 2 ± 2 mm.

2) V-FICD stroke adjustment

1. Move the V-FICD through its full stroke.
2. Adjust using the adjusting screw so that the gap between the control lever and the idling stopper bolt is 3.4 ± 1 mm (control lever angle: 5°).

Microswitch Adjustment

1. Fix the control lever in a position where the gap between the control lever and idling stopper bolt is 8.5 ± 1 mm (control lever angle : 12.5°)
2. Adjust using the adjusting screw so that the microswitch comes ON.

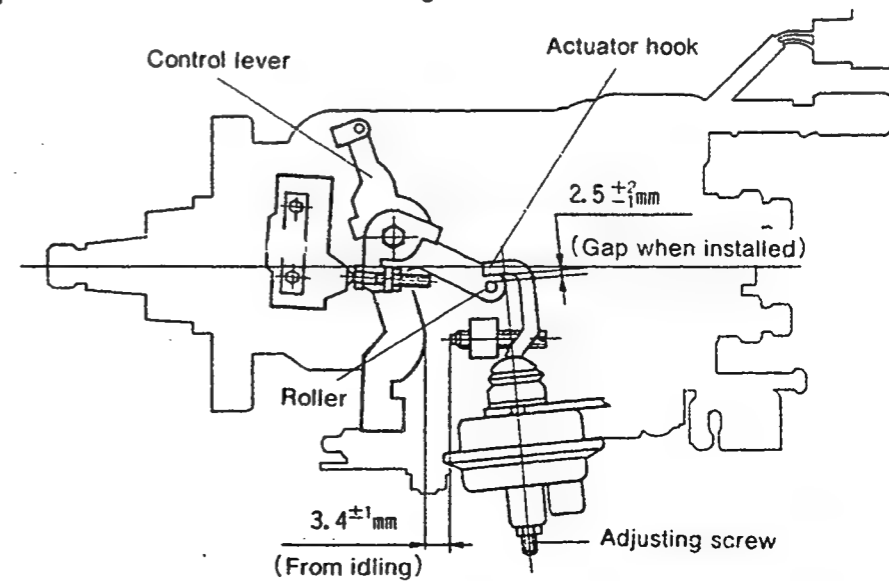

INJ. PUMP CALIBRATION DATA

TEST OIL:
ISO 4113 or
SAE J967d

Distributor—type

ENGINE MODEL : RF

BOSCH No.9 460 610 126

DKKC No. 104748-0173

Date : 20.Nov.1986

Company : MAZDA

No. RF11 13 800C

104748-0173 2/5

Injection pump No: 104648-0173 (NP-VE4/8F2325LNP216)

Pump rotation : Counter clockwise-viewed from drive side

For Test Condition see
Microfiche No.WP-210(N16)

Pre-stroke : - mm

1. Setting	Pump speed (rpm)	Settings	Charge air press(mmHg)	Difference in delivery(cc)
1-1 Timing device travel	1,375	4.0~ 4.4 (mm)		
1-2 Supply pump pressure	1,375	4.4~ 5.0 (kg/cm ²)		
1-3 Full load delivery without charge air pressure	1,375	35.4~36.4 (cc/1,000st)		2.5
Full load delivery with charge air pressure		(cc/1,000st)		
1-4 Idle speed regulation	410	7.0~ 9.0 (cc/1,000st)		2.0
1-5 Start	100	Above 42.0 (cc/1,000st)		
1-6 Full-load speed regulation	2,600	10.8~14.8 (cc/1,000st)		
1-7 Load timer adjustment	1,375	3.6±0.2 (mm)		
1-8				

2. Test Specifications

2-1 Timing device	N = rpm mm	1,375 3.9~ 4.5	1,800 6.1~ 7.3	2,325 7.2~ 8.4	
2-2 Supply pump	N = rpm kg/cm ²	600 2.2~ 2.8	1,375 4.4~ 5.0	2,325 6.9~ 7.5	
2-3 Overflow delivery	N = rpm cc/10s	1,375 46.3~90.3			
2-4 Fuel deliveries	Speed control lever	Pump speed (rpm)	Fuel delivery (cc/1,000st)	Charge air press(mmHg)	Difference in delivery
End stop		2,700	Below 6.0		
		2,600	9.8~15.8		
		2,325	30.2~34.2		
		1,375	34.9~36.9		
		600	29.0~33.0		
Switch OFF		410	0		
Idle stop		410	6.0~10.0		
2-5 Solenoid		Max.cut-in voltage : 8 V Test voltage : 12~14 V			

3. Dimensions

K	3.2 ~3.4	mm
KF	5.7 ~5.9	mm
MS	1.4 ~1.6	mm
BCS	—	mm

Control lever angle

α	16.0~24.0	deg
A	5.7~10.9	mm
β	40.0~50.0	deg
B	12.7~16.0	mm
γ	—	deg
C	—	mm

LOAD TIMER ADJUSTMENT

1) Adjustment

① Fix the control lever in the position satisfying the following conditions.

Boost Pressure : — mmHg
Pump Speed : 1375 rpm
Fuel Injection : 28.2±1 cc/1000st
Quantity

② With the control lever positioned as described in ① above, adjust the governor sleeve so that

Timer Stroke conforms to the specified values (page 1/5).

2) Confirmation of Timer Characteristics

Fix the control lever in the position satisfying the following conditions, and confirm the Timer Stroke.

Control lever position			Specified Values	
Pump speed (rpm)	Fuel Injection Quantity(cc/1000st)	Boost pressure (mmHg)	Timer stroke (mm)	Timer stroke reduction value (mm)
1,375	28.2±1.5	—	3.6±0.3	—
1,375	16.1±1.5	—	2.4±0.7	—

Side Link Lever Adjustment

1) Side link lever adjustment

1. Fix the control lever in the idling position.
2. Check that side link levers (1) and (2) contact the stoppers. (Portion A)

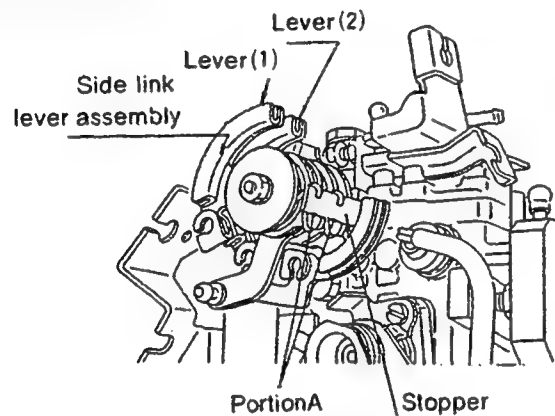

3. If control lever (4) and lever (3) are not connected by rod (5), connect them.
4. After connecting rod (5), adjust the length of rod (5) so that the gap at the hook of lever (3) and levers (1) and (2) is 0.5 ± 0.1 mm.

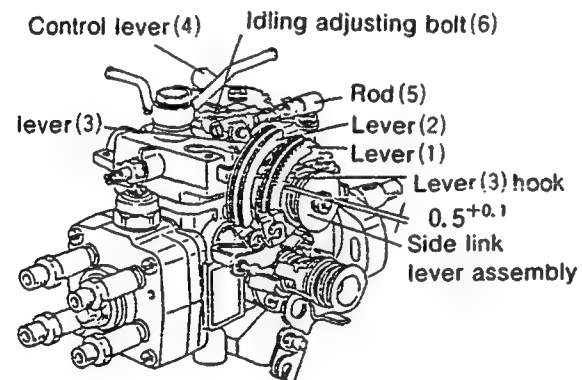

2) M-CSD adjustment

1. Loosen M-CSD lock screw (7).
2. Turn the drive shaft two or three turns and set the measuring device at 0.
3. Move the CSD lever gently in the direction of the arrow (advance direction).
4. Fix the CSD lever in a position where the CSD lever shaft ball pin contacts the roller holder. (Move gently, and hold the CSD lever in the position where the resistance changes.)
5. Check that the measuring device is at the 0 point.
6. Adjust the position of the stopper so that the gap between CSD lever (8) and stopper (9) is 0.5 ± 2 mm, and then fix in position using screw (7).
7. Turn the drive shaft two or three turns, check the position of the measuring device 0 point, and then recheck the gap between CSD lever (8) and stopper (9).

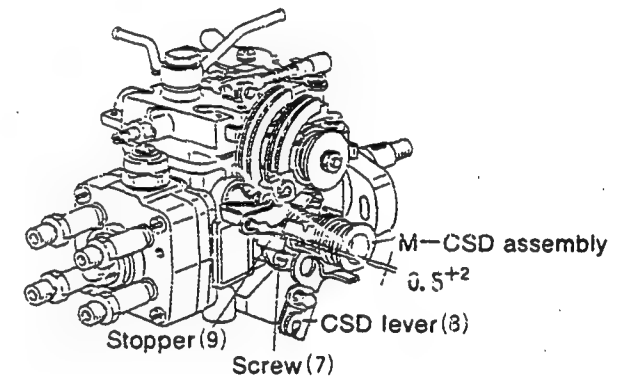
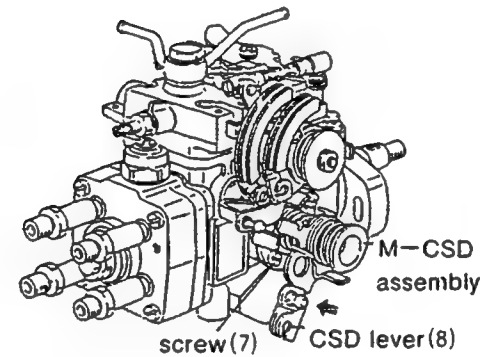

3) Fixing the CSD lever and side link lever connecting rod

1. Connect the side link lever assembly and CSD lever using rod (10).
2. Move the CSD lever through its full stroke (in the direction the arrow).
3. Adjust the length of rod (10) so that the gap between control lever (4) and idling adjusting bolt (6) is 8.5 mm, and then fix in this position.

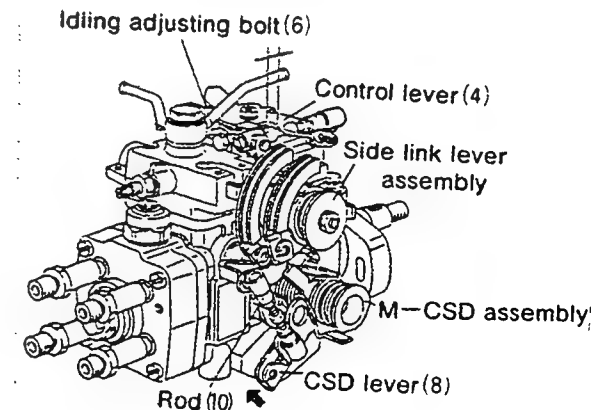

104748-0173 5/5

4) Fixing the engine installation bracket

1. Fix the bracket temporarily to the pump.
2. Move the bracket in the direction of the arrow until the clearance is 0.
3. Fix the bracket in position using the bolts.

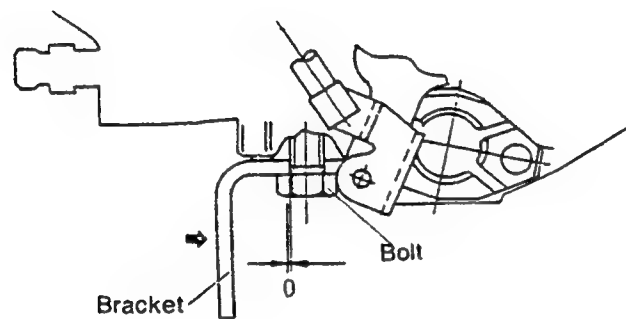

INJ. PUMP CALIBRATION DATA

1/3

TEST OIL:
ISO 4113 or
SAE J967d

Distributor-type

ENGINE MODEL : R2

Injection pump No: 104648-0191 (NP-VE4/8F2125RNP247)

BOSCH No.9 460 610 146

DKKC No. 104748-0181

Date : 20.Nov.1986

Company : MAZDA

No. R209 13 800B

104748-0181 2/3

Pump rotation : clockwise-viewed from drive side

For Test Condition see
Microfiche No.WP-210(N16)

Pre-stroke : - mm

1. Setting	Pump speed (rpm)	Settings	Charge air press(mmHg)	Difference in delivery(cc)
1-1 Timing device travel	1,250	3.7~4.1 (mm)		
1-2 Supply pump pressure	1,250	4.9~5.5 (kg/cm ²)		
1-3 Full load delivery without charge air pressure	1,500	38.2~39.2 (cc/1,000st)		2.5
Full load delivery with charge air pressure		(cc/1,000st)		
1-4 Idle speed regulation	350	6.0~10.0 (cc/1,000st)		2.0
1-5 Start	100	Above 42.0 (cc/1,000st)		
1-6 Full-load speed regulation	2,400	11.1~15.1 (cc/1,000st)		
1-7 Load timer adjustment	1,250	3.1±0.2 (mm)		
1-8				

2. Test Specifications

2-1 Timing device	N = rpm	1,250	1,500	2,125
	mm	3.6~4.2	4.6~5.8	8.2~9.4
2-2 Supply pump	N = rpm	500	1,250	2,125
	kg/cm ²	2.7~3.3	4.9~5.5	7.3~7.9
2-3 Overflow delivery	N = rpm	1,250		
	cc/10s	49.7~93.7		

2-4 Fuel deliveries

Speed control lever	Pump speed (rpm)	Fuel delivery (cc/1,000st)	Charge air press(mmHg)	Difference in delivery
End stop	2,550	Below 4.0		
	2,400	10.1~16.1		
	2,125	32.0~36.0		
	1,500	37.7~39.7		
	500	30.7~34.7		
Switch OFF	350	0		
Idle stop	350	6.0~10.0		
2-5 Solenoid	Max.cut-in voltage : 8 V Test voltage : 12~14 V			

3. Dimensions

K	3.2 ~3.4 mm
KF	5.7 ~5.9 mm
MS	1.4 ~1.6 mm
BCS	- mm

Control lever angle

α	26.0~34.0 deg
A	4.0~9.5 mm
β	40.0~50.0 deg
B	12.5~15.8 mm
γ	- deg
C	- mm

LOAD TIMER ADJUSTMENT

1) Adjustment

① Fix the control lever in the position satisfying the following conditions.

Boost Pressure : - mmHg

Pump Speed : 1250 rpm

Fuel Injection : 28.2±1 cc/1000st

Quantity

② With the control lever positioned as described in ① above, adjust the governor sleeve so that

Timer Stroke conforms to the specified values (page 1/3).

2) Confirmation of Timer Characteristics

Fix the control lever in the position satisfying the following conditions, and confirm the Timer Stroke.

Control lever position			Specified Values	
Pump speed (rpm)	Fuel Injection Quantity(cc/1000st)	Boost pressure (mmHg)	Timer stroke (mm)	Timer stroke reduction value (mm)
1,250	28.2±1.5	-	3.1±0.3	-
1,250	18.1±1.5	-	1.9±0.7	-

M-CSD Assembly and Adjustment

1) Fixing the M-CSD stopper

1. Fix the M-CSD assembly temporarily to the pump housing.
2. Turn the drive shaft at least two turns in the direction of pump rotation.
3. Turn the drive shaft slowly, and fix the drive shaft in a position where a load is applied (the point where the roller in the roller holder contacts the cam surface of the cam disc).
4. Move the CSD lever to the advance side.
5. Fix the CSD lever in the position where the ball pin at the tip of the shaft lightly contacts the roller holder (roller holder advance angle "0").
6. Adjust the stopper position so that the gap between the CSD lever and the stopper is 0.5 ± 2 mm.
7. After adjustment, tighten the M-CSD screw to the specified torque.

$T=0.6-0.9 \text{ kg} \cdot \text{m}$

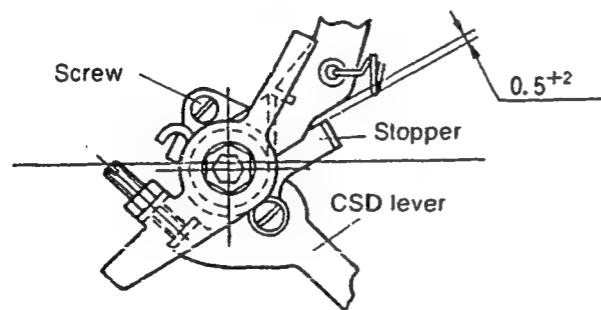

2) FICD screw adjustment

1. Move the CSD lever so that it contacts the stopper.
2. Insert a block gauge (thickness gauge) of 4.8 ± 1 mm thickness between the control lever and idling stopper bolt. (Position 7° from idle)
3. Adjust using the FICD screw so that the control lever and FICD screw are in contact.

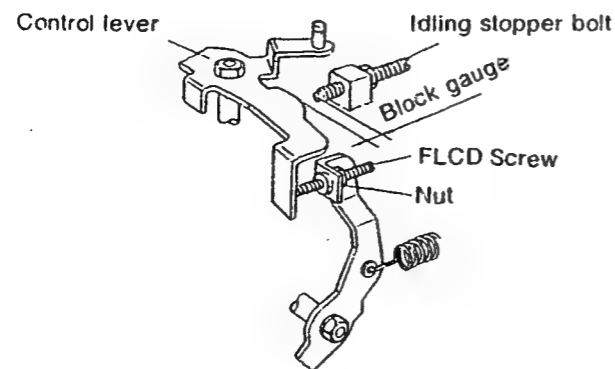

INJ. PUMP CALIBRATION DATA
Distributor-type

TEST OIL:
I S O 4113 or
S A E J967d

ENGINE MODEL : R2

BOSCH No. 9 460 610 192 1/4
DKKC No. 104748-0182
Date : 20.Nov.1986
Company : MAZDA
No. R209 13 800D

104748-0182 2/4

Injection pump No: 104648-0192 [NP-VE4/8F2125RNP247]

Pump rotation : clockwise-viewed from drive side
Pre-stroke : — mm

For Test Condition see
Microfiche No.WP-210(N16)

1. Setting	Pump speed (rpm)	Settings	Charge air press(mmHg)	Difference in delivery(cc)
1-1 Timing device travel	1,250	3.3~ 3.7 (mm)		
1-2 Supply pump pressure	1,250	4.9~ 5.5 (kg/cm ²)		
1-3 Full load delivery without charge air pressure	1,500	38.2~39.2 (cc/1,000st)		2.5
Full load delivery with charge air pressure		(cc/1,000st)		
1-4 Idle speed regulation	350	6.0~10.0 (cc/1,000st)		2.0
1-5 Start	100	Above 42.0 (cc/1,000st)		
1-6 Full-load speed regulation	2,400	11.1~15.1 (cc/1,000st)		
1-7 Load-timer adjustment	1,250	2.7± 0.2 (mm)		
1-8				

2. Test Specifications

2-1 Timing device	N = rpm mm	1,250 3.2~ 3.8	1,500 4.1~ 5.3	2,125 7.0~ 8.2	
2-2 Supply pump	N = rpm kg/cm ²	500 2.7~ 3.3	1,250 4.9~ 5.5	2,125 7.3~ 7.9	
2-3 Overflow delivery	N = rpm cc/10s	1,250 49.7~93.7			
2-4 Fuel deliveries	Speed control lever	Pump speed (rpm)	Fuel delivery (cc/1,000st)	Charge air press(mmHg)	Difference in delivery
	End stop	1,500	37.7~39.7		
		500	30.7~34.7		
		2,125	32.0~36.0		
		2,400	10.1~16.1		
		2,550	Below 4.0		
	Switch OFF	350	0		
	Idle stop	350	6.0~10.0		
2-5 Solenoid		Max.cut-in voltage : 8 V Test voltage : 12~14 V			

3. Dimensions

K	3.2~3.4 mm
KF	5.7~5.9 mm
MS	1.4~1.6 mm
BCS	— mm
Control lever angle	
α	28.0~32.0 deg
A	5.4~8.2 mm
β	40.0~50.0 deg
B	12.5~15.8 mm
γ	— deg
C	— mm

LOAD TIMER ADJUSTMENT

1) Adjustment

① Fix the control lever in the position satisfying the following conditions.

Boost Pressure : — mmHg
Pump Speed : 1250 rpm
Fuel Injection : 28.2±1 cc/1000st
Quantity

② With the control lever positioned as described in ① above, adjust the governor sleeve so that the Timer Stroke conforms to the specified values (page 1/4)

2) Confirmation of Timer Characteristics

Fix the control lever in the position satisfying the following conditions, and confirm the Timer Stroke.

Control lever position			Specified Values	
Pump speed (rpm)	Fuel Injection Quantity(cc/1000st)	Boost pressure (mmHg)	Timer stroke (mm)	Timer stroke reduction value (mm)
1250	28.2±1.5	—	2.7±0.3	—
1250	18.1±1.5	—	1.5±0.7	—

■ M-CSD Assembly and Adjustment

1) Fixing the M-CSD stopper

1. Fix the M-CSD assembly temporarily to the pump housing.
2. Turn the drive shaft at least two turns in the direction of pump rotation.
3. Turn the drive shaft slowly, and fix the drive shaft in a position where a load is applied (the point where the roller in the roller holder contacts the cam surface of the cam disc).
4. Move the CSD lever to the advance side.
5. Fix the CSD lever in the position where the ball pin at the tip of the shaft lightly contacts the roller holder (roller holder advance angle "0").
6. Adjust the adjusting screw so that the gap between the CSD lever and the stopper is 0.5 ± 2 mm.
7. After adjustment, tighten the M-CSD screw to the specified torque (T).

$$T = 0.6 \sim 0.9 \text{ kg} \cdot \text{m}$$

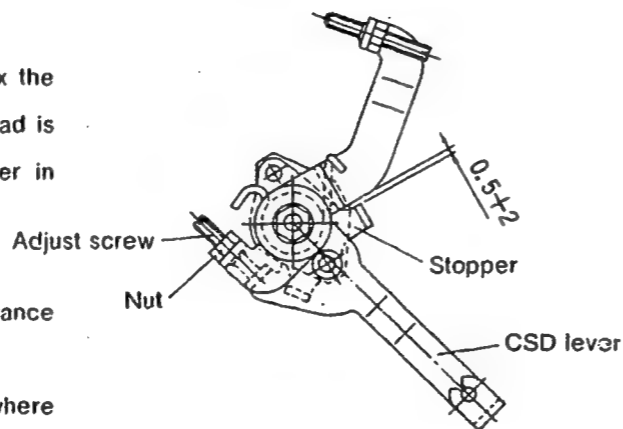

2) FICD screw adjustment

1. Move the CSD lever so that it contacts the stopper.
2. Insert a block gauge (thickness gauge) of 4.8 ± 1 mm thickness between the control lever and idling stopper bolt. (to position the control lever 7° from the idling position).
3. Adjust the FICD screw so that the control lever and the FICD screw are in contact.

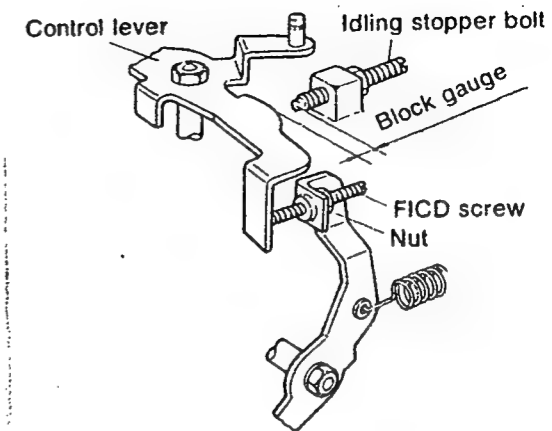

INJ. PUMP CALIBRATION DATA

TEST OIL:
I S O 4113 or
S A E J967d

Distributor-type

ENGINE MODEL : RF

BOSCH No.9 460 610 147
DKKC No. 104748-0243
Date : 20.Nov.1986
Company : MAZDA
No. RF39 13 800C

104748-0243 2/5

Injection pump No: 104648-0242 (NP-VE4/8F2325LNP351)

Pump rotation : Counter clockwise-viewed from drive side

For Test Condition see
Microfiche No.WP-210(N16)

Pre-stroke : - mm

1. Setting	Pump speed (rpm)	Settings	Charge air press(mmHg)	Difference in delivery(cc)
1-1 Timing device travel	1,375	4.0~ 4.4 (mm)		2.5
1-2 Supply pump pressure	1,375	4.4~ 5.0 (kg/cm ²)		
1-3 Full load delivery without charge air pressure	1,375	35.4~36.4 (cc/1,000st)		
		(cc/1,000st)		
1-4 Idle speed regulation	410	7.0~ 9.0 (cc/1,000st)		2.0
1-5 Start	100	Above 42.0 (cc/1,000st)		
1-6 Full-load speed regulation	2,600	10.8~14.8 (cc/1,000st)		
1-7 Load timer adjustment	1,375	3.6±0.2 (mm)		
1-8				

2. Test Specifications

2-1 Timing device	N = rpm	1,375	1,800	2,325	
	mm	3.9~ 4.5	6.1~ 7.3	7.2~ 8.4	
2-2 Supply pump	N = rpm	600	1,375	2,325	
	kg/cm ²	2.2~ 2.8	4.4~ 5.0	6.9~ 7.5	
2-3 Overflow delivery	N = rpm	1,375			
	cc/10s	46.3~90.3			
2-4 Fuel deliveries	Speed control lever	Pump speed (rpm)	Fuel delivery (cc/1,000st)	Charge air press(mmHg)	Difference in delivery
	End stop	2,700	Below 6.0		
		2,600	9.6~15.8		
		2,325	30.2~34.2		
		1,375	34.9~36.9		
		600	29.0~33.0		
	Switch OFF	410	0		
	Idle stop	410	6.0~10.0		
2-5 Solenoid	Max.cut-in voltage : 8 V Test voltage : 12~14 V				

3. Dimensions

K	3.2 ~3.4	mm
KF	5.7 ~5.9	mm
MS	1.4 ~1.6	mm
BCS	-	mm

Control lever angle

α	16.0~24.0	deg
A	5.7~10.9	mm
β	40.0~50.0	deg
B	12.7~16.0	mm
γ	-	deg
C	-	mm

LOAD TIMER ADJUSTMENT

1) Adjustment

① Fix the control lever in the position satisfying the following conditions.

Boost Pressure : - mmHg
Pump Speed : 1375 rpm
Fuel Injection : 28.2±1 cc/1000st
Quantity

② With the control lever positioned as described in ① above, adjust the governor sleeve so that

Timer Stroke conforms to the specified values (page 1/5).

2) Confirmation of Timer Characteristics

Fix the control lever in the position satisfying the following conditions, and confirm the Timer Stroke.

Control lever position			Specified Values	
Pump speed (rpm)	Fuel Injection Quantity(cc/1000st)	Boost pressure (mmHg)	Timer stroke (mm)	Timer stroke reduction value (mm)
1,375	28.2±1.5	-	3.6±0.3	-
1,375	16.1±1.5	-	2.4±0.7	-



DIESEL KIKI

DIESEL KIKI CO. LTD. 3-6-7 SHIBUYA, SHIBUYA-KU, TOKYO 150, JAPAN
Service Department Tel. (03) 400-1551 Fax: (03) 499-4115

Side Link Lever Adjustment

1) Side link lever adjustment

1. Fix the control lever in the idling position.
2. Check that side link levers (1) and (2) contact the stoppers. (Portion A)

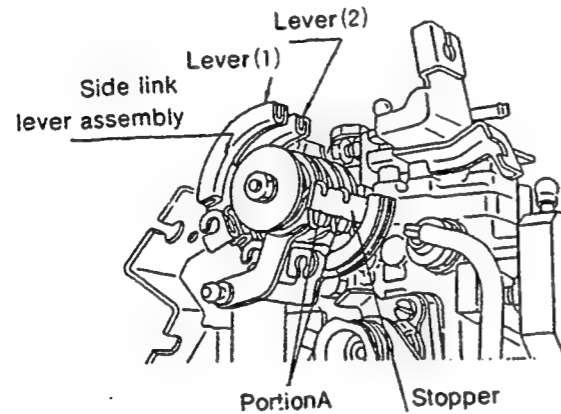

3. If control lever (4) and lever (3) are not connected by rod (5), connect them.
4. After connecting rod (5), adjust the length of rod (5) so that the gap at the hook of lever (3) and levers (1) and (2) is 0.5 ± 1.0 mm.

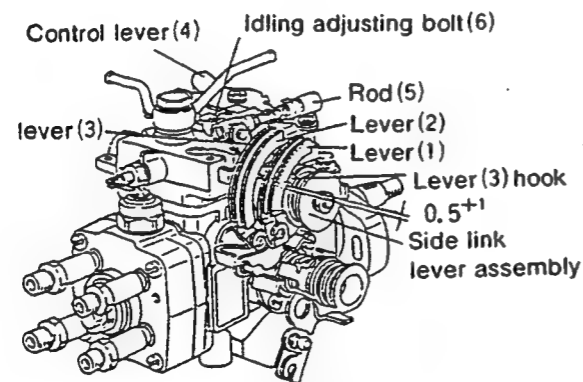

2) M-CSD adjustment

1. Loosen M-CSD lock screw (7).
2. Turn the drive shaft two or three turns and set the measuring device at 0.
3. Move the CSD lever gently in the direction of the arrow (advance direction).
4. Fix the CSD lever in a position where the CSD lever shaft ball pin contacts the roller holder. (Move gently, and hold the CSD lever in the position where the resistance changes.)
5. Check that the measuring device is at the 0 point.
6. Adjust the position of the stopper so that the gap between CSD lever (8) and stopper (9) is 0.5 ± 2 mm, and then fix in position using screw (7).
7. Turn the drive shaft two or three turns, check the position of the measuring device 0 point, and then recheck the gap between CSD lever (8) and stopper (9).

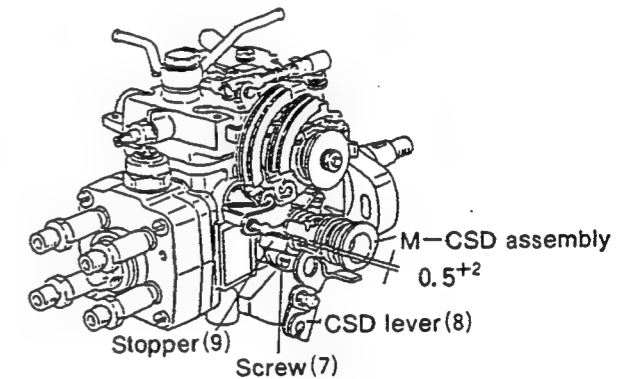
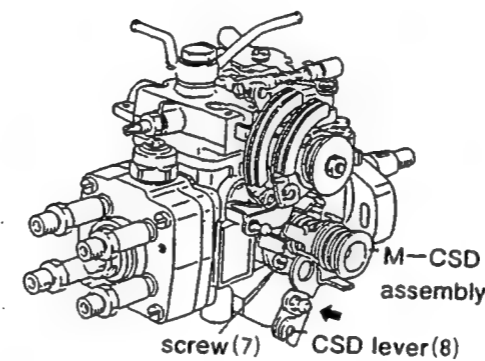

3) Fixing the CSD lever and side link lever connecting rod

1. Connect the side link lever assembly and CSD lever using rod (10).
2. Move the CSD lever through its full stroke (in the direction the arrow).
3. Adjust the length of rod (10) so that the gap between control lever (4) and idling adjusting bolt (6) is 8.5 mm, and then fix in this position. (Target engine speed: 1900rpm)

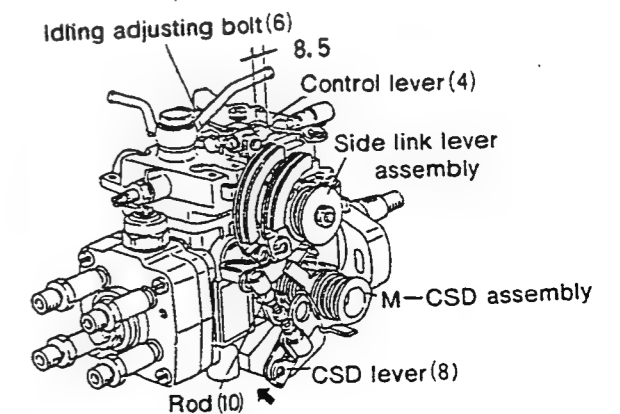

104748-0243 5/5

4) Fixing the engine installation bracket

1. Fix the bracket temporarily to the pump.
2. Move the bracket in the direction of the arrow until the clearance is 0.
3. Fix the bracket in position using the bolts.

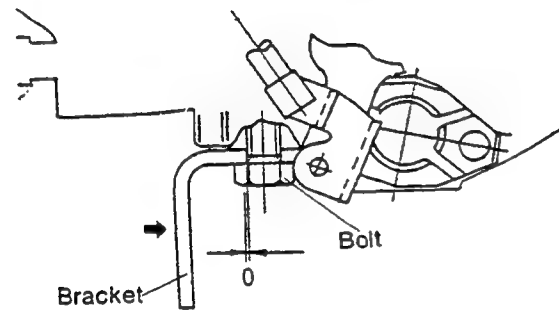
**○ DASH POT ADJUSTMENT**

- ① Insert a block gauge (thickness gauge) of thickness 8.5 in the gap between the control lever and the idling stopper bolt. (control lever angle : 13°)
- ② With the control lever positioned as described in ① above, adjust the Dashpot adjusting screw so that the Dashpot adjusting screw and the push rod are in contact. Fix using the nut.

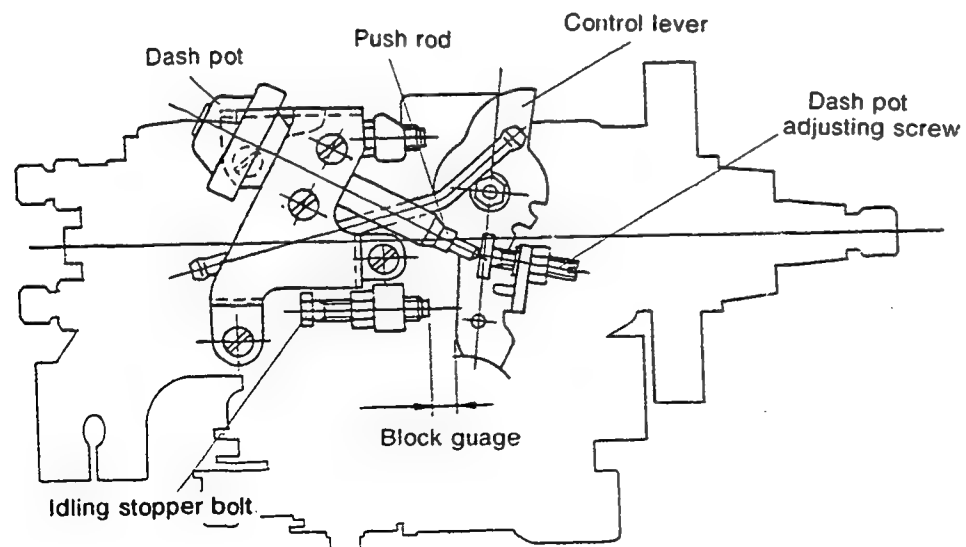

INJ. PUMP CALIBRATION DATA

Distributor-type

TEST OIL:
I S O 4113 or
S A E J967d

ENGINE MODEL : CD17

Injection pump No: 104648-2001 [NP-VE4/8F2500LNP134]

BOSCH No.9 460 610 012

DKKC No. 104748-2011

Date : 20.Nov.1986 [3]

Company : NISSAN

No. 16700 16A10

Pump rotation : Counter clockwise-viewed from drive side

For Test Condition see
Microfiche No.WP-210(N16)

Pre-stroke : — mm

1. Setting		Pump speed (rpm)	Settings	Charge air press(mmHg)	Difference in delivery(cc)
1-1	Timing device travel	1,200	1.8~ 2.4 (mm)		2.5
1-2	Supply pump pressure	1,200	3.1~ 3.7 (kg/cm ²)		
1-3	Full load delivery without charge air pressure Full load delivery with charge air pressure	1,200	29.5~30.5 (cc/1,000st) (cc/1,000st)		
1-4	Idle speed regulation	400	5.3~ 8.3 (cc/1,000st)		
1-5	Start	100	50~70 (cc/1,000st)		
1-6	Full-load speed regulation	2,700	11.9~17.9 (cc/1,000st)		
1-7					
1-8					

2. Test Specifications

2-1	Timing device	N = rpm mm	1,200 1.7~ 2.5	1,800 4.0~ 5.2	2,500 6.8~ 8.0
2-2	Supply pump	N = rpm kg/cm ²	1,200 3.0~ 3.8	1,800 4.4~ 5.2	2,500 6.1~ 6.9
2-3	Overflow delivery	N = rpm cc/10s	1,200 36.0~80.0		
2-4 Fuel injection quantities					
	Speed control lever position	Pump speed (rpm)	Fuel delivery (cc/1,000st)	Charge air press(mmHg)	Difference in delivery(cc)
	Full speed position	1,200	29.0~31.0		
		600	24.8~28.8		
		2,500	26.7~30.7		
		2,700	11.4~18.4		
		2,900	Below 6		
	Switch OFF	400	0		
	Idling position	400	4.8~ 8.8		
		600	Below 3		
	Partial load	700	10.0~20.0		
2-5	Solenoid	Max.cut-in voltage : 8 V Test voltage : 12~14 V			

3. Dimensions

K	3.2~3.4	mm
KF	5.7~5.9	mm
MS	1.5~1.7	mm
BCS	—	mm

Control lever angle

α	21.0~29.0	deg
A	2.5~ 8.0	mm
β	39.0~49.0	deg
B	11.0~16.0	mm
γ	13.5~14.5	deg
C	8.6~ 9.2	mm

INJ. PUMP CALIBRATION DATA

Distributor-type

TEST OIL:
I S O 4113 or
S A E J967d

ENGINE MODEL : CD17

BOSCH No.9 460 610 149

DKKC No. 104748-2410

Date: 20.Nov.1986 1

Company: NISSAN

No. 16700 54A00

1/4

104748-2410 2/4

Injection pump No: 104648-2410 [NP-VE4/8F2500LNP374]

Pump rotation : Counter clockwise-viewed from drive side

For Test Condition see
Microfiche No.WP-210(N16)

Pre-stroke : - mm

1. Setting	Pump speed (rpm)	Settings	Charge air press(mmHg)	Difference in delivery(cc)
1-1 Timing device travel	1,200	1.5~ 2.1 (mm)		2.5
1-2 Supply pump pressure	1,200	3.1~ 3.7 (kg/cm ²)		
1-3 Full load delivery without charge air pressure	1,000	28.1~29.1 (cc/1,000st)		
Full load delivery with charge air pressure		(cc/1,000st)		
1-4 Idle speed regulation	360	3.7~ 6.7 (cc/1,000st)		
1-5 Start	100	45.3~55.3 (cc/1,000st)		
1-6 Full-load speed regulation	2,700	11.8~17.8 (cc/1,000st)		
1-7				
1-8				

2. Test Specifications

2-1 Timing device	N = rpm	1,200	1,800	2,500
	mm	1.4~ 2.2	3.5~ 4.7	6.9~ 7.8
2-2 Supply pump	N = rpm	1,200	1,800	2,500
	kg/cm ²	3.0~ 3.8	4.4~ 5.2	6.1~ 6.9
2-3 Overflow delivery	N = rpm	1,200		
	cc/10s	36.0~80.0		

2-4 Fuel deliveries

Speed control lever	Pump speed (rpm)	Fuel delivery (cc/1,000st)	Charge air press(mmHg)	Difference in delivery
End stop	2,900	Below 6.0		
	2,700	11.3~18.3		
	2,500	25.3~29.3		
	1,000	27.6~29.6		
	600	25.8~29.8		
Switch OFF	360	0		
Idle stop	360	3.2~ 7.2		2.5
	600	Below 3.0		
Partial load	700	10.8~19.8		
2-5 Solenoid	Max.cut-in voltage : 8 V Test voltage : 12~14 V			

3. Dimensions

K	3.2 ~3.4	mm
KF	5.7 ~5.9	mm
MS	1.5 ~1.7	mm
BCS	-	mm

Control lever angle

α	1.0~-1.0	deg
YA	15.4~18.1	mm
β	39.0~49.0	deg
B	11.0~16.0	mm
Y	13.5~14.5	deg
C	8.6~ 9.2	mm

○Control Lever Angle Measurement Position

①Measure the control lever angle (α, β, γ) at hole A.

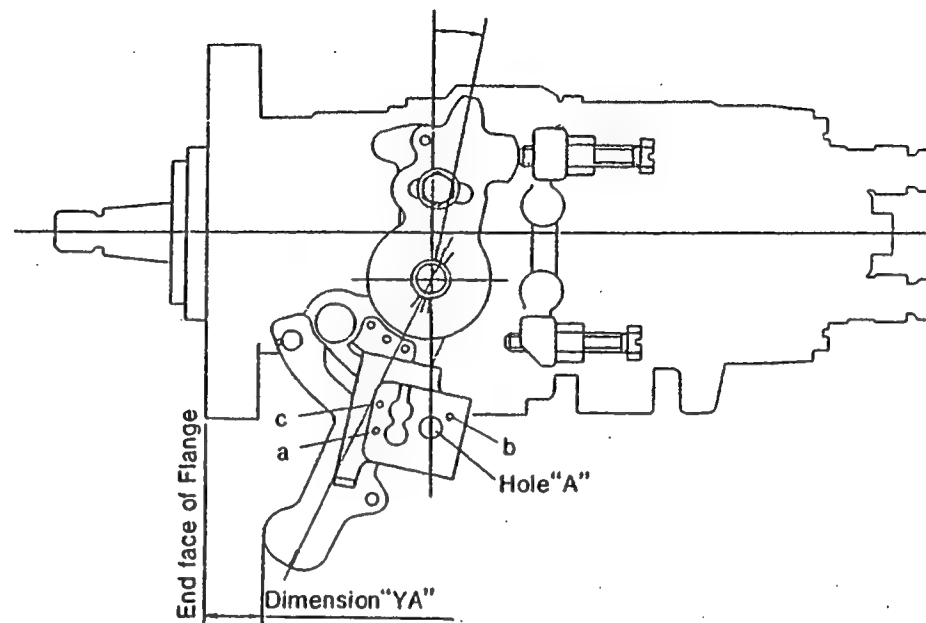

○Starting Injection Quantity Adjustment

Adjust the starting Injection Quantity (item 1 - 5) using the adjusting bolt (as shown in the figure at below) .

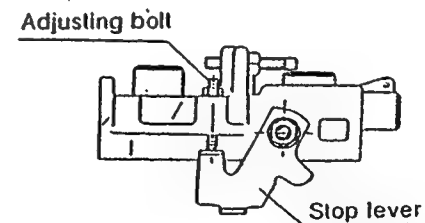

OW-CSD Adjustment

1) Timer stroke adjustment

1. Calculate the timer stroke from Fig. 2 according to the atmospheric temperature at the time of adjustment.
2. Adjust using timer stroke adjusting screw so that the timer stroke is as calculated in Step 1.

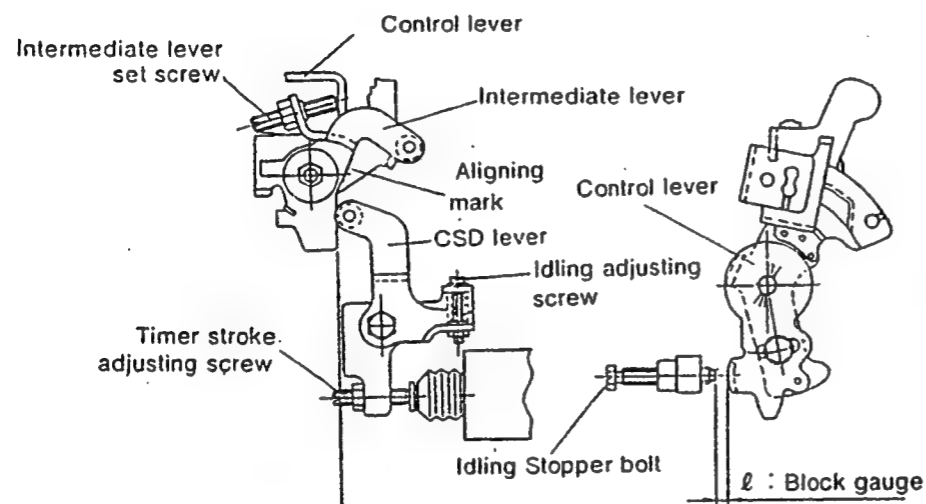

Fig. 1

Formula for calculating Fig. 2 $10 \leq t \leq 20$ $T = -0.027t + 1.09$

Formula for calculating timer stroke: $20 \leq t \leq 40$ $T = -0.0275t + 1.1$

Formula for calculating control lever $t \leq 10$ $l = 4.6$

and idling stopper bolt gap: $10 < t \leq 20$ $l = -0.17t + 6.3$

$20 < t \leq 28.5$ $l = -0.235t + 7.6$

$28.5 < t \leq 36$ $l = -0.12t + 4.32$

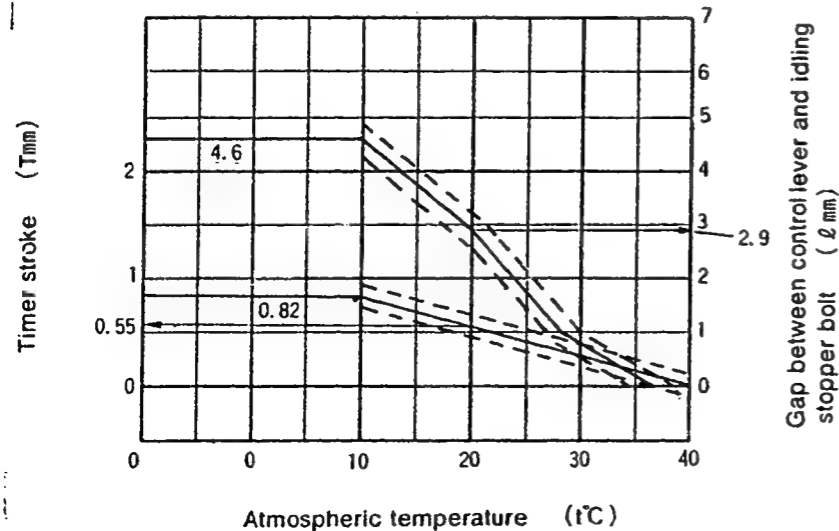

Fig. 2

2) Intermediate lever position adjustment

1. Insert a block gauge (thickness gauge) of 4.1 ± 0.05 mm thickness between the control lever and the idling stopper bolt.
2. Align the intermediate lever with the aligning mark.
3. Adjust the intermediate lever set screw so that the control lever and intermediate lever set screw are in contact, and then fix in position using the locknut.

3) CSD lever adjustment

1. Calculate the block gauge dimension $l \pm 0.05$ mm from Fig. 2 according to the atmospheric temperature at the time of adjustment.
2. Insert the block gauge (thickness gauge) selected in Step(1) above between the bracket and the idling stopper bolt.
3. Using the idling bolt, adjust so that the CSD lever roller and intermediate lever are in contact.

Note:

1. The temperature of the wax must be below 30°C when adjusting.
2. When inserting a block gauge (thickness gauge) between the control lever (beacket) and the idling stopper bolt, use the idling adjusting bolt to separate the CSD lever and intermediate lever so that no excessive force is exerted on them.

INJ. PUMP CALIBRATION DATA

Distributor-type

TEST OIL:
ISO 4113 or
SAE J967d

ENGINE MODEL : CD17

Injection pump No: 104648-2410 (NP-VE4/8F2500LNP374)

BOSCH No.9 460 610 150
DKKC No. 104748-2420
Date: 20.Nov.1986
Company: NISSAN
No. 16700 54A10

1/4

Pump rotation : Counter clockwise-viewed from drive side
Pre-stroke : - mm

For Test Condition see
Microfiche No.WP-210(N16)

1. Setting	Pump speed (rpm)	Settings	Charge air press(mmHg)	Difference in delivery(cc)
1-1 Timing device travel	1,200	1.5~ 2.1 (mm)		2.5
1-2 Supply pump pressure	1,200	3.1~ 3.7 (kg/cm ²)		
1-3 Full load delivery without charge air pressure Full load delivery with charge air pressure	1,000	28.1~29.1 (cc/1,000st) (cc/1,000st)		
1-4 Idle speed regulation	360	3.7~ 6.7 (cc/1,000st)		
1-5 Start	100	45.3~55.3 (cc/1,000st)		
1-6 Full-load speed regulation	2,700	11.8~17.8 (cc/1,000st)		
1-7				
1-8				

2. Test Specifications

2-1 Timing device	N = rpm mm	1,200 1.4~ 2.2	1,800 3.5~ 4.7	2,500 6.9~ 7.8
2-2 Supply pump	N = rpm kg/cm ²	1,200 3.0~ 3.8	1,800 4.4~ 5.2	2,500 6.1~ 6.9
2-3 Overflow delivery	N = rpm cc/10s	1,200 36.0~80.0		

2-4 Fuel deliveries	Speed control lever	Pump speed (rpm)	Fuel delivery (cc/1,000st)	Charge air press(mmHg)	Difference in delivery
	End stop	2,900	Below 6.0		
		2,700	11.3~18.3		
		2,500	25.3~29.3		
		1,000	27.6~29.6		
		600	25.8~29.8		
Switch OFF		360	0		
		600	3.2~ 7.2 Below 3.0		2.5
Partial load		700	10.8~19.8		
2-5 Solenoid	Max.cut-in voltage : 8 V Test voltage : 12~14 V				

3. Dimensions

K	3.2 ~3.4 mm
KF	5.7 ~5.9 mm
MS	1.5 ~1.7 mm
BCS	- mm

Control lever angle

α	1.0~-1.0 deg
YA	15.4~18.1 mm
β	39.0~49.0 deg
B	11.0~16.0 mm
γ	13.5~14.5 deg
C	8.6~ 9.2 mm

○Control Lever Angle Measurement Position

①Measure the control lever angle (α, β, γ) at hole A.

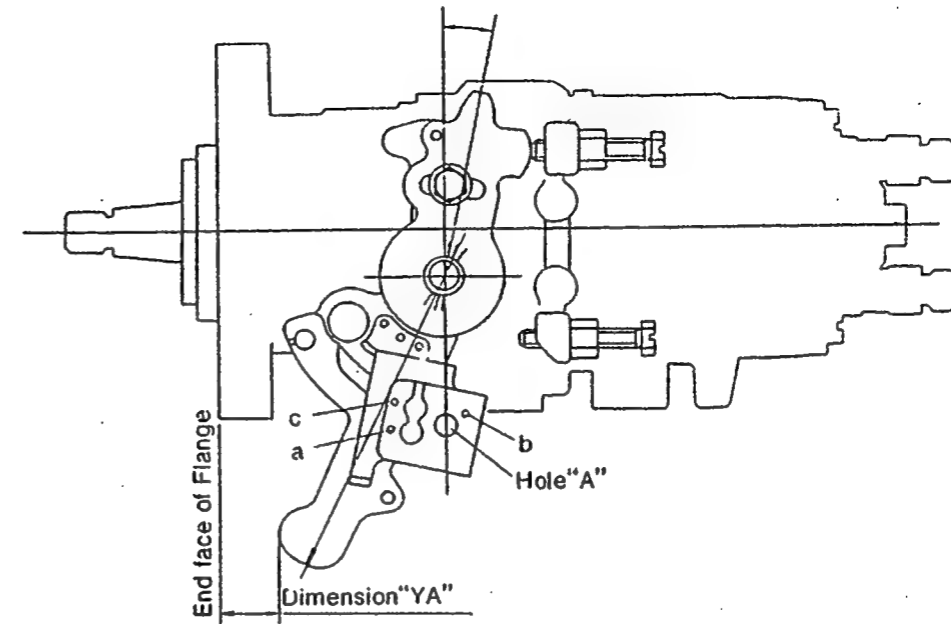

○Starting Injection Quantity Adjustment

Adjust the starting Injection Quantity (item 1 - 5) using the adjusting bolt (as shown in the figure at below) .

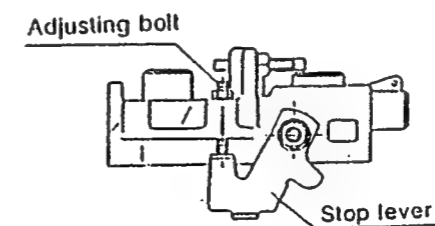

OW-CSD Adjustment

1) Timer stroke adjustment

1. Calculate the timer stroke from Fig. 2 according to the atmospheric temperature at the time of adjustment.
2. Adjust using timer stroke adjusting screw so that the timer stroke is as calculated in Step 1.

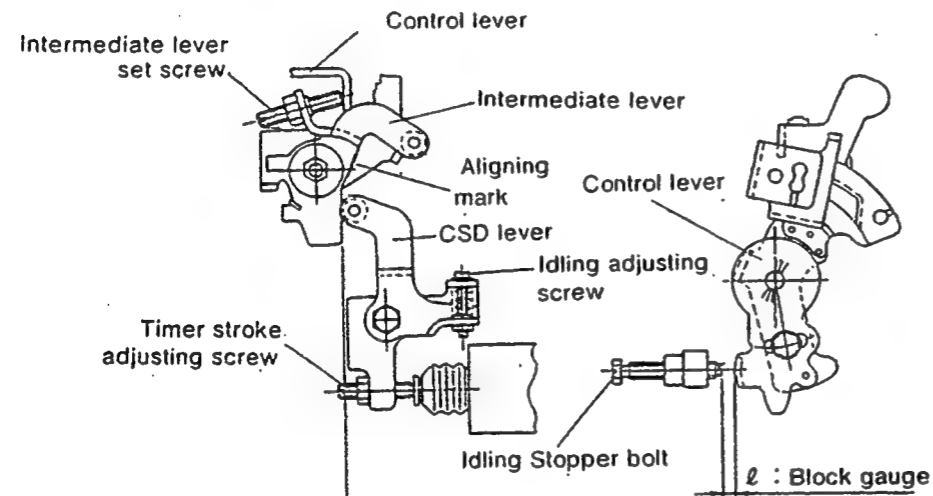

Fig. 1

Formula for calculating Fig. 2:

$$10 \leq t \leq 20 \quad T = -0.027t + 1.09$$

Formula for calculating timer stroke:

$$20 \leq t \leq 40 \quad T = -0.0275t + 1.1$$

Formula for calculating control lever and idling stopper bolt gap:

$$t \leq 10 \quad l = 4.6$$

$$10 < t \leq 20 \quad l = -0.17t + 6.3$$

$$20 < t \leq 28.5 \quad l = -0.235t + 7.6$$

$$28.5 < t \leq 36 \quad l = -0.12t + 4.32$$

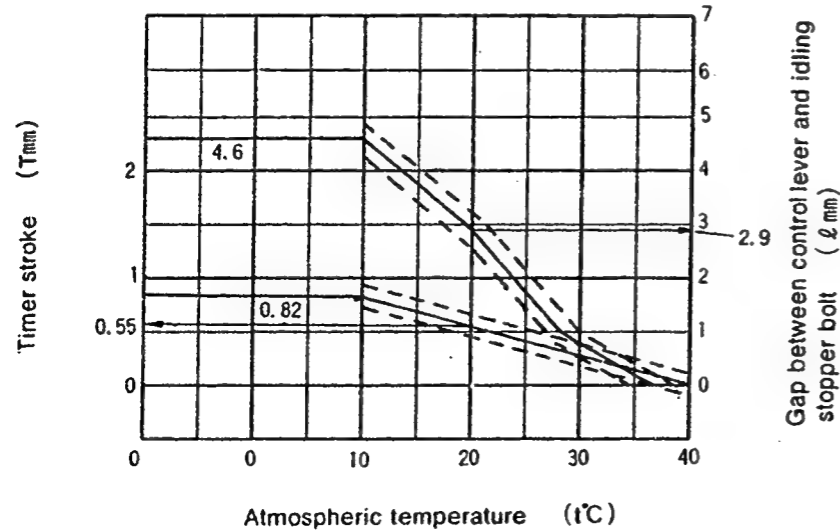

Fig. 2

2) Intermediate lever position adjustment

1. Insert a block gauge (thickness gauge) of 4.1 ± 0.05 mm thickness between the control lever and the idling stopper bolt.
2. Align the intermediate lever with the aligning mark.
3. Adjust the intermediate lever set screw so that the control lever and intermediate lever set screw are in contact, and then fix in position using the locknut.

3) CSD lever adjustment

1. Calculate the block gauge dimension $l \pm 0.05$ mm from Fig. 2 according to the atmospheric temperature at the time of adjustment.
2. Insert the block gauge (thickness gauge) selected in Step(1) above between the bracket and the idling stopper bolt.
3. Using the idling bolt, adjust so that the CSD lever roller and intermediate lever are in contact.

Note:

1. The temperature of the wax must be below 30°C when adjusting.
2. When inserting a block gauge (thickness gauge) between the control lever (beacket) and the idling stopper bolt, use the idling adjusting bolt to separate the CSD lever and intermediate lever so that no excessive force is exerted on them.

INJ. PUMP CALIBRATION DATA
Distributor-type

TEST OIL:
I S O 4113 or
S A E J967d

ENGINE MODEL : CD17

BOSCH No.9 460 610 151 1/4
DKKC No. 104748-2430
Date : 20.Nov.1986
Company : NISSAN
No. 16700 54A05

104748-2430 2/4

Injection pump No: 104648-2410 [NP-VE4/8F2500LNP374]

Pump rotation : Counter clockwise-viewed from drive side

For Test Condition see
Microfiche No.WP-210(N16)

Pre-stroke : - mm

1. Setting	Pump speed (rpm)	Settings	Charge air press(mmHg)	Difference in delivery(cc)
1-1 Timing device travel	1,200	1.5~ 2.1 (mm)		2.5
1-2 Supply pump pressure	1,200	3.1~ 3.7 (kg/cm ²)		
1-3 Full load delivery without charge air pressure	1,000	28.1~29.1 (cc/1,000st)		
Full load delivery with charge air pressure		(cc/1,000st)		
1-4 Idle speed regulation	360	6.6~ 9.6 (cc/1,000st)		
1-5 Start	100	45.3~55.3 (cc/1,000st)		
1-6 Full-load speed regulation	2,700	11.8~17.8 (cc/1,000st)		
1-7				
1-8				

2. Test Specifications

2-1 Timing device	N = rpm mm	1,200 1.4~ 2.2	1,800 3.5~ 4.7	2,500 6.9~ 7.8
2-2 Supply pump	N = rpm kg/cm ²	1,200 3.0~ 3.8	1,800 4.4~ 5.2	2,500 6.1~ 6.9
2-3 Overflow delivery	N = rpm cc/10s	1,200 36.0~80.0		

2-4 Fuel deliveries

Speed control lever	Pump speed (rpm)	Fuel delivery (cc/1,000st)	Charge air press(mmHg)	Difference in delivery
End stop	2,900	Below 6.0		
	2,700	11.3~18.3		
	2,500	25.3~29.3		
	1,000	27.6~29.6		
	600	25.8~29.8		
Switch OFF	360	0		
Idle stop	360	6.1~10.1		2.5
	600	Below 3.0		
Partial load	700	10.1~19.1		
2-5 Solenoid	Max.cut-in voltage : 8 V Test voltage : 12~14 V			

3. Dimensions

K	3.2 ~3.4 mm
KF	5.7 ~5.9 mm
MS	1.5 ~1.7 mm
BCS	- mm

Control lever angle

α	1.0~-1.0 deg
YA	15.4~18.1 mm
β	37.0~47.0 deg
B	10.7~14.8 mm
γ	10.5~11.5 deg
C	6.8~ 7.4 mm

○Control Lever Angle Measurement Position

①Measure the control lever angle (α, β, γ) at hole A.

②Marking positions

The control lever is marked (painted) at the positions shown below,depending on control lever angle β.

○Position "a" ⇨ β ≤ 39.5° (B=11.7mm)

○Position "b" ⇨ 39.5° (B=11.7mm) < β ≤ 42.5° (B=13.0mm)

○Position "c" ⇨ β > 42.5° (B=13.0mm)

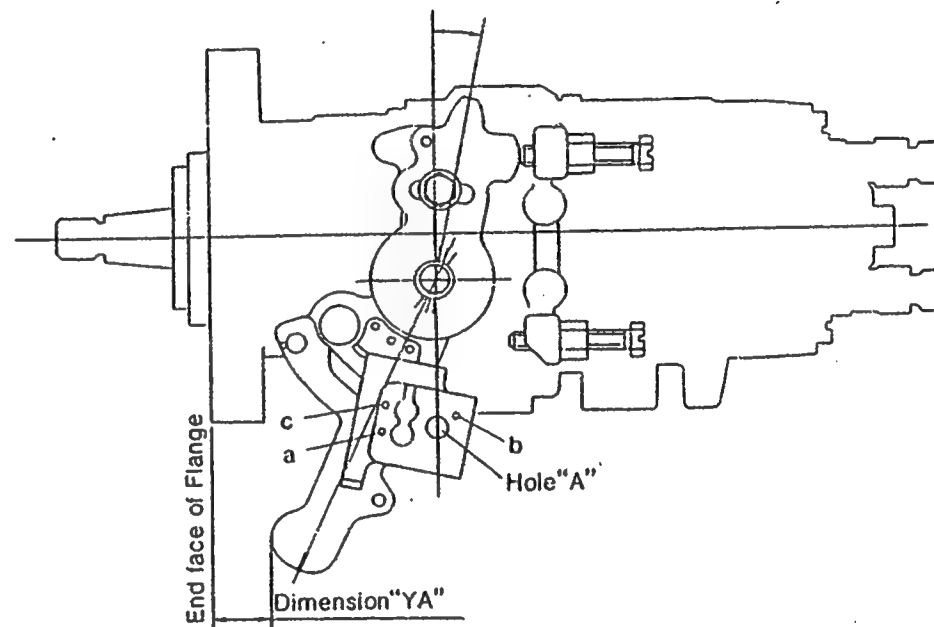

○Starting Injection Quantity Adjustment

Adjust the starting Injection Quantity (item 1 - 5) using the adjusting bolt (as shown in the figure at below) .

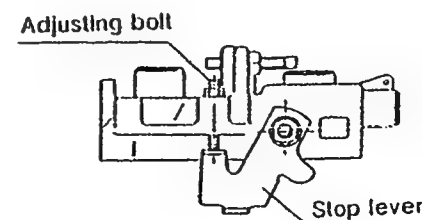

OW-CSD Adjustment

1) Timer stroke adjustment (adjust to the thick line)

1. Calculate the timer stroke from Fig. 2 according to the atmospheric temperature at the time of adjustment.
2. Adjust using timer stroke adjusting screw so that the timer stroke is as calculated in Step 1.

2) Intermediate lever position adjustment

1. Insert a block gauge (thickness gauge) of $4.1 \pm 0.05\text{mm}$ thickness between the control lever and the idling stopper bolt.
2. Align the intermediate lever with the aligning mark.
3. Adjust the intermediate lever set screw so that the control lever and intermediate lever set screw are in contact, and then fix in position using the locknut.

3) CSD lever adjustment

1. Calculate the block gauge dimension $\ell \pm 0.05\text{mm}$ from Fig. 2 according to the atmospheric temperature at the time of adjustment.
2. Insert the block gauge (thickness gauge) selected in Step (1) above between the bracket and the idling stopper bolt.
3. Using the idling bolt, adjust so that the CSD lever roller and intermediate lever are in contact.

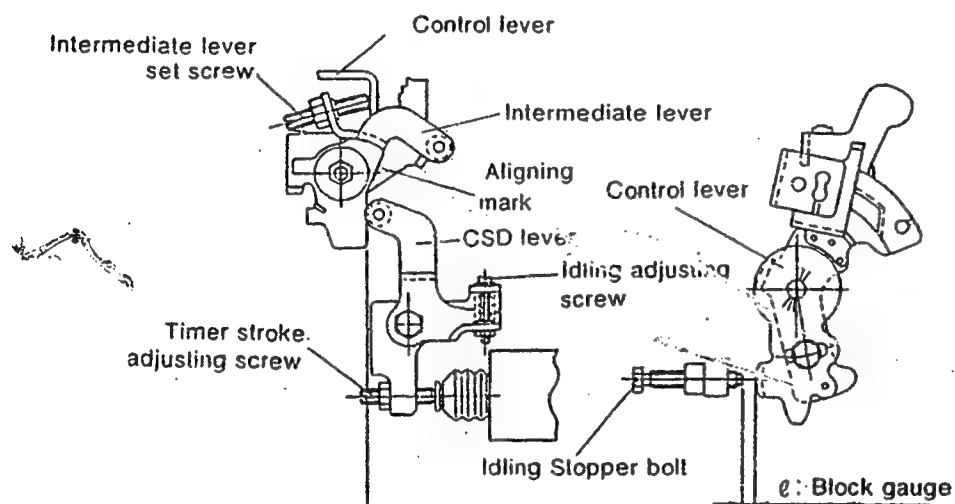

Fig. 1

Formula for calculating Fig. 2 $10 \leq t \leq 20 \quad T = -0.027t + 1.09$
 Formula for calculating timer stroke: $20 \leq t \leq 40 \quad T = -0.0275t + 1.1$
 $t \leq 10 \quad \ell = 4.6$
 Formula for calculating control lever and idling stopper bolt gap:
 $10 < t \leq 20 \quad \ell = -0.17t + 6.3$
 $20 < t \leq 28.5 \quad \ell = -0.235t + 7.6$
 $28.5 < t \leq 36 \quad \ell = -0.12t + 4.32$

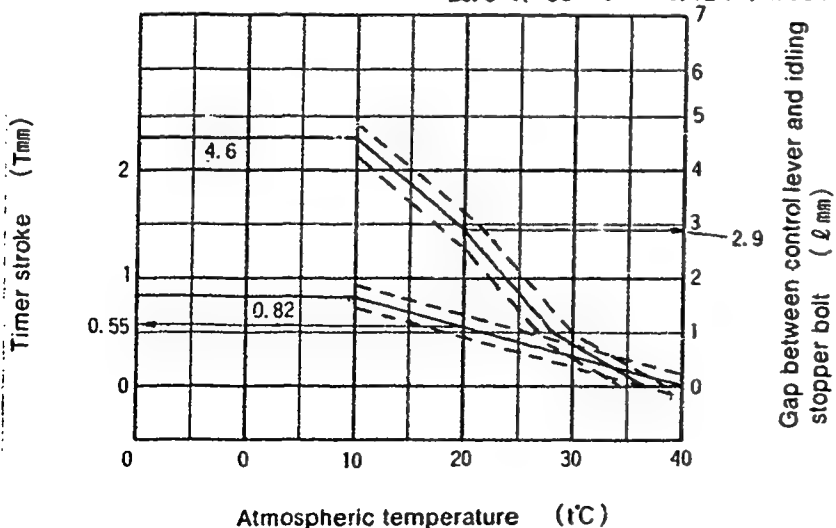

Fig. 2

Notes:

1. The temperature of the wax must be below 30°C when adjusting.
2. When inserting a block gauge (thickness gauge) between the control lever (beacket) and the idling stopper bolt, use the idling adjusting bolt to separate the CSD lever and intermediate lever so that no excessive force is exerted on them.

INJ. PUMP CALIBRATION DATA

Distributor-type

TEST OIL:
ISO 4113 or
SAE J967d

ENGINE MODEL : CD17

BOSCH No.9 460 610 152 1/4
DKKC No. 104748-2440
Date : 20.Nov.1986
Company : NISSAN
No. 16700 54A15

Injection pump No: 104648-2410 [NP-VE4/8F2500LNP374]

For Test Condition see
Microfiche No.WP-210(N16)

Pump rotation : Counter clockwise-viewed from drive side

Pre-stroke : mm

1. Setting	Pump speed (rpm)	Settings	Charge air press(mmHg)	Difference in delivery(cc)
1-1 Timing device travel	1,200	1.5~ 2.1 (mm)		2.5
1-2 Supply pump pressure	1,200	3.1~ 3.7 (kg/cm ²)		
1-3 Full load delivery without charge air pressure	1,000	28.1~29.1 (cc/1,000st)		
Full load delivery with charge air pressure		(cc/1,000st)		
1-4 Idle speed regulation	360	6.6~ 9.6 (cc/1,000st)		
1-5 Start	100	45.3~55.3 (cc/1,000st)		
1-6 Full-load speed regulation	2,700	11.8~17.8 (cc/1,000st)		
1-7				
1-8				

2. Test Specifications

2-1 Timing device	N = rpm	1,200	1,800	2,500
	mm	1.4~ 2.2	3.5~ 4.7	6.9~ 7.8
2-2 Supply pump	N = rpm	1,200	1,800	2,500
	kg/cm ²	3.0~ 3.8	4.4~ 5.2	6.1~ 6.9
2-3 Overflow delivery	N = rpm	1,200		
	cc/10s	36.0~80.0		

2-4 Fuel deliveries

Speed control lever	Pump speed (rpm)	Fuel delivery (cc/1,000st)	Charge air press(mmHg)	Difference in delivery
End stop	2,900	Below 6.0		
	2,700	11.3~18.3		
	2,500	25.3~29.3		
	1,000	27.6~29.6		
	600	25.8~29.8		
Switch OFF	360	0		
Idle stop	360	6.1~10.1		2.5
	600	Below 3.0		
Partial load	700	10.1~19.1		

3. Dimensions

K	3.2 ~3.4	mm
KF	5.7 ~5.9	mm
MS	1.5 ~1.7	mm
BCS	—	mm

Control lever angle

α	1.0~1.0	deg
YA	15.4~18.1	mm
β	37.0~47.0	deg
B	10.7~14.8	mm
γ	10.5~11.5	deg
C	6.8~ 7.4	mm

2-5 Solenoid Max.cut-in voltage : 8 V
Test voltage : 12~14 V

○Control Lever Angle Measurement Position

①Measure the control lever angle (α, β, γ) at hole A.

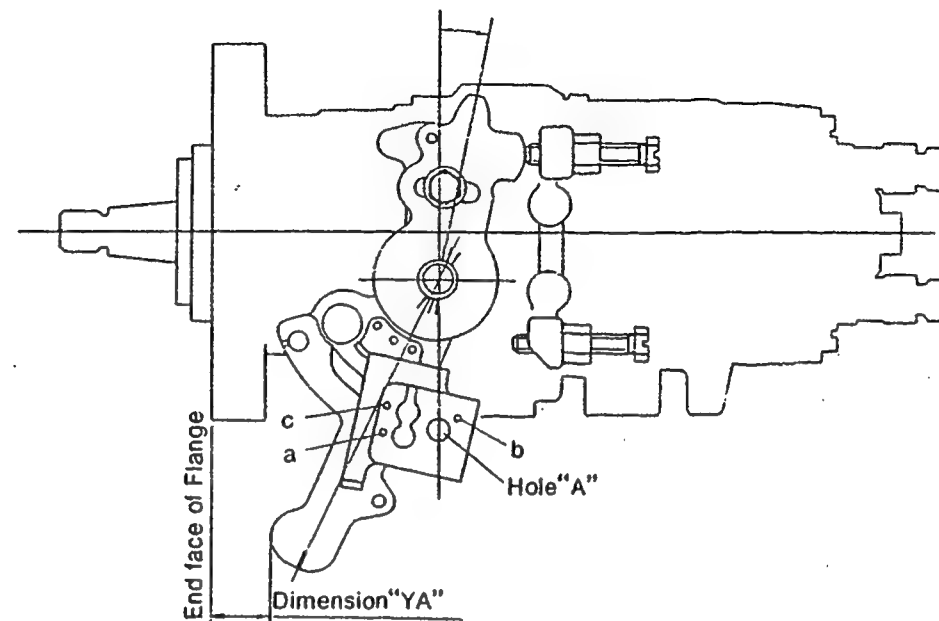

②Marking positions

The control lever is marked (painted) at the positions shown below, depending on control lever angle β .

○Position "a" $\Leftrightarrow \beta \leq 39.5^\circ$ (B=11.7mm)

○Position "b" $\Leftrightarrow 39.5^\circ$ (B=11.7mm) $< \beta \leq 42.5^\circ$ (B=13.0mm)

○Position "c" $\Leftrightarrow \beta > 42.5^\circ$ (B=13.0mm)

○Starting Injection Quantity Adjustment

Adjust the starting Injection Quantity (item 1-5) using the adjusting bolt (as shown in the figure at below).

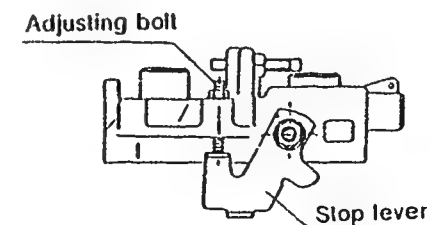

OW-CSD Adjustment

1) Timer stroke adjustment

1. Calculate the timer stroke from Fig. 2 according to the atmospheric temperature at the time of adjustment.
2. Adjust using timer stroke adjusting screw so that the timer stroke is as calculated in Step 1.

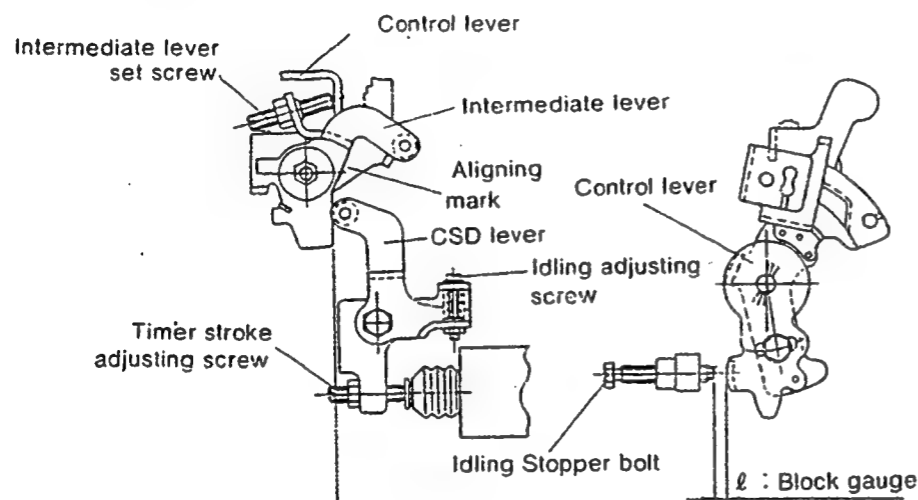

Fig. 1

Formula for calculating Fig. 2

Formula for calculating timer stroke:

Formula for calculating control lever and idling stopper bolt gap:

$$10 \leq t \leq 20 \quad T = -0.027t + 1.09$$

$$20 \leq t \leq 40 \quad T = -0.0275t + 1.1$$

$$t \leq 10 \quad l = 4.6$$

$$10 < t \leq 20 \quad l = -0.17t + 6.3$$

$$20 < t \leq 28.5 \quad l = -0.235t + 7.6$$

$$28.5 < t \leq 36 \quad l = -0.12t + 4.32$$

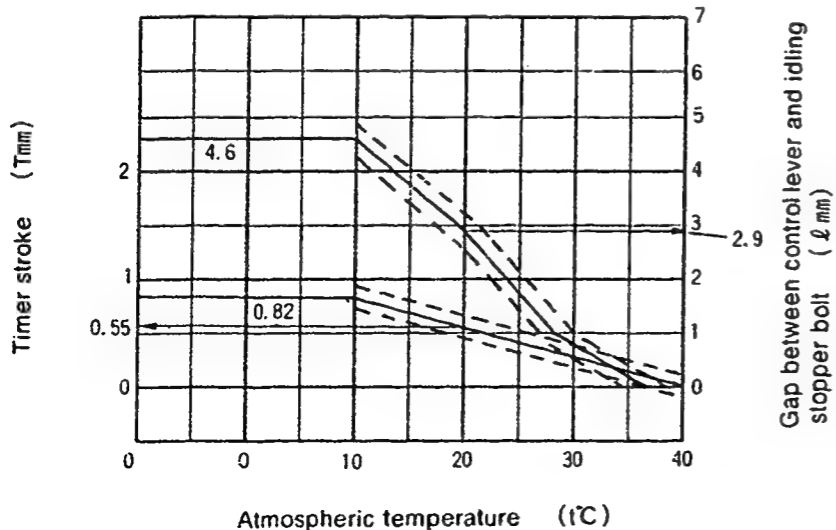

Fig. 2

2) Intermediate lever position adjustment

1. Insert a block gauge (thickness gauge) of 4.1 ± 0.05 mm thickness between the control lever and the idling stopper bolt.
2. Align the intermediate lever with the aligning mark.
3. Adjust the intermediate lever set screw so that the control lever and intermediate lever set screw are in contact, and then fix in position using the locknut.

3) CSD lever adjustment

1. Calculate the block gauge dimension $l \pm 0.05$ mm from Fig. 2 according to the atmospheric temperature at the time of adjustment.
2. Insert the block gauge (thickness gauge) selected in Step(1) above between the bracket and the idling stopper bolt.
3. Using the idling bolt, adjust so that the CSD lever roller and intermediate lever are in contact.

Note:

1. The temperature of the wax must be below 30°C when adjusting.
2. When inserting a block gauge (thickness gauge) between the control lever (becket) and the idling stopper bolt, use the idling adjusting bolt to separate the CSD lever and intermediate lever so that no excessive force is exerted on them.

INJ. PUMP CALIBRATION DATA Distributor-type

ENGINE MODEL : S2

TEST OIL:
I S O 4113 or
S A E J967d

Injection pump No: 104649-0040 (NP-VE4/9F2125LNP55)

Pump rotation : Counter clockwise-viewed from drive side

Pre-stroke : 0.08~0.12 mm

BOSCH No.9 460 610 172

DKKC No. 104749-0040

Date : 20.Nov.1986 (0)

Company : MAZDA

No. S201 13 800A

For Test Condition see
Microfiche No.WP-210(N16)

1. Setting	Pump speed (rpm)	Settings	Charge air press(mmHg)	Difference in delivery(cc)
1-1 Timing device travel	1,250	1.3~ 1.7 (mm)		
1-2 Supply pump pressure	1,250	3.8~ 4.4 (kg/cm ²)		
1-3 Full load delivery without charge air pressure	1,250	43.1~44.1 (cc/1,000st)		2.5
Full load delivery with charge air pressure		(cc/1,000st)		
1-4 Idle speed regulation	325	5.2~ 9.2 (cc/1,000st)		2.5
1-5 Start	100	Above 60 (cc/1,000st)		
1-6 Full-load speed regulation	2,400	13.6~17.6 (cc/1,000st)		
1-7				
1-8				

2. Test Specifications

2-1 Timing device	N = rpm	1,250	1,500	2,125
	mm	1.2~ 1.8	2.8~ 4.0	8.3~9.2
2-2 Supply pump	N = rpm	500	1,250	2,125
	kg/cm ²	1.3~ 1.9	3.8~ 4.4	6.8~ 7.4
2-3 Overflow delivery	N = rpm	1,250		
	cc/10s	52.0~95.0		

2-4 Fuel injection quantities

Speed control lever position	Pump speed (rpm)	Fuel delivery (cc/1,000st)	Charge air press(mmHg)	Difference in delivery(cc)
Full speed position	1,250	42.6~44.6		
	500	33.5~37.5		
	2,125	36.2~40.2		
	2,400	12.6~18.6		
	2,500	Below 10		
Switch OFF	325	0		
Idling position	325	5.2~ 9.2		
	Below 450	0		

3. Dimensions

K	3.2~3.4 mm
KF	5.7~5.9 mm
MS	1.7~1.9 mm
BCS	— mm

Control lever angle

α	31.0~39.0 deg
A	— mm
β	45.0~55.0 deg
B	— mm
γ	— deg
C	— mm

2-5 Solenoid Max.cut-in voltage : 8 V
Test voltage : 12~14 V

INJ. PUMP CALIBRATION DATA Distributor-type

ENGINE MODEL : 4FC1D

TEST OIL:
I S O 4113 or
S A E J967d

Injection pump No: 104649-1120 (NP-VE4/9F2250RNP49)

Pump rotation : clockwise-viewed from drive side

Pre-stroke : 0.23~0.27 mm

BOSCH No.9 460 610 105

DKKC No. 104749-1070

Date : 20.Nov.1986 (0)

Company : ISUZU

No. 894238 5370

For Test Condition see
Microfiche No.WP-210(N16)

1. Setting	Pump speed (rpm)	Settings	Charge air press(mmHg)	Difference in delivery(cc)
1-1 Timing device travel	1,250	2.4~ 2.8 (mm)		
1-2 Supply pump pressure	1,250	4.6~ 5.0 (kg/cm ²)		
1-3 Full load delivery without charge air pressure	1,250	34.5~35.5 (cc/1,000st)		2.5
Full load delivery with charge air pressure		(cc/1,000st)		
1-4 Idle speed regulation	315	5.5~ 9.5 (cc/1,000st)		2.0
1-5 Start	100	52.0~72.0 (cc/1,000st)		
1-6 Full-load speed regulation	2,600	14.2~16.2 (cc/1,000st)		
1-7				
1-8				

2. Test Specifications

2-1 Timing device	N = rpm	1,250	2,000	2,500
	mm	2.3~ 2.9	4.9~ 6.1	6.9~ 7.8
2-2 Supply pump	N = rpm	1,250	2,000	
	kg/cm ²	4.6~ 5.0	6.2~ 6.8	
2-3 Overflow delivery	N = rpm	1,250		
	cc/10s	58.0~102.0		

2-4 Fuel injection quantities

Speed control lever position	Pump speed (rpm)	Fuel delivery (cc/1,000st)	Charge air press(mmHg)	Difference in delivery(cc)
Full speed position	1,250	34.0~36.0		
	600	27.0~31.0		
	2,250	31.8~35.8		
	2,600	13.2~17.2		
	2,900	Below 5.0		
Switch OFF	315	0		
Idling position	315	5.5~ 9.5		
	500	0		

3. Dimensions

K	3.2~3.4 mm
KF	5.7~5.9 mm
MS	1.5~1.7 mm
BCS	— mm

Control lever angle

α	-2~+6 deg
A	— mm
β	33.0~43.0 deg
B	— mm
γ	— deg
C	— mm

2-5 Solenoid Max.cut-in voltage : 8 V
Test voltage : 12~14 V

INJ. PUMP CALIBRATION DATA

Distributor-type

TEST OIL:
I S O 4113 or
S A E J967d

ENGINE MODEL : C223

Injection pump No: 104649-1310 [NP-VE4/9F2175RNP185]

Pump rotation : clockwise-viewed from drive side

Pre-stroke : - mm

1/3
BOSCH No.9 460 610 109
DKKC No. 104749-1390
Date : 20.Nov.1986 [0]
Company : ISUZU
No. 894114 4380

For Test Condition see
Microfiche No.WP-210(N16)

104749-1390 2/3

1. Setting	Pump speed (rpm)	Settings	Charge air press(mmHg)	Difference in delivery(cc)
1-1 Timing device travel	1,500	4.2~ 4.6 (mm)		
1-2 Supply pump pressure	1,500	5.2~ 5.6 (kg/cm ²)		
1-3 Full load delivery without charge air pressure	1,500	39.9~40.9 (cc/1,000st)		3
Full load delivery with charge air pressure		(cc/1,000st)		
1-4 Idle speed regulation	350	5.5~ 9.5 (cc/1,000st)		2
1-5 Start	100	Above 63 (cc/1,000st)		
1-6 Full-load speed regulation	2,440	10.1~16.1 (cc/1,000st)		4.0
1-7 ACS Adjustment	1,500	Decrease 4.2~ 6.7 (cc/1,000st)	-164±5	
1-8 CSD Adjustment	500~700	Release speed		

2. Test Specifications

2-1 Timing device	N = rpm mm	1,000 1.6~ 2.8	1,500 4.1~ 4.7	2,175 7.0~ 7.9	
2-2 Supply pump	N = rpm kg/cm ²	250 1.6~ 2.2	1,000 3.8~ 4.4	1,500 5.2~ 5.6	2,115 6.6~ 7.2
2-3 Overflow delivery	N = rpm cc/10s	1,000 48~92			

2-4 Fuel injection quantities

Speed control lever position	Pump speed (rpm)	Fuel delivery (cc/1,000st)	Charge air press(mmHg)	Difference in delivery(cc)
Full speed position	1,500	39.4~41.4		
	600	30.7~34.7		
	1,000	33.7~37.7		
	1,500	Decrease 3.5~ 7.4	-164±5	
	2,175	34.6~38.8		
	2,440	9.6~16.6		
2,550	Below 5.5			
Switch OFF	350	0		
Idling position	350	5.5~ 9.5		
	450	Below 3		

3. Dimensions

K	3.2~3.4 mm
KF	5.7~5.9 mm
MS	1.7~1.9 mm
BCS	- mm

Control lever angle

α	21.0~29.0 deg
A	9.5~12.2 mm
β	36.5~46.5 deg
B	11.8~14.9 mm
γ	- deg
C	- mm

2-5 Solenoid Max.cut-in voltage : 8 V
Test voltage : 12~14 V

■ FULL-LOAD FUEL INJECTION QUANTITY AND ACS ADJUSTING PROCEDURE AT ALTITUDE

1) FULL-LOAD FUEL INJECTION QUANTITY ADJUSTMENT

- ① Remove the ACS cover, bellow and adjusting shims.
- ② Perform all adjustments as described in the adjusting specifications, except for ACS adjustment.

2) ACS ADJUSTMENT

- ① Attach the ACS cover, bellows and adjusting shims.
- ② At pump speed of 1500 rpm and referring to the graph below, use the shims to adjust the fuel injection quantity decrease quantity according to altitude.

=====
----- Adjustment limit

----- Inspection limit

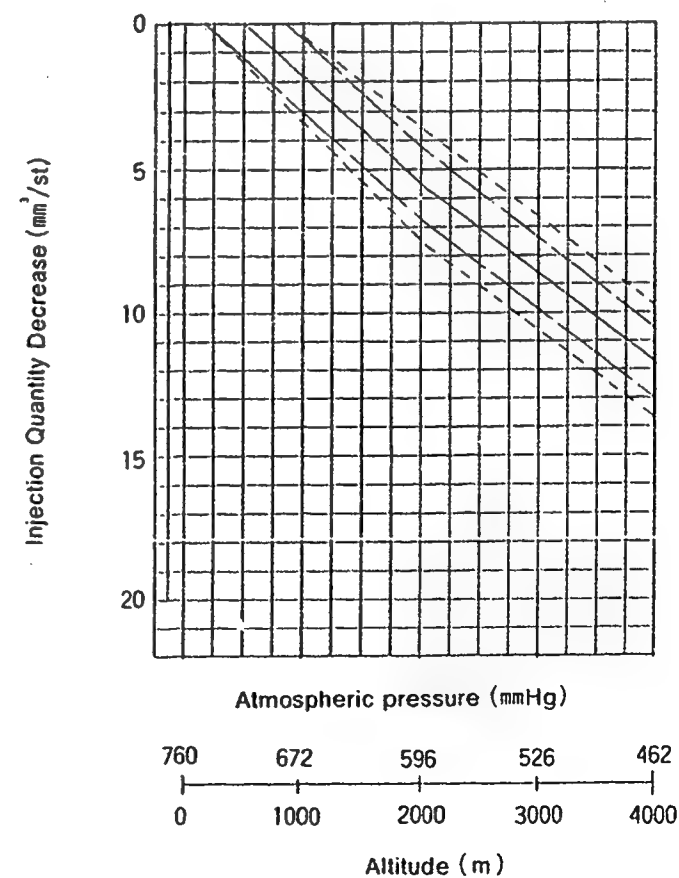

■ CSD Adjustment

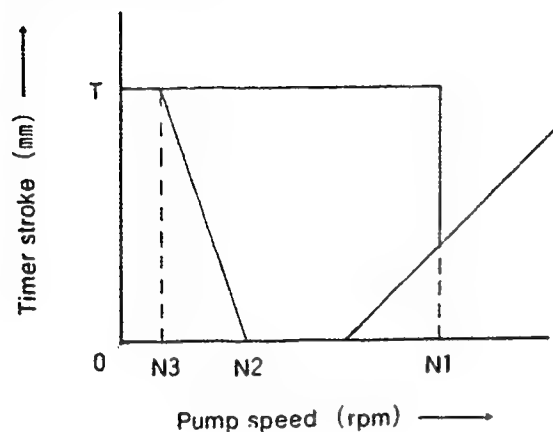

Standard values

N1 (Release speed)	500~700rpm
N2	Less than 225rpm
T	2.7~3.1mm

1) Bleed of air

1. Run the engine at N1 or above.
2. Gradually decrease the pump speed and check the 0 point of the measuring device.
3. Run the pump at a speed midway between N2 and N3.
4. Check that the test oil flows from the CSD overflow.

2) Adjustment

1. Check that the timer stroke is T when the pump is stopped.
2. Adjust the shim thickness so that at the CSD release point the timer piston begins moving in the timer stroke decrease direction at a pump speed of 600 ± 100 rpm.
3. Gradually decrease the pump speed, and check that the CSD begins to operate at speeds less than N2.

Note :

When measuring the release speed, check that there is no leakage from the CSD overflow.

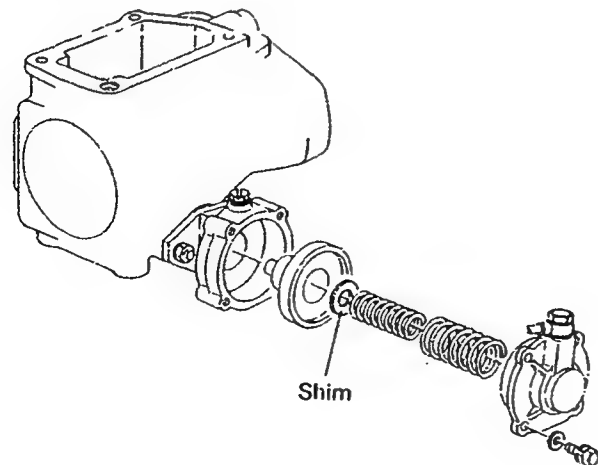

INJ. PUMP CALIBRATION DATA

Distributor-type

TEST OIL:
ISO 4113 or
SAE J967d

ENGINE MODEL : C223

1/3
BOSCH No.9 460 610 110
DKKC No. 104749-1400
Date : 20.Nov.1986
Company : ISUZU
No. 894114 1390

Injection pump No: 104649-1310 (NP-VE4/9F2175RNP185)

Pump rotation : clockwise-viewed from drive side

For Test Condition see
Microfiche No.WP-210(N16)

Pre-stroke : - mm

1. Setting	Pump speed (rpm)	Settings	Charge air press(mmHg)	Difference in delivery(cc)
1-1 Timing device travel	1,500	4.2~ 4.6 (mm)		
1-2 Supply pump pressure	1,500	5.2~ 5.6 (kg/cm ²)		
1-3 Full load delivery without charge air pressure	1,500	39.9~40.9 (cc/1,000st)		3
Full load delivery with charge air pressure		(cc/1,000st)		
1-4 Idle speed regulation	350	5.5~ 9.5 (cc/1,000st)		2
1-5 Start	100	Above 63 (cc/1,000st)		
1-6 Full-load speed regulation	2,440	10.1~16.1 (cc/1,000st)		4.0
1-7 ACS Adjustment	1,500	Decrease 4.2~ 6.7 (cc/1,000st)	-164±5	
1-8 CSD Adjustment	500~700	Release speed		

2. Test Specifications

2-1 Timing device	N = rpm mm	1,000 1.6~ 2.8	1,500 4.1~ 4.7	2,175 7.0~ 7.9
2-2 Supply pump	N = rpm kg/cm ²	250 1.6~ 2.2	1,000 3.8~ 4.4	1,500 5.2~ 5.6 2,115 6.6~ 7.2
2-3 Overflow delivery	N = rpm cc/10s	1,000 48~92		

2-4 Fuel injection quantities

Speed control lever position	Pump speed (rpm)	Fuel delivery (cc/1,000st)	Charge air press(mmHg)	Difference in delivery(cc)
Full speed position	1,500	39.4~41.4		
	600	30.7~34.7		
	1,000	33.7~37.7		
	1,500	Decrease 3.5~ 7.4	-164±5	
	2,175	34.6~38.8		
	2,440	9.6~16.6		
2,550	Below 5.5			
Switch OFF	350	0		
Idling position	350	5.5~ 9.5		
	450	Below 3		

3. Dimensions

K	3.2~3.4 mm
KF	5.7~5.9 mm
MS	1.7~1.9 mm
BCS	- mm

Control lever angle

α	21.0~29.0 deg
A	9.5~12.2 mm
β	36.5~46.5 deg
B	11.8~14.9 mm
Y	- deg
C	- mm

2-5 Solenoid Max.cut-in voltage : 8 V
Test voltage : 12~14 V

FULL-LOAD FUEL INJECTION QUANTITY AND ACS ADJUSTING PROCEDURE AT ALTITUDE

1) FULL-LOAD FUEL INJECTION QUANTITY ADJUSTMENT

- ① Remove the ACS cover, bellows and adjusting shims.
- ② Perform all adjustments as described in the adjusting specifications, except for ACS adjustment.

2) ACS ADJUSTMENT

- ① Attach the ACS cover, bellows and adjusting shims.
- ② At pump speed of 1500 rpm and referring to the graph below, use the shims to adjust the fuel injection quantity decrease quantity according to altitude.

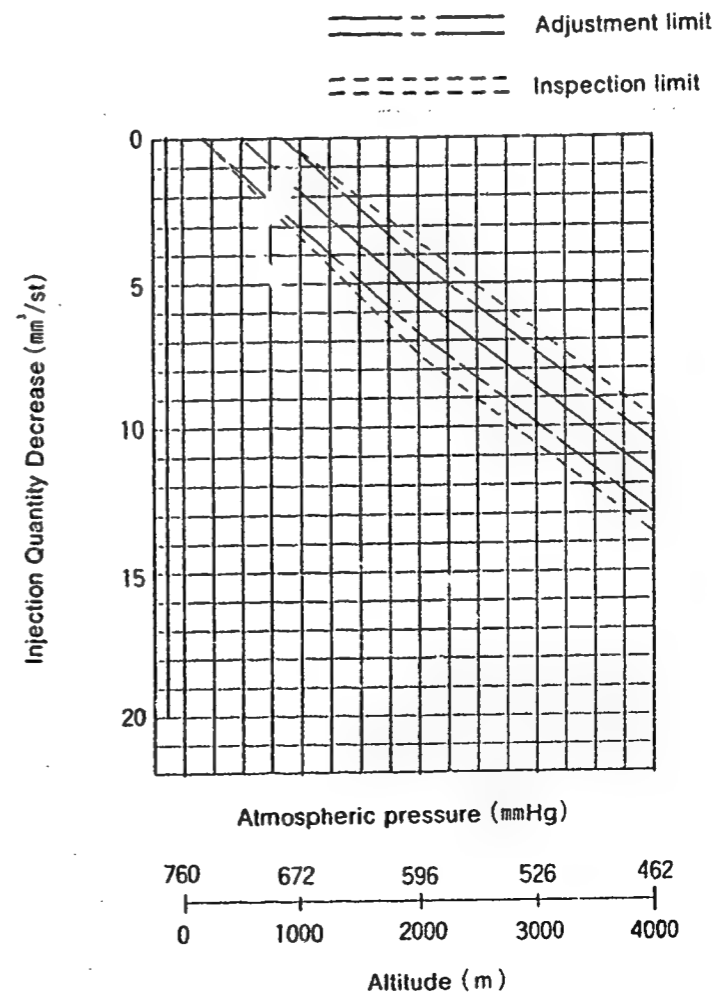

■ CSD Adjustment

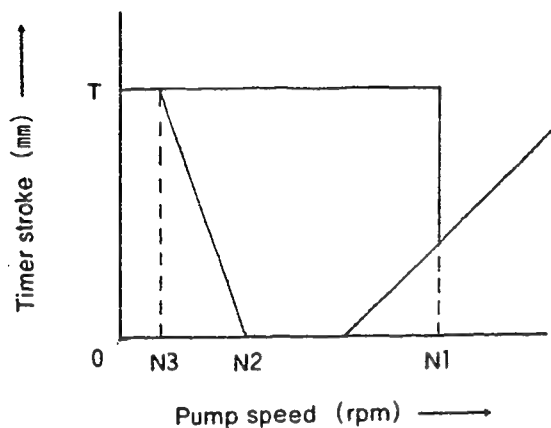

Standard values

N1 (Release speed)	500~700rpm
N2	Less than 225rpm
T	2.7~3.1mm

1) Bleed of air

1. Run the engine at N1 or above.
2. Gradually decrease the pump speed and check the 0 point of the measuring device.
3. Run the pump at a speed midway between N2 and N3.
4. Check that the test oil flows from the CSD overflow.

2) Adjustment

1. Check that the timer stroke is T when the pump is stopped.
2. Adjust the shim thickness so that at the CSD release point the timer piston begins moving in the timer stroke decrease direction at a pump speed of 600 ± 100 rpm.
3. Gradually decrease the pump speed, and check that the CSD begins to operate at speeds less than N2.

Note :

When measuring the release speed, check that there is no leakage from the CSD overflow.

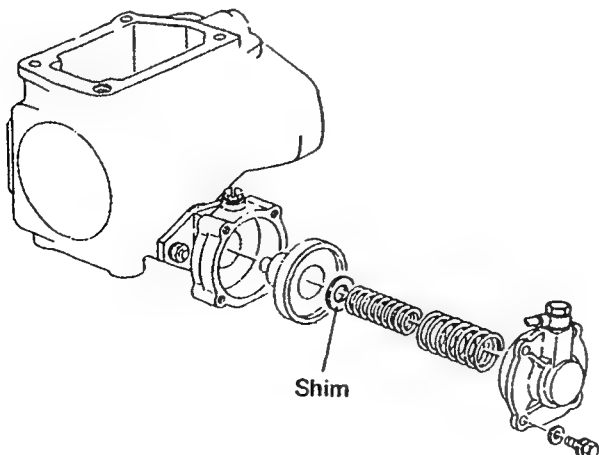

INJ. PUMP CALIBRATION DATA

Distributor-type

TEST OIL:
ISO 4113 or
SAE J967d

ENGINE MODEL : C223

1/3
BOSCH No.9 460 610 111
DKKC No. 104749-1410
Date : 20.Nov.1986 0
Company : ISUZU
No. 894114 4400

Injection pump No: 104649-1310 (NP-VE4/9F2175RNP185)

Pump rotation : clockwise-viewed from drive side

For Test Condition see
Microfiche No.WP-210(N16)

Pre-stroke : — mm

1. Setting	Pump speed (rpm)	Settings	Charge air press(mmHg)	Difference in delivery(cc)
1-1 Timing device travel	1,500	4.2~ 4.6 (mm)		
1-2 Supply pump pressure	1,500	5.2~ 5.6 (kg/cm ²)		
1-3 Full load delivery without charge air pressure	1,500	39.9~40.9 (cc/1,000st)		3
Full load delivery with charge air pressure		(cc/1,000st)		
1-4 Idle speed regulation	350	5.5~ 9.5 (cc/1,000st)		2
1-5 Start	100	Above 63 (cc/1,000st)		
1-6 Full-load speed regulation	2,440	10.1~16.1 (cc/1,000st)		4.0
1-7 ACS Adjustment	1,250	Decrease 3.8~ 6.0 (cc/1,000st)	-164±5	
1-8 CSD Adjustment	500~700	Release speed		

2. Test Specifications

2-1 Timing device	N = rpm mm	1,000 1.6~ 2.8	1,500 4.1~ 4.7	2,175 7.0~ 7.9	
2-2 Supply pump	N = rpm kg/cm ²	250 1.6~ 2.2	1,000 3.8~ 4.4	1,500 5.2~ 5.6	2,175 6.6~ 7.2
2-3 Overflow delivery	N = rpm cc/10s	1,000 48~92			

2-4 Fuel injection quantities

Speed control lever position	Pump speed (rpm)	Fuel delivery (cc/1,000st)	Charge air press(mmHg)	Difference in delivery(cc)
Full speed position	1,500	39.4~41.4	-164±5	
	600	30.7~34.7		
	1,000	33.7~37.7		
	1,500	Decrease 3.5~ 7.4		
	2,175	34.6~38.8		
	2,440	9.6~16.6		
	2,550	Below 5.5		
Switch OFF	350	0		
Idling position	350	5.5~ 9.5		
	450	Below 3		

3. Dimensions

K	3.2~3.4 mm
KF	5.7~5.9 mm
MS	1.7~1.9 mm
BCS	-- mm

Control lever angle

α	21.0~29.0 deg
A	9.5~12.2 mm
β	36.5~46.5 deg
B	11.8~14.9 mm
Y	-- deg
C	-- mm

2-5 Solenoid Max.cut-in voltage : 8 V
Test voltage : 12~14 V

■ FULL-LOAD FUEL INJECTION QUANTITY AND ACS ADJUSTING PROCEDURE AT ALTITUDE

1) FULL-LOAD FUEL INJECTION QUANTITY ADJUSTMENT

- ① Remove the ACS cover, bellow and adjusting shims.
- ② Perform all adjustments as described in the adjusting specifications, except for ACS adjustment.

2) ACS ADJUSTMENT

- ① Attach the ACS cover, bellows and adjusting shims.
- ② At pump speed of 1500 rpm and referring to the graph below, use the shims to adjust the fuel injection quantity decrease quantity according to altitude.

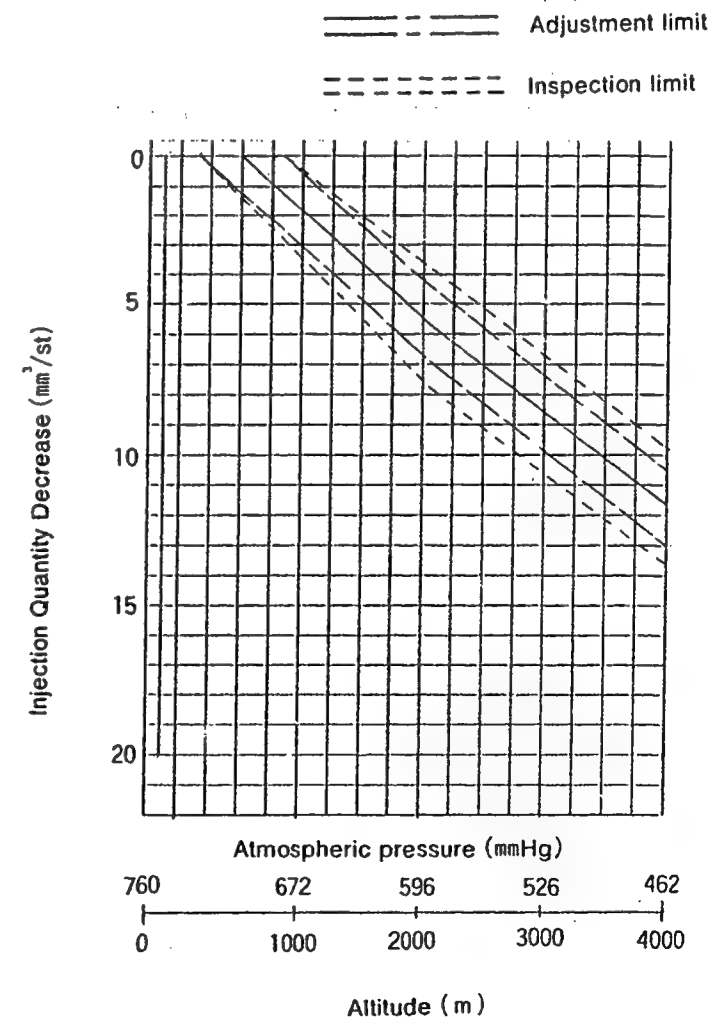

104749-1410 3/3

■ CSD Adjustment

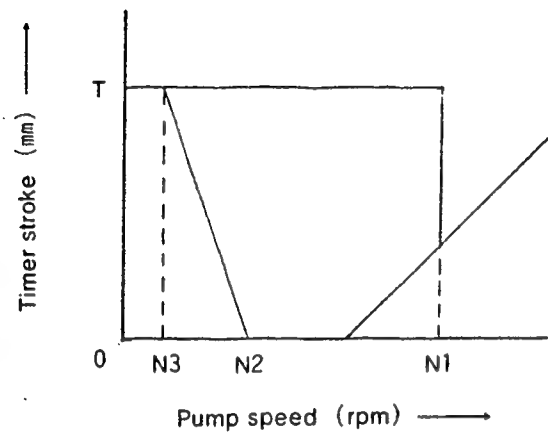

Standard values

N1 (Release speed)	500~700rpm
N2	Less than 225rpm
T	2.7~3.1mm

1) Bleed of air

1. Run the engine at N1 or above.
2. Gradually decrease the pump speed and check the 0 point of the measuring device.
3. Run the pump at a speed midway between N2 and N3.
4. Check that the test oil flows from the CSD overflow.

2) Adjustment

1. Check that the timer stroke is T when the pump is stopped.
2. Adjust the shim thickness so that at the CSD release point the timer piston begins moving in the timer stroke decrease direction at a pump speed of 600 ± 100 rpm.
3. Gradually decrease the pump speed, and check that the CSD begins to operate at speeds less than N2.

Note :

When measuring the release speed, check that there is no leakage from the CSD overflow.

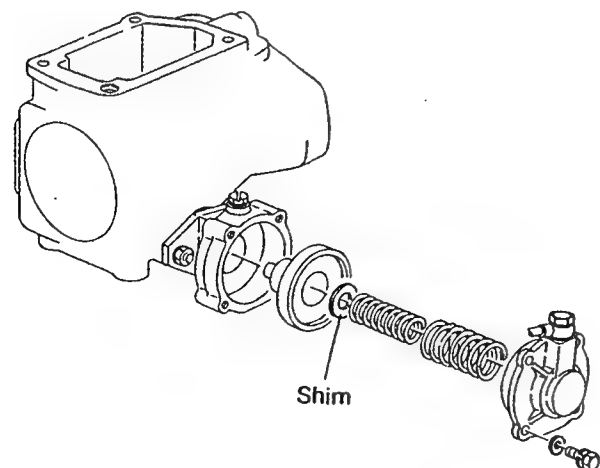

INJ. PUMP CALIBRATION DATA

Distributor-type

TEST OIL:
I S O 4113 or
S A E J967d

ENGINE MODEL : C223

BOSCH No. 9 460 610 112
DKKC No. 104749-1420
Date : 20.Nov.1986
Company : ISUZU
No. 894114 4410

Injection pump No: 104649-1310 [NP-VE4/9F2175RNP185]

Pump rotation : clockwise-viewed from drive side

For Test Condition see
Microfiche No.WP-210(N16)

Pre-stroke : - mm

1. Setting	Pump speed (rpm)	Settings	Charge air press(mmHg)	Difference in delivery(cc)
1-1 Timing device travel	1,500	4.2~ 4.6 (mm)		3
1-2 Supply pump pressure	1,500	5.2~ 5.6 (kg/cm ²)		
1-3 Full load delivery without charge air pressure	1,500	39.9~40.9 (cc/1,000st)		
		(cc/1,000st)		
		Full load delivery with charge air pressure		
1-4 Idle speed regulation	350	5.5~ 9.5 (cc/1,000st)	-164±5	2
1-5 Start	100	Above 63 (cc/1,000st)		
1-6 Full-load speed regulation	2,440	10.1~16.1 (cc/1,000st)		
1-7 ACS Adjustment	1,250	Decrease 3.8~ 6.0 (cm ³ /1,000st)		
1-8 CSD Adjustment	500~700	Release speed		

2. Test Specifications

2-1 Timing device	N = rpm	1,000	1,500	2,175	
	mm	1.6~ 2.8	4.1~ 4.7	7.0~ 7.9	
2-2 Supply pump	N = rpm	250	1,000	1,500	2,175
	kg/cm ²	1.6~ 2.2	3.8~ 4.4	5.2~ 5.6	6.6~ 7.2
2-3 Overflow delivery	N = rpm	1,000			
	cc/10s	48~92			
2-4 Fuel injection quantities	Speed control lever position	Pump speed (rpm)	Fuel delivery (cc/1,000st)	Charge air press(mmHg)	Difference in delivery(cc)
	Full speed position	1,500	39.4~41.4	-164±5	
		600	30.7~34.7		
		1,000	33.7~37.7		
		1,500	Decrease 3.5~ 7.4		
		2,175	34.6~38.8		
		2,440	9.6~16.6		
		2,550	Below 5.5		
	Switch OFF	350	0		
	Idling position	350	5.5~ 9.5		
		450	Below 3		
2-5 Solenoid	Max.cut-in voltage : 8 V				
	Test voltage : 12~14 V				

3. Dimensions

K	3.2~3.4	mm
KF	5.7~5.9	mm
MS	1.7~1.9	mm
BCS	-	mm
Control lever angle		
α	21.0~29.0	deg
A	9.5~12.2	mm
β	36.5~46.5	deg
B	11.8~14.9	mm
γ	-	deg
C	-	mm

FULL-LOAD FUEL INJECTION QUANTITY AND ACS ADJUSTING PROCEDURE AT ALTITUDE

1) FULL-LOAD FUEL INJECTION QUANTITY ADJUSTMENT

- ① Remove the ACS cover, bellow and adjusting shims.
- ② Perform all adjustments as described in the adjusting specifications, except for ACS adjustment.

2) ACS ADJUSTMENT

- ① Attach the ACS cover, bellows and adjusting shims.
- ② At pump speed of 1500 rpm and referring to the graph below, use the shims to adjust the fuel injection quantity decrease quantity according to altitude.

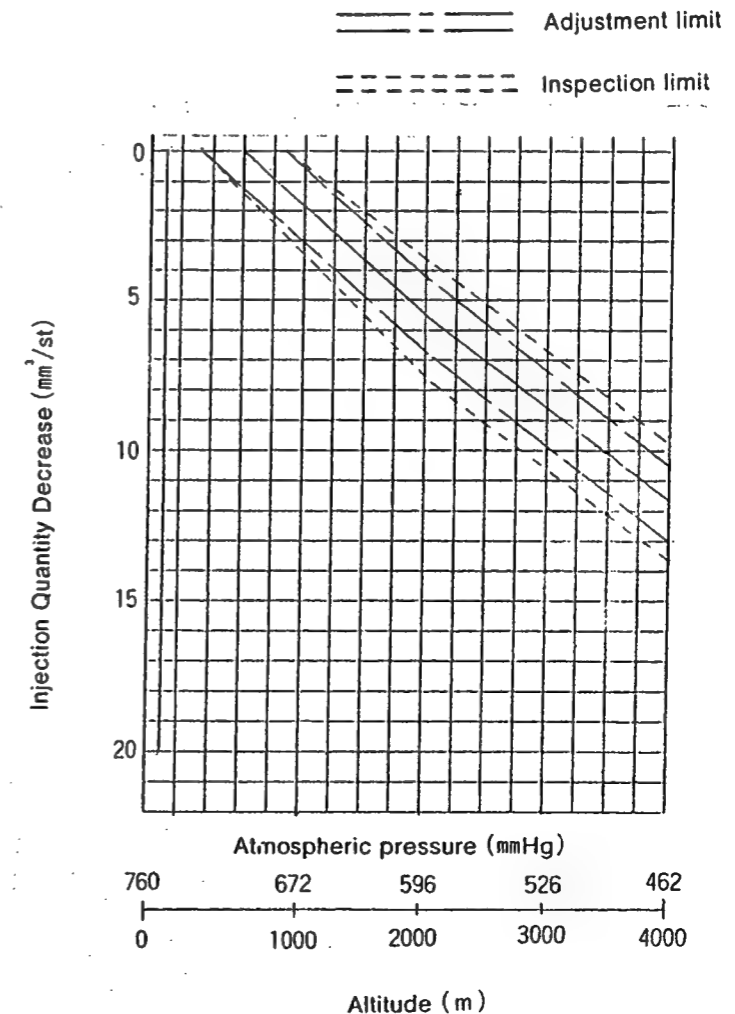

104749-1420 3/3

■ CSD Adjustment

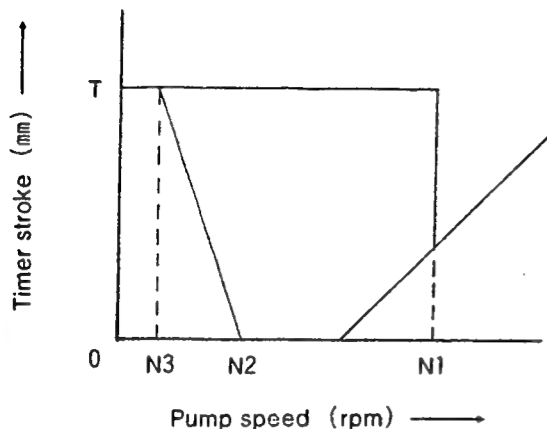

Standard values

- N1 (Release speed) 500~700rpm
- N2 Less than 225rpm
- T 2.7~3.1mm

1) Bleed of air

1. Run the engine at N1 or above.
2. Gradually decrease the pump speed and check the 0 point of the measuring device.
3. Run the pump at a speed midway between N2 and N3.
4. Check that the test oil flows from the CSD overflow.

2) Adjustment

1. Check that the timer stroke is T when the pump is stopped.
2. Adjust the shim thickness so that at the CSD release point the timer piston begins moving in the timer stroke decrease direction at a pump speed of 600 ± 100 rpm.
3. Gradually decrease the pump speed, and check that the CSD begins to operate at speeds less than N2.

Note :

When measuring the release speed, check that there is no leakage from the CSD overflow.

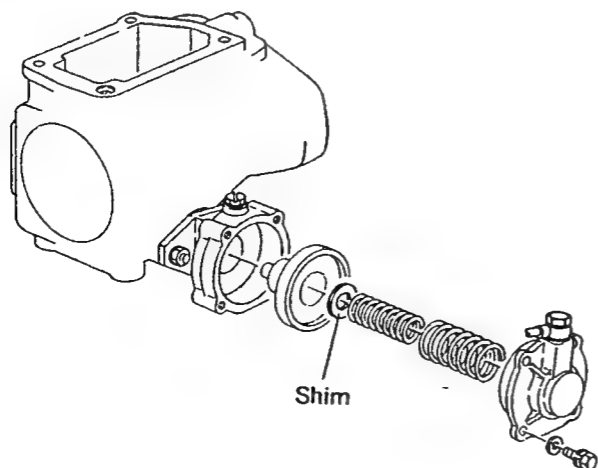

INJ. PUMP CALIBRATION DATA

TEST OIL:
ISO 4113 or
SAE J967d

Distributor-type

ENGINE MODEL : 4FD1

Injection pump No: 104649-1351 [NP-VE4/9F2250RNP220]

Pump rotation : clockwise-viewed from drive side

Pre-stroke : 0.23~0.27 mm

BOSCH No.9 460 610 153

DKKC No. 104749-1491

Date : 20.Nov.1986

Company : ISUZU

No. 894124 0061

For Test Condition see
Microfiche No.WP-210(N16)

1. Setting	Pump speed (rpm)	Settings	Difference in delivery(cc)
1-1 Timing device travel	1,250	3.4~ 3.8 (mm)	
1-2 Supply pump pressure	1,250	4.6~ 5.0 (kg/cm ²)	
1-3 Full load delivery	1,250	37.2~38.2 (cc/1,000st)	3.0
1-4 Idle speed regulation	340	5.5~ 9.5 (cc/1,000st)	2.0
1-5 Start	100	50.0~70.0 (cc/1,000st)	
1-6 Full-load speed regulation	2,600	15.1~17.1 (cc/1,000st)	4.5
1-7			
1-8			

2. Test Specifications

2-1 Timing device	N = rpm	1,250	2,000	2,500
	mm	3.3~ 3.9	6.3~ 7.5	8.6~ 9.4
2-2 Supply pump	N = rpm	1,250	2,000	
	kg/cm ²	4.6~ 5.0	6.2~ 6.8	
2-3 Overflow delivery	N = rpm	1,250		
	cc/10s	55.0~98.0		
2-4 Fuel deliveries				
Speed control lever	Pump speed (rpm)	Fuel delivery (cc/1,000st)		Difference in delivery
End stop	1,250	36.7~38.7		
	600	31.2~35.2		
	1,800	34.2~38.2		
	2,250	33.2~37.2		
	2,600	14.6~17.6		
	2,900	Below 4.5		
Switch OFF	340	0		
Idle stop	340	5.5~ 9.5		
	500	0		
2-5 Solenoid	Voltage : 12 V			

3. Dimensions

K	3.2~3.4 mm
KF	5.7~5.9 mm
MS	1.5~1.7 mm
BCS	— mm

Control lever angle

α	-7.0~ 1.0 deg
A	8.8~11.4 mm
β	32.0~42.0 deg
B	10.2~13.5 mm
Y	— deg
C	— mm

■ CSD Adjustment

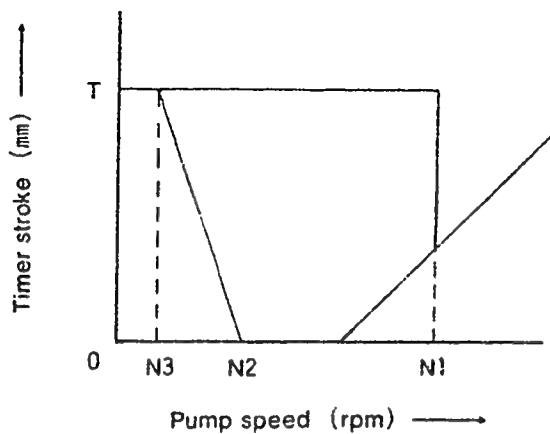

Standard values

N1 (Release speed)	500~700rpm
N2	Less than 225rpm
T	2.7~3.1mm

1) Bleed of air

1. Run the engine at N1 or above.
2. Gradually decrease the pump speed and check the 0 point of the measuring device.
3. Run the pump at a speed midway between N2 and N3.
4. Check that the test oil flows from the CSD overflow.

2) Adjustment

1. Check that the timer stroke is T when the pump is stopped.
2. Adjust the shim thickness so that at the CSD release point the timer piston begins moving in the timer stroke decrease direction at a pump speed of 600 ± 100 rpm.
3. Gradually decrease the pump speed, and check that the CSD begins to operate at speeds less than N2.

Note :

When measuring the release speed, check that there is no leakage from the CSD overflow.

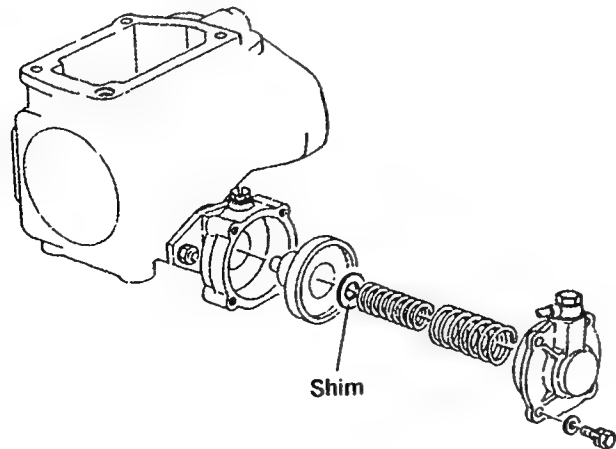

INJ. PUMP CALIBRATION DATA

Distributor-type

TEST OIL:
I S O 4113 or
S A E J967d

ENGINE MODEL : C223

Injection pump No: 104649-1370 (NP-VE4/9F2175RNP224)

Pump rotation : clockwise-viewed from drive side

Pre-strcke : - mm

BOSCH No.9 460 610 119
DKKC-No. 104749-1550
Date : 20.Nov.1986
Company : ISUZU
No. 894124 8470

For Test Condition see
Microfiche No.WP-210(N16)

1. Setting	Pump speed (rpm)	Settings	Charge air press(mmHg)	Difference in delivery(cc)
1-1 Timing device travel	1,500	4.2~ 4.6 (mm)		
1-2 Supply pump pressure	1,500	5.2~ 5.6 (kg/cm ²)		
1-3 Full load delivery without charge air pressure	1,250	35.8~36.8 (cc/1,000st)		3
Full load delivery with charge air pressure		(cc/1,000st)		
1-4 Idle speed regulation	375	5.6~ 9.6 (cc/1,000st)		2
1-5 Start	100	Above 63 (cc/1,000st)		
1-6 Full-load speed regulation	2,550	7.8~13.8 (cc/1,000st)		3.0
1-7 ACS Adjustment	1,250	Decrease 3.8~ 6.0 (cm/1,000st)	-164±5	
1-8 CSD Adjustment	500~700	Release speed		

2. Test Specifications

2-1 Timing device	N = rpm mm	1,000 1.6~ 2.8	1,500 4.1~ 4.7	2,175 7.0~ 7.8	
2-2 Supply pump	N = rpm kg/cm ²	1,000 3.8~ 4.4	1,500 5.2~ 5.6	2,175 6.6~ 7.2	
2-3 Overflow delivery	N = rpm cc/10s	1,000 48~92			
2-4 Fuel injection quantities	Speed control lever position	Pump speed (rpm)	Fuel delivery (cc/1,000st)	Charge air press(mmHg)	Difference in delivery(cc)
Full speed position		1,250	35.3~37.3	-164±5	
		600	29.7~33.7		
		1,250	Decrease 3.1~ 6.7		
		2,157	32.0~36.2		
		2,550	7.3~14.3		
Switch OFF		375	0		
		500	Below 3		
Idling position		375	5.6~ 9.6		
		500	Below 3		
2-5 Solenoid	Max.cut-in voltage : 8 V Test voltage : 12~14 V				

3. Dimensions

K	3.2~3.4 mm
KF	5.7~5.9 mm
MS	1.7~1.9 mm
BCS	- mm

Control lever angle

α	21.0~29.0 deg
A	10.8~13.4 mm
β	37.0~47.0 deg
B	11.9~15.1 mm
γ	- deg
C	- mm

■ FULL-LOAD FUEL INJECTION QUANTITY AND ACS ADJUSTING PROCEDURE AT ALTITUDE

1) FULL-LOAD FUEL INJECTION QUANTITY ADJUSTMENT

- Remove the ACS cover, bellow and adjusting shims.
- Perform all adjustments as described in the adjusting specifications, except for ACS adjustment.

2) ACS ADJUSTMENT

- Attach the ACS cover, bellows and adjusting shims.
- At pump speed of 1250 rpm and referring to the graph below, use the shims to adjust the fuel injection quantity decrease quantity according to altitude.

=====
----- Adjustment limit

----- Inspection limit

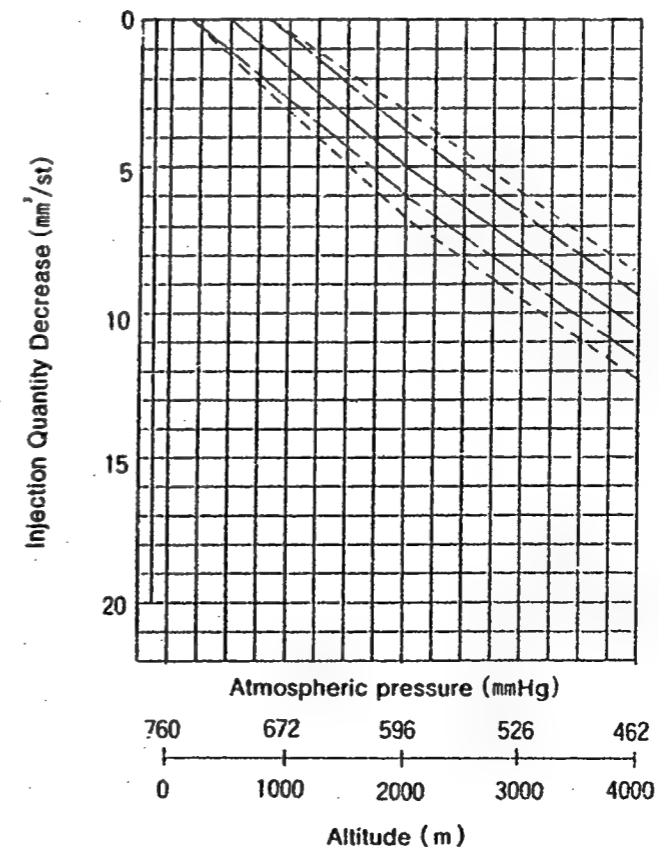

104749-1550 3/3

■ CSD Adjustment

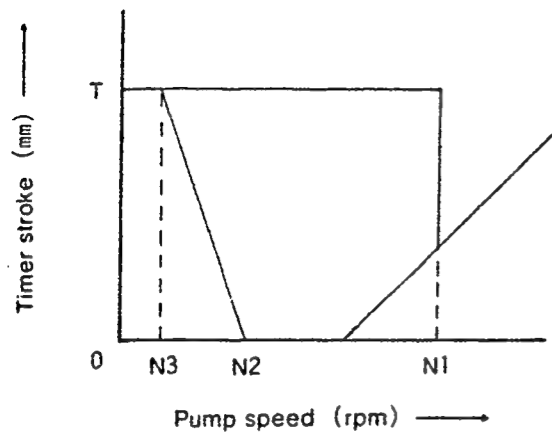

Standard values

N 1 (Release speed)	500~700rpm
N 2	Less than 225rpm
T	2.7~3.1mm

1) Bleed of air

1. Run the engine at N 1 or above.
2. Gradually decrease the pump speed and check the 0 point of the measuring device.
3. Run the pump at a speed midway between N 2 and N 3.
4. Check that the test oil flows from the CSD overflow.

2) Adjustment

1. Check that the timer stroke is T when the pump is stopped.
2. Adjust the shim thickness so that at the CSD release point the timer piston begins moving in the timer stroke decrease direction at a pump speed of 600 ± 100 rpm.
3. Gradually decrease the pump speed, and check that the CSD begins to operate at speeds less than N 2.

Note :

When measuring the release speed, check that there is no leakage from the CSD overflow.

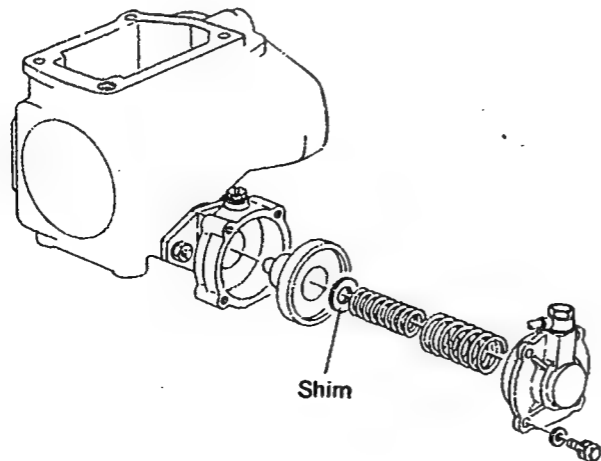

INJ. PUMP CALIBRATION DATA

Distributor-type

TEST OIL:
ISO 4113 or
SAE J967d

ENGINE MODEL : C223

1/3
BOSCH No.9 460 610 120
DKKC No. 104749-1560
Date : 20.Nov.1986
Company : ISUZU
No. 894124 8480

Injection pump No: 104649-1370 [NP-VE4/9F2175RNP224]

Pump rotation : clockwise-viewed from drive side

For Test Condition see
Microfiche No.WP-210(N16)

Pre-stroke : - mm

1. Setting	Pump speed (rpm)	Settings	Charge air press(mmHg)	Difference in delivery(cc)
1-1 Timing device travel	1,500	4.2~ 4.6 (mm)		
1-2 Supply pump pressure	1,500	5.2~ 5.6 (kg/cm ²)		
1-3 Full load delivery without charge air pressure	1,250	35.8~36.8 (cc/1,000st)		3
Full load delivery with charge air pressure		(cc/1,000st)		
1-4 Idle speed regulation	375	5.6~ 9.6 (cc/1,000st)		2
1-5 Start	100	Above 63 (cc/1,000st)		
1-6 Full-load speed regulation	2,550	7.8~13.8 (cc/1,000st)		3.0
1-7 ACS Adjustment	1,250	Decrease 3.8~ 6.0 (cc/1,000st)	-164±5	
1-8 CSD Adjustment	500~700	Release speed		

2. Test Specifications

2-1 Timing device	N = rpm	1,000	1,500	2,175
	mm	1.6~ 2.8	4.1~ 4.7	7.0~ 7.8
2-2 Supply pump	N = rpm	1,000	1,500	2,175
	kg/cm ²	3.8~ 4.4	5.2~ 5.6	6.6~ 7.2
2-3 Overflow delivery	N = rpm	1,000		
	cc/10s	48~92		

Speed control lever position	Pump speed (rpm)	Fuel delivery (cc/1,000st)	Charge air press(mmHg)	Difference in delivery(cc)
Full speed position	1,250	35.3~37.3		
	600	29.7~33.7		
	1,250	Decrease 3.1~ 6.7	-164±5	
	2,157	32.0~36.2		
	2,550	7.3~14.3		
	2,700	Below 3.5		
Switch OFF	375	0		
Idling position	375	5.6~ 9.6		
	500	Below 3		

3. Dimensions

K	3.2~3.4	mm
KF	5.7~5.9	mm
MS	1.7~1.9	mm
BCS	-	mm

Control lever angle

α	21.0~29.0	deg
A	10.8~13.4	mm
β	37.0~47.0	deg
B	11.9~15.1	mm
γ	-	deg
C	-	mm

2-5 Solenoid
Max.cut-in voltage : 8 V
Test voltage : 12~14 V

■ FULL-LOAD FUEL INJECTION QUANTITY AND ACS ADJUSTING PROCEDURE AT ALTITUDE

1) FULL-LOAD FUEL INJECTION QUANTITY ADJUSTMENT

- Remove the ACS cover, bellow and adjusting shims.
- Perform all adjustments as described in the adjusting specifications, except for ACS adjustment.

2) ACS ADJUSTMENT

- Attach the ACS cover, bellows and adjusting shims.
- At pump speed of 1250 rpm and referring to the graph below, use the shims to adjust the fuel injection quantity decrease quantity according to altitude.

=====
----- Adjustment limit
----- Inspection limit

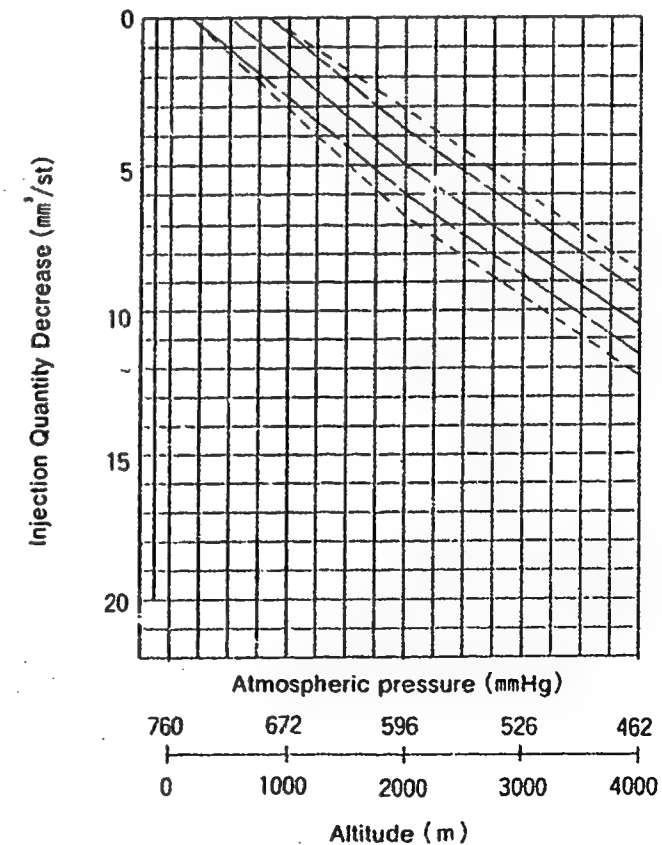

DIESEL KIKI

DIESEL KIKI CO., LTD.
Service Department

3-6-7 SHIBUYA, SHIBUYA-KU, TOKYO 150, JAPAN
Tel. (03) 400-1551 · Fax: (03) 499-4115

■ CSD Adjustment

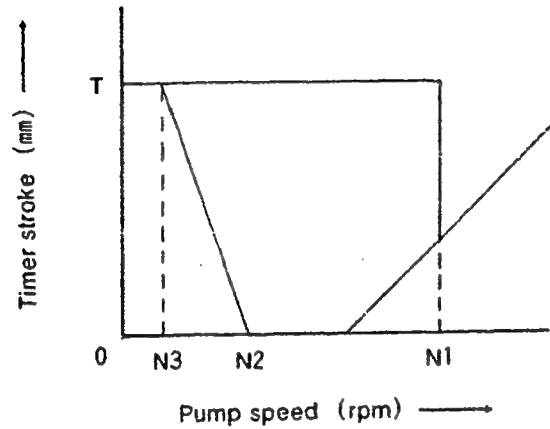

Standard values

N1 (Release speed)	500~700rpm
N2	Less than 225rpm
T	2.7~3.1mm

1) Bleed of air

1. Run the engine at N1 or above.
2. Gradually decrease the pump speed and check the 0 point of the measuring device.
3. Run the pump at a speed midway between N2 and N3.
4. Check that the test oil flows from the CSD overflow.

2) Adjustment

1. Check that the timer stroke is T when the pump is stopped.
2. Adjust the shim thickness so that at the CSD release point the timer piston begins moving in the timer stroke decrease direction at a pump speed of 600 ± 100 rpm.
3. Gradually decrease the pump speed, and check that the CSD begins to operate at speeds less than N2.

Note :

When measuring the release speed, check that there is no leakage from the CSD overflow.

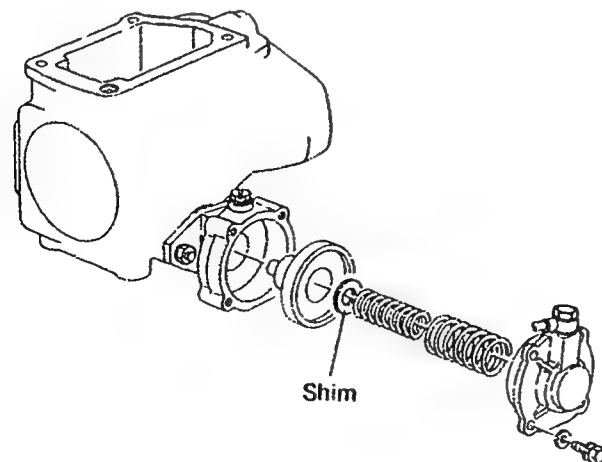

INJ. PUMP CALIBRATION DATA

Distributor-type

TEST OIL:
ISO 4113 or
SAE J967d

ENGINE MODEL : C223

Injection pump No: 104643-1370 [NP-VE4/9F2175RNP224]

Pump rotation : clockwise-viewed from drive side

Pre-stroke : - mm

1/3
BOSCH No.9 460 610 121
DKKC No. 104749-1570
Date : 20.Nov.1986 (Q)
Company : ISUZU
No. 894124 8490

For Test Condition see
Microfiche No.WP-210(N16)

104749-1570 2/3

1. Setting	Pump speed (rpm)	Settings	Charge air press(mmHg)	Difference in delivery(cc)
1-1 Timing device travel	1,500	4.2~ 4.6 (mm)		
1-2 Supply pump pressure	1,500	5.2~ 5.6 (kg/cm ²)		
1-3 Full load delivery without charge air pressure	1,250	35.8~36.8 (cc/1,000st)		3
Full load delivery with charge air pressure		(cc/1,000st)		
1-4 Idle speed regulation	375	5.6~ 9.6 (cc/1,000st)		2
1-5 Start	100	Above 63 (cc/1,000st)		
1-6 Full-load speed regulation	2,550	7.8~13.8 (cc/1,000st)		3.0
1-7 ACS Adjustment	1,250	Decrease 3.8~ 6.0 (cc/1,000st)	-164±5	
1-8 CSD Adjustment	500~700	Release speed		

2. Test Specifications

2-1 Timing device	N = rpm	1,000	1,500	2,175
	mm	1.6~ 2.8	4.1~ 4.7	7.0~ 7.8
2-2 Supply pump	N = rpm	1,000	1,500	2,175
	kg/cm ²	3.8~ 4.4	5.2~ 5.6	6.6~ 7.2
2-3 Overflow delivery	N = rpm	1,000		
	cc/10s	48~92		

2-4 Fuel injection quantities

Speed control lever position	Pump speed (rpm)	Fuel delivery (cc/1,000st)	Charge air press(mmHg)	Difference in delivery(cc)
Full speed position	1,250	35.3~37.3		
	600	29.7~33.7		
	1,250	Decrease 3.1~ 6.7	-164±5	
	2,157	32.0~36.2		
	2,550	7.3~14.3		
	2,700	Below 3.5		
Switch OFF	375	0		
Idling position	375	5.6~ 9.6		
	500	Below 3		

3. Dimensions

K	3.2~3.4	mm
KF	5.7~5.9	mm
MS	1.7~1.9	mm
BCS	-	mm

Control lever angle

α	21.0~29.0	deg
A	10.8~13.4	mm
β	37.0~47.0	deg
B	11.9~15.1	mm
γ	-	deg
C	-	mm

FULL-LOAD FUEL INJECTION QUANTITY AND ACS ADJUSTING PROCEDURE AT ALTITUDE

1) FULL-LOAD FUEL INJECTION QUANTITY ADJUSTMENT

- ① Remove the ACS cover, bellow and adjusting shims.
- ② Perform all adjustments as described in the adjusting specifications, except for ACS adjustment.

2) ACS ADJUSTMENT

- ① Attach the ACS cover, bellows and adjusting shims.
- ② At pump speed of 1250 rpm and referring to the graph below, use the shims to adjust the fuel injection quantity decrease quantity according to altitude.

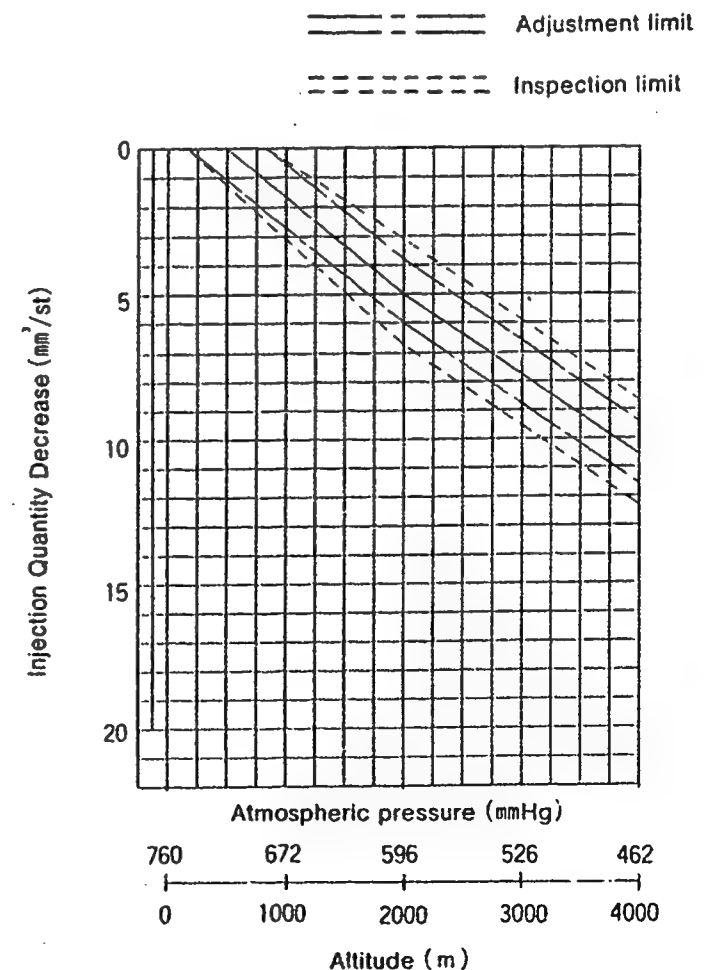

■ CSD Adjustment

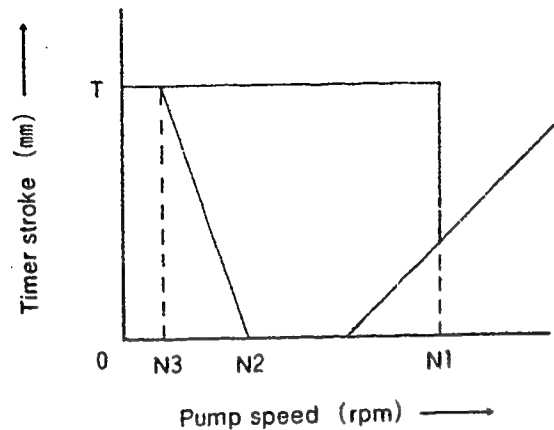

Standard values

N 1 (Release speed)	500~700rpm
N 2	Less than 225rpm
T	2.7~3.1mm

1) Bleed of air

1. Run the engine at N 1 or above.
2. Gradually decrease the pump speed and check the 0 point of the measuring device.
3. Run the pump at a speed midway between N 2 and N 3.
4. Check that the test oil flows from the CSD overflow.

2) Adjustment

1. Check that the timer stroke is T when the pump is stopped.
2. Adjust the shim thickness so that at the CSD release point the timer piston begins moving in the timer stroke decrease direction at a pump speed of 600 ± 100 rpm.
3. Gradually decrease the pump speed, and check that the CSD begins to operate at speeds less than N 2.

Note :

When measuring the release speed, check that there is no leakage from the CSD overflow.

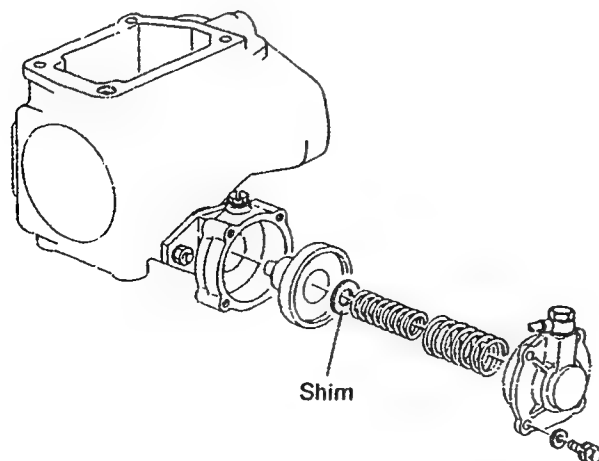

INJ. PUMP CALIBRATION DATA

Distributor-type

ENGINE MODEL : 4FC1D

TEST OIL:
I S O 4113 or
S A E J967d

Injection pump No: 104649-1490 [NP-VE4/9F2250RNP49]

Pump rotation : clockwise-viewed from drive side

Pre-stroke : 0.23~0.27 mm

BOSCH No.9 460 610 098

DKKC No. 104749-1840

Date : 20.Nov.1986

Company : ISUZU

No. 8941298671

For Test Condition see
Microfiche No.WP-210(N16)

1. Setting	Pump speed (rpm)	Settings	Charge air press(mmHg)	Difference in delivery(cc)
1-1 Timing device travel	1,250	2.9~ 3.3 (mm)		
1-2 Supply pump pressure	1,250	4.6~ 5.0 (kg/cm ²)		
1-3 Full load delivery without charge air pressure	1,250	34.5~35.5 (cc/1,000st)		2.5
Full load delivery with charge air pressure		(cc/1,000st)		
1-4 Idle speed regulation	315	5.6~ 9.6 (cc/1,000st)		2.0
1-5 Start	100	52.0~72.0 (cc/1,000st)		
1-6 Full-load speed regulation	2,600	14.5~16.5 (cc/1,000st)		
1-7				
1-8				

2. Test Specifications

2-1 Timing device	N = rpm	1,250	1,800	2,250
	mm	2.8~ 3.4	5.3~ 6.5	7.8~ 8.6
2-2 Supply pump	N = rpm	1,250	2,000	
	kg/cm ²	4.6~ 5.0	6.2~ 6.8	
2-3 Overflow delivery	N = rpm	1,250		
	cc/10s	58.0~102.0		

2-4 Fuel injection quantities

Speed control lever position	Pump speed (rpm)	Fuel delivery (cc/1,000st)	Charge air press(mmHg)	Difference in delivery(cc)
Full speed position	1,250	34.0~36.0		
	600	27.0~31.0		
	2,250	31.8~35.8		
	2,600	13.2~17.2		
	2,900	Below 5		
Switch OFF	315	0		
Idling position	315	5.6~9.6		
	450	0		

2-5 Solenoid Max.cut-in voltage : 8 V
Test voltage : 12~14 V

3. Dimensions

K	3.2~3.4	mm
KF	5.7~5.9	mm
MS	1.5~1.7	mm
BCS	—	mm

Control lever angle

α	-2~+6	deg
A	8.5~11.1	mm
β	33.0~43.0	deg
B	10.6~13.8	mm
γ	—	deg
C	—	mm

INJ. PUMP CALIBRATION DATA

Distributor-type

ENGINE MODEL : 4FC1D

TEST OIL:
I S O 4113 or
S A E J967d

Injection pump No: 104649-1491 [NP-VE4/9F2250RNP49]

Pump rotation : clockwise-viewed from drive side

Pre-stroke : 0.23~0.27 mm

BOSCH No.9 460 610 174

DKKC No. 104749-1841

Date : 20.Nov.1986

Company : ISUZU

No. 894410 2510

For Test Condition see
Microfiche No.WP-210(N16)

1. Setting	Pump speed (rpm)	Settings	Charge air press(mmHg)	Difference in delivery(cc)
1-1 Timing device travel	1,250	2.9~ 3.3 (mm)		
1-2 Supply pump pressure	1,250	4.6~ 5.0 (kg/cm ²)		
1-3 Full load delivery	1,250	34.5~35.5 (cc/1,000st)		2.5
1-4 Idle speed regulation	315	5.6~ 9.6 (cc/1,000st)		2.0
1-5 Start	100	52.0~72.0 (cc/1,000st)		
1-6 Full-load speed regulation	2,600	14.5~16.5 (cc/1,000st)		
1-7				
1-8				

2. Test Specifications

2-1 Timing device	N = rpm	1,250	1,800	2,250
	mm	2.8~ 3.4	5.3~ 6.5	7.8~ 8.6
2-2 Supply pump	N = rpm	1,250	2,000	
	kg/cm ²	4.6~ 5.0	6.2~ 6.8	
2-3 Overflow delivery	N = rpm	1,250		
	cc/10s	58.0~102.0		

2-4 Fuel deliveries

Speed control lever	Pump speed (rpm)	Fuel delivery (cc/1,000st)	Charge air press(mmHg)	Difference in delivery(cc)
End stop	1,250	34.0~36.0		
	600	27.0~31.0		
	2,250	31.8~35.8		
	2,600	13.2~17.2		
	2,900	Below 5.0		
Switch OFF	315	0		
Idle stop	315	5.6~ 9.6		
	450	0		

2-5 Solenoid Voltage : 12 V

3. Dimensions

K	3.2~3.4	mm
KF	5.7~5.9	mm
MS	1.5~1.7	mm
BCS	—	mm

Control lever angle

α	-2.0~ 6.0	deg
A	8.5~11.1	mm
β	33.0~43.0	deg
B	10.6~13.8	mm
γ	—	deg
C	—	mm

INJ. PUMP CALIBRATION DATA

Distributor-type

TEST OIL:
I S O 4113 or
S A E J967d

ENGINE MODEL : 4FC1D

Injection pump No: 104649-1120 [NP-VE4/9F2250RNP49]

BOSCH No.9 460 610 175

DKKC No. 104749-1990

Date : 20.Nov.1986 Q

Company : ISUZU

No. 894144 8640

Pump rotation : clockwise-viewed from drive side

For Test Condition see
Microfiche No.WP-210(N16)

Pre-stroke : 0.23~0.27 mm

1. Setting	Pump speed (rpm)	Settings	Charge air press(mmHg)	Difference in delivery(cc)
1-1 Timing device travel	1,250	2.4~ 2.8 (mm)		
1-2 Supply pump pressure	1,250	4.6~ 5.0 (kg/cm ²)		
1-3 Full load delivery without charge air pressure	1,250	32.0~33.0 (cc/1,000st)		2.5
Full load delivery with charge air pressure		(cc/1,000st)		
1-4 Idle speed regulation	315	5.5~ 9.5 (cc/1,000st)		2.0
1-5 Start	100	52.0~72.0 (cc/1,000st)		
1-6 Full-load speed regulation	2,600	14.2~16.2 (cc/1,000st)		
1-7				
1-8				

2. Test Specifications

2-1 Timing device	N = rpm	1,250	2,000	2,500	
	mm	2.3~ 2.9	4.9~ 6.1	6.9~ 7.8	
2-2 Supply pump	N = rpm	1,250	2,000		
	kg/cm ²	4.6~ 5.0	6.2~ 6.8		
2-3 Overflow delivery	N = rpm	1,250			
	cc/10s	58.0~102			
2-4 Fuel injection quantities					
Speed control lever position	Pump speed (rpm)	Fuel delivery (cc/1,000st)	Charge air press(mmHg)	Difference in delivery(cc)	
Full speed position	1,250	31.5~33.5			
	600	24.5~28.5			
	2,250	29.4~33.6			
	2,600	13.2~17.2			
	2,900	Below 5			
Switch OFF	315	0			
Idling position	315	5.5~9.5			
	500	0			
2-5 Solenoid		Max.cut-in voltage : 8 V			
		Test voltage : 12~14 V			

3. Dimensions

K	3.2~3.4	mm
KF	5.7~5.9	mm
MS	1.5~1.7	mm
BCS	-	mm

Control lever angle

α	-2~+6	deg
A	-	mm
β	33.0~43.0	deg
B	-	mm
γ	-	deg
C	-	mm

Prüfwerte Verteiler- Einspritzpumpen

PRÜF ÖL:
I S O 4113 od
S A E J967d

MOTOR : LD20

BOSCH Nr. 9 460 610 128

DKKC Nr. 104749-2082

Datum : 20.Nov.1986 1

Firma : NISSAN

Nr. 16700 G4100

104749-2082

Einspritzpumpe Nr. 104649-2062 [NP-VE4/9F2200RNP192]

Dreh-richtung von : Rechts seite des Antrieb

Für Prüfbedingung
Siehe M/K WP210(N-16)

Vorhub-Einstellung : - mm

1. Einstellwerte	Drehzahl min ⁻¹	Einstellwerte	Ladedruck bar(mmHg)	Mengenunter- schied(cc)
1-1 Spritzverstellerweg	900	1.1~ 1.7 (mm)		2.5
1-2 Förderpumpendruck	900	2.9~ 3.5 (kg/cm ²)		
1-3 Vollastmenge ohne ladedruck	900	32.5~33.5 (cc/1000Hübe)		
		(cc/1000Hübe)		
1-4 Leerlauf-Abregelung	325	6.7~ 9.7 (cc/1000Hübe)		
1-5 Start	100	Über 52 (cc/1000Hübe)		
1-6 End-Abregelung	2,500	10.2~16.2 (cc/1000Hübe)		
1-7				
1-8				

2. Prüfwerte

2-1 Spritzversteller	N = min ⁻¹ mm	900 1.0~ 1.8	1,800 4.5~ 5.7	2,200 6.7~ 7.8
2-2 Förderpumpe	N = min ⁻¹ kg/cm ²	900 2.8~ 3.6	1,800 4.9~ 5.7	2,200 5.8~ 6.6
2-3 Überlaufmenge	N = min ⁻¹ cc/10s	1,000 36.0~80.0		
2-4 Fördermengen				
Verstellhebellage	Drehzahl min ⁻¹	Fördermenge (cc/1000Hübe)	Ladedruck bar(mmHg)	Mengenunter- schied(cc)
Endanschlag	900	32.0~34.0		
	600	31.2~35.2		
	2,200	31.1~35.1		
	2,500	9.7~16.7		
	2,800	Unter 4		
Abstellung	325	0		
Leerlauf- anschlag	325	6.2~10.2	2.5	
	500	Unter 4		
Teillast	900	5.0~15.0		
2-5 Magnet	Einschaltspannung max. 8 V Prüfspannung 12~14 V			

3. Maße

K	3.2~3.4	mm
KF	5.7~5.9	mm
MS	1.1~1.3	mm
LDA	-	mm
Winkel des Verstellhebel		
α	56.0~60.0	Winkel
YA	8.9~13.2	mm
β	36.0~46.0	Winkel
B	11.0~14.5	mm
γ	10.5~11.5	Winkel
C	6.7~ 7.3	mm

■ Winkelmeßlage des Verstellhebels

Verstellhebelwinkel (α , β , λ) bei Bohrung A messen.

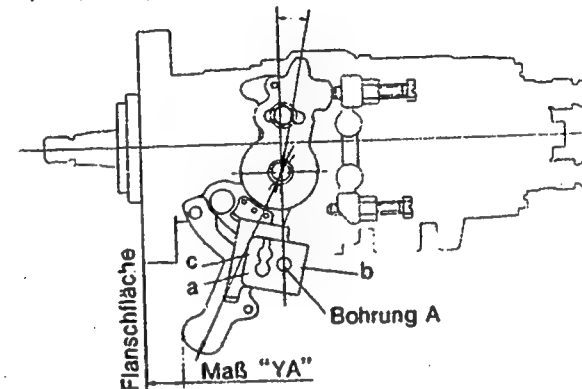

F - 14

INJ. PUMP CALIBRATION DATA

Distributor-type

TEST OIL:
I S O 4113 or
S A E J967d

ENGINE MODEL : LD20E

Injection pump No: 104649-2110 [NP-VE4/9F2100RNP246]

BOSCH No.9 460 610 019

DKKC No. 104749-2130

Date : 20.Nov.1986 0

Company : NISSAN(MISA)

No. 16700 Y9701

Pump rotation : clockwise-viewed from drive side

For Test Condition see
Microfiche No.WP-210(N16)

Pre-stroke : - mm

1. Setting	Pump speed (rpm)	Settings	Charge air press(mmHg)	Difference in delivery(cc)
1-1 Timing device travel	1,250	2.1~ 2.7 (mm)		
1-2 Supply pump pressure	1,250	3.7~ 4.3 (kg/cm ²)		
1-3 Full load delivery without charge air pressure	2,100	28.7~29.7 (cc/1,000st)		2.5
Full load delivery with charge air pressure		(cc/1,000st)		
1-4 Idle speed regulation	325	8.0~11.0 (cc/1,000st)		3.0
1-5 Start	100	Above 52 (cc/1,000st)		
1-6 Full-load speed regulation	2,500	7.0~13.0 (cc/1,000st)		
1-7				
1-8				

2. Test Specifications

2-1 Timing device	N = rpm	1,250	1,800	2,100	
	mm	1.6~ 3.2	4.7~ 6.3	6.5~ 8.1	
2-2 Supply pump	N = rpm				
	kg/cm ²				
2-3 Overflow delivery	N = rpm	1,250			
	cc/10s	42.0~85.0			
2-4 Fuel injection quantities					
Speed control lever position	Pump speed (rpm)	Fuel delivery (cc/1,000st)	Charge air press(mmHg)	Difference in delivery(cc)	
Full speed position	2,100	26.7~31.7		3.5	
	750	24.5~31.5			
	1,250	28.1~35.1			
	2,500	5.5~14.5			
Switch OFF	325	0			
Idling position	325			4.0	
Start quantity	100	Above 50			
2-5 Solenoid	Max.cut-in voltage : 8 V Test voltage : 12~14 V				

3. Dimensions

K	3.2~3.4	mm
KF	5.7~5.9	mm
MS	1.3~1.5	mm
BCS	-	mm

Control lever angle

α	16.0~24.0	deg
A	5.7~10.9	mm
β	32.0~42.0	deg
B	9.5~13.4	mm
γ	-	deg
C	-	mm



DIESEL KIKI

DIESEL KIKI CO., LTD.

Service Department

3-6-7 SHIBUYA, SHIBUYA-KU, TOKYO 150, JAPAN

Tel. (03) 400-1551 · Fax: (03) 499-4115

INJ. PUMP CALIBRATION DATA

TEST OIL:
ISO 4113 or
SAE J967d

Distributor-type

ENGINE MODEL : LD20

Injection pump No: 104649-2140 (NP-VE4/9F2500RNP200)

BOSCH No.9 460 610 097
DKKC No. 104749-2141
Date: 20.Nov.1986
Company: NISSAN
No. 16700 05E20

1/4

Pump rotation : clockwise-viewed from drive side

For Test Condition see
Microfiche No.WP-210(N16)

Pre-stroke : - mm

1. Setting	Pump speed (rpm)	Settings	Difference in delivery(cc)
1-1 Timing device travel	900	2.1~ 2.7 (mm)	2.5
1-2 Supply pump pressure	900	2.9~ 3.5 (kg/cm ²)	
1-3 Full load delivery	900	32.5~33.5 (cc/1,000st)	
1-4 Idle speed regulation	325	6.7~ 9.7 (cc/1,000st)	
1-5 Start	100	40.0~50.0 (cc/1,000st)	
1-6 Full-load speed regulation	2,700	7.2~13.2 (cc/1,000st)	
1-7 Load Timer Adjustment	900	1.2~ 1.8 (mm) (9.0~11.0 cc/1,000st)	
1-8			

2. Test Specifications

2-1 Timing device	N = rpm	900	1,800	2,300
	mm	2.0~ 2.8	6.4~ 7.6	8.1~ 9.0
2-2 Supply pump	N = rpm	900	1,800	2,300
	kg/cm ²	2.8~ 3.6	4.9~ 5.7	6.2~ 7.0
2-3 Overflow delivery	N = rpm	900		
	cc/10s	35.0~79.0		

2-4 Fuel deliveries

Speed control lever	Pump speed (rpm)	Fuel delivery (cc/1,000st)	Difference in delivery
End stop	900	30.8~33.5	2.5
	600	29.3~34.5	
	2,300	29.5~34.7	
	2,700	6.7~13.7	
	2,800	Below 6.0	
Switch OFF	325	0	
Idle stop	325	6.2~10.2	2.5
	500	Below 4.0	
Partial load	900	5.0~15.0	
2-5 Solenoid	Voltage : 12 V		

3. Dimensions

K	3.2~3.4	mm
KF	5.7~5.9	mm
MS	1.1~1.3	mm
BCS	-	mm

Control lever angle

α	21.0~29.0	deg
A	7.6~11.7	mm
β	36.0~46.0	deg
B	11.2~14.6	mm
γ	10.5~11.5	deg
C	5.7~ 6.3	mm

Adjustment of the W-CSD.

- Adjusting timing device advance angle (refer to Fig.1.3.)
By means of the screw ① adjust the timing device advance angle so that the value of timing device travel is that from the graph in fig 3.

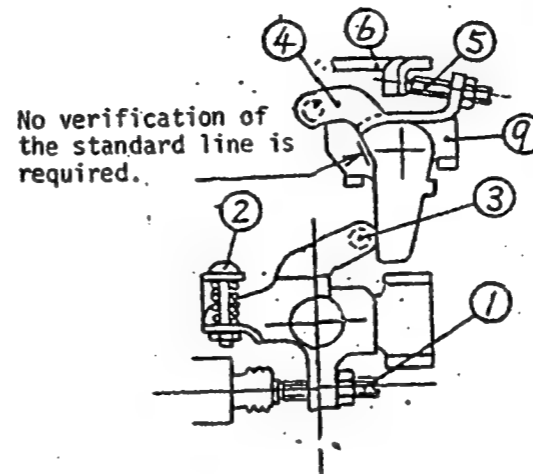

Fig 1

No verification of the standard line is required.

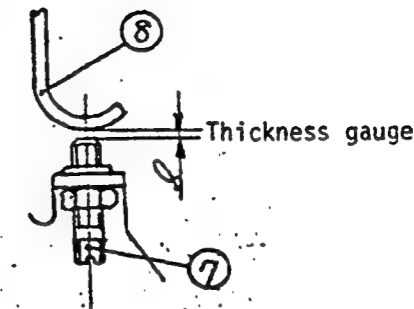
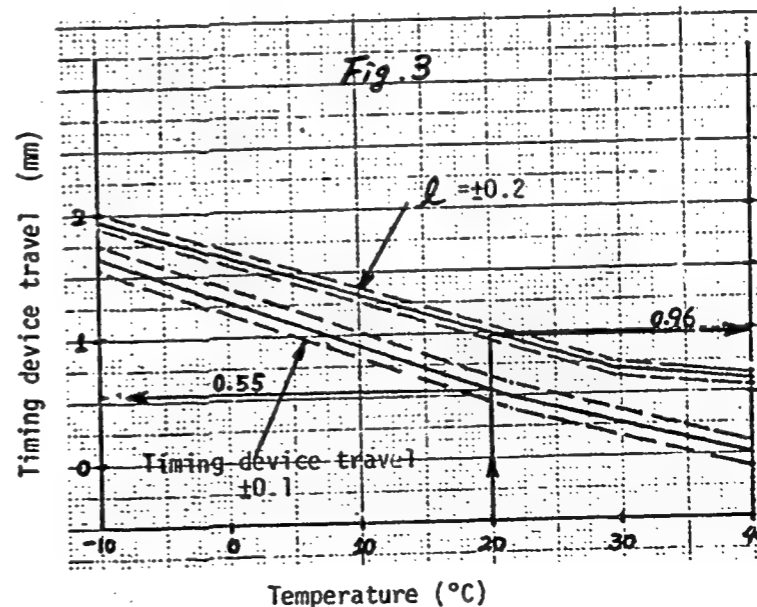

Fig.2



Dimension: *l*
Clearance between control lever and idle stopper bolt

2) Setting intermediate lever position (refer to figs 1 and 2.)

Insert the thickness gauge $l = 0.9 \pm 0.05$ mm between the idle set screw (7) and the control lever (8). When the top edge of the roller of the intermediate lever (4) is positioned at from the top edge of the bracket (6), tighten the screw (5) temporarily so that it contacts the control lever 6.

3) Adjustment of the W-CSD lever (refer to Figs 1 and 2.)

Insert the thickness gauge $l \pm 0.05$ obtained from the graph in Fig 3 between the idle set screw (7) and the control lever (8) and tighten the screw (2) at the position where the roller of the W-CSD lever (3) contacts the intermediate lever (4).

(The temperature of WAX should be less than 30°C during adjustment.)

NOTE: When inserting the thickness gauge allow a gap between the lever (3) and (4) by means of the screw (2) so that the levers from much force.

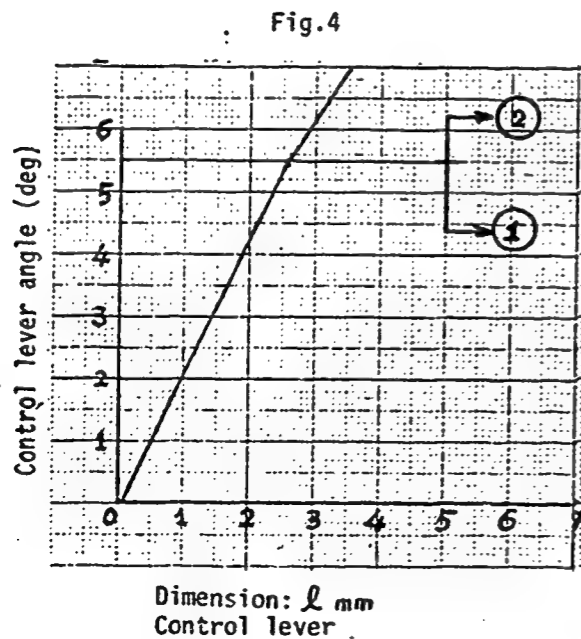

4) W-CSD specification
For control lever angle refer to Fig 4.
Dimension = l

(1) Angle = $2.1246 l$

(2) Angle = $1.6375 l + 1.252$

Dash-Pot Adjustment

Insert the Block gauge $l = 3.8 \pm 0.05$ mm between idle set screw (3) and bracket (4).

Adjust the Dash-Pot adjusting screw (1) to touch the push-rod (5), then tighten the lock-nut (2).

Note: Tightening torque: $T = 0.6$ to 0.9 Kg-m

- A: Check: Alignment between adjusting screw (1) and push rod (5).
- B: Control lever must return to the idle position smoothly.

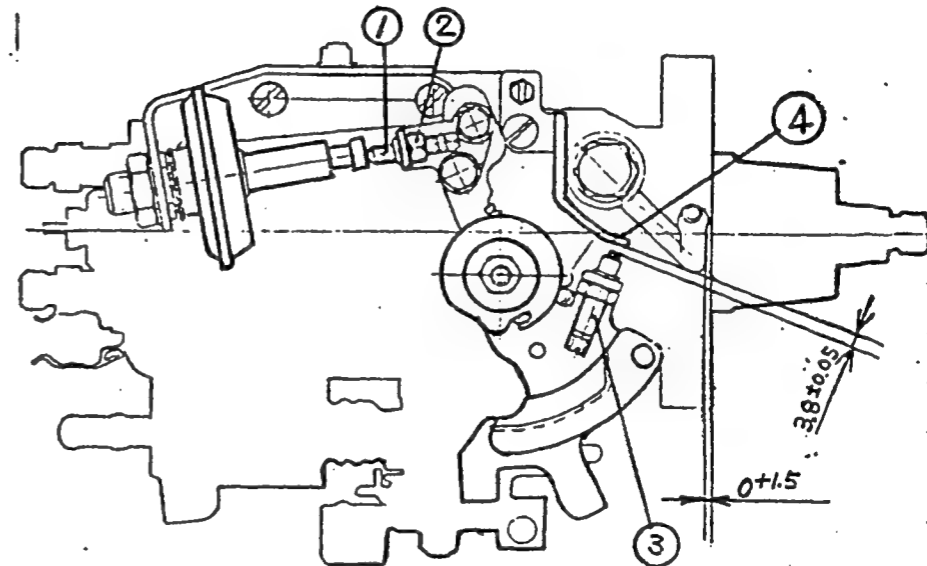

Adjustment of stop lever bolt to obtain adequate fuel delivery for engine starting.

Adjust the bolt shown in below picture and get fuel delivery as specified for engine starting and then fix bolt tightly.
(refer page 1/3)

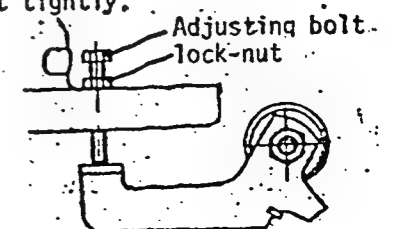

INJ. PUMP CALIBRATION DATA

Distributor-type

TEST OIL:
ISO 4113 or
SAE J967d

ENGINE MODEL : LD20

Injection pump No: 104649-2141 [NP-VE4/9F2500RNP200]

BOSCH No.9 460 610 124

DKKC No. 104749-2142

Date: 20.Nov.1986

Company: NISSAN

No. 16700 05E20

Pump rotation : clockwise-viewed from drive side

For Test Condition see
Microfiche No.WP-210(N16)

Pre-stroke : - mm

1. Setting	Pump speed (rpm)	Settings	Difference in delivery(cc)
1-1 Timing device travel	900	2.1~ 2.7 (mm)	2.5
1-2 Supply pump pressure	900	2.9~ 3.5 (kg/cm ²)	
1-3 Full load delivery	900	32.5~33.5 (cc/1,000st)	
1-4 Idle speed regulation	325	6.7~ 9.7 (cc/1,000st)	
1-5 Start	100	40.0~50.0 (cc/1,000st)	
1-6 Full-load speed regulation	2,700	7.2~13.2 (cc/1,000st)	
1-7 Load Timer Adjustment	900	1.2~ 1.8 (mm) (9.0~11.0 cc/1,000st)	
1-8			

2. Test Specifications

2-1 Timing device	N = rpm	900	1,800	2,300
	mm	2.0~ 2.8	6.4~ 7.6	8.1~ 9.0
2-2 Supply pump	N = rpm	900	1,800	2,300
	kg/cm ²	2.8~ 3.6	4.9~ 5.7	6.2~ 7.0
2-3 Overflow delivery	N = rpm	900		
	cc/10s	35.0~79.0		

2-4 Fuel deliveries

Speed control lever	Pump speed (rpm)	Fuel delivery (cc/1,000st)	Difference in delivery
End stop	900	30.8~33.5	2.5
	600	29.3~34.5	
	2,300	29.5~34.7	
	2,700	6.7~13.7	
	2,800	Below 6.0	
Switch OFF	325	0	
Idle stop	325	6.2~10.2	2.5
	500	Below 4.0	
Partial load	900	5.0~15.0	
2-5 Solenoid	Voltage : 12 V		

3. Dimensions

K	3.2~3.4 mm
KF	5.7~5.9 mm
MS	1.1~1.3 mm
BCS	- mm

Control lever angle

α	21.0~29.0 deg
A	7.6~11.7 mm
β	36.0~46.0 deg
B	11.2~14.6 mm
γ	10.5~11.5 deg
C	5.7~ 6.3 mm

Adjustment of the W-CSD.

- Adjusting timing device advance angle (refer to Fig.1.3.)
By means of the screw ① adjust the timing device advance angle so that the value of timing device travel is that from the graph in fig 3.

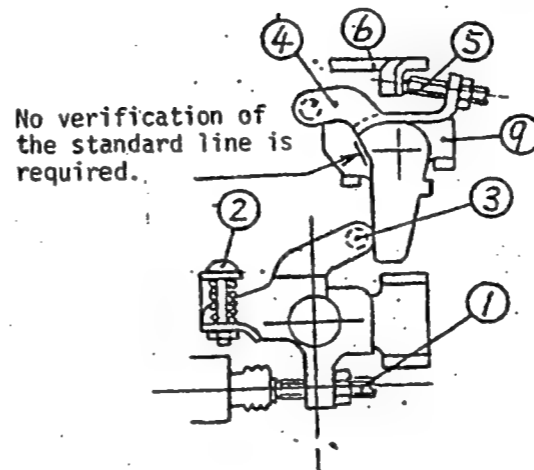

Fig 1

No verification of the standard line is required.

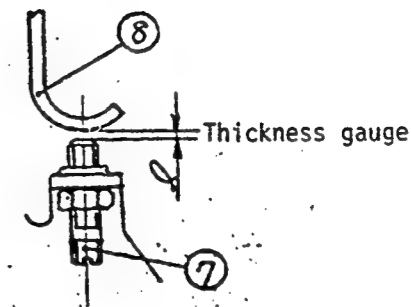
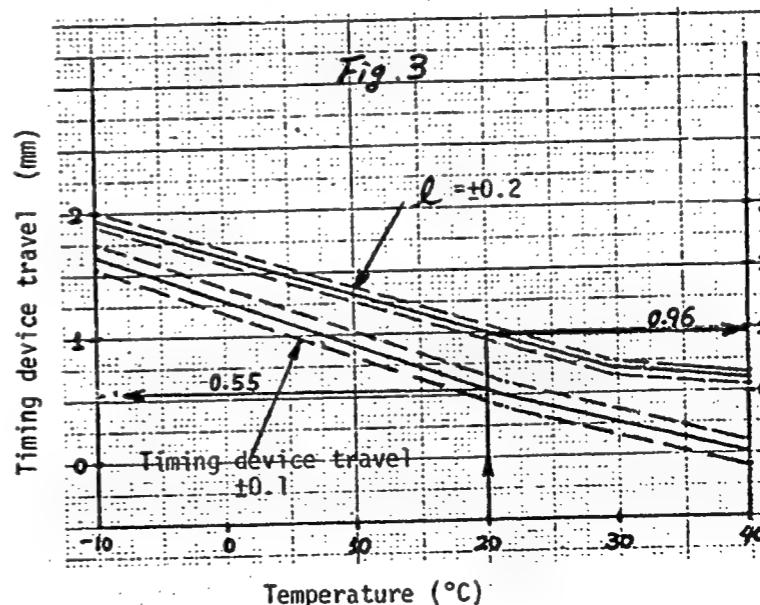

Fig.2



Dimension: l
Clearance between control lever and idle stopper bolt

2) Setting intermediate lever position (refer to figs 1 and 2.)

Insert the thickness gauge $l = 0.9 \pm 0.05$ mm between the idle set screw (7) and the control lever (8). When the top edge of the roller of the intermediate lever (4) is positioned at from the top edge of the bracket (6), tighten the screw (5) temporarily so that it contacts the control lever (6).

3) Adjustment of the W-CSD lever (refer to Figs 1 and 2.)

Insert the thickness gauge $l \pm 0.05$ obtained from the graph in Fig 3 between the idle set screw (7) and the control lever (8) and tighten the screw (2) at the position where the roller of the W-CSD lever (3) contacts the intermediate lever (4).

(The temperature of WAX should be less than 30°C during adjustment.)

NOTE:

When inserting the thickness gauge allow a gap between the lever (3) and (4) by means of the screw (2) so that the levers from much force.

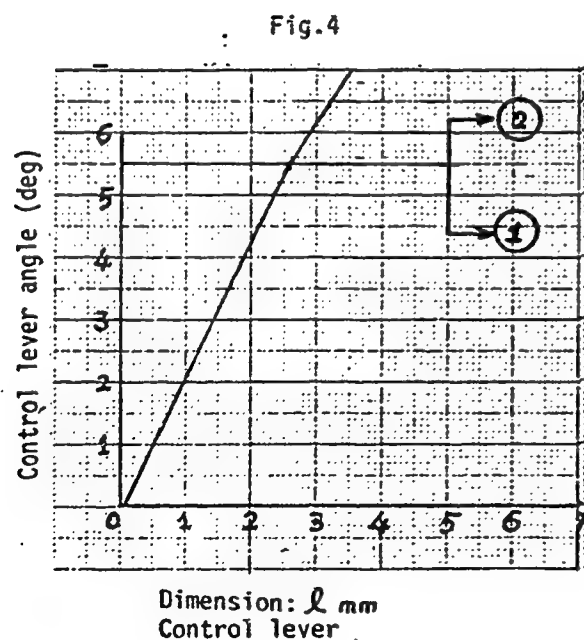

4) W-CSD specification
For control lever angle refer to Fig 4.

Dimension = l

(1) Angle = $2.1246 l$

(2) Angle = $1.6375 l + 1.252$

Dash-Pot Adjustment

Insert the Block gauge $l = 3.8 \pm 0.05$ mm between idle set screw (3) and bracket (4).

Adjust the Dash-Pot adjusting screw (1) to touch the push-rod (5), then tighten the lock-nut (2).

Note: Tightening torque: $T = 0.6$ to 0.9 Kg-m

- A: Check: Alignment between adjusting screw (1) and push rod (5).
- B: Control lever must return to the idle position smoothly.

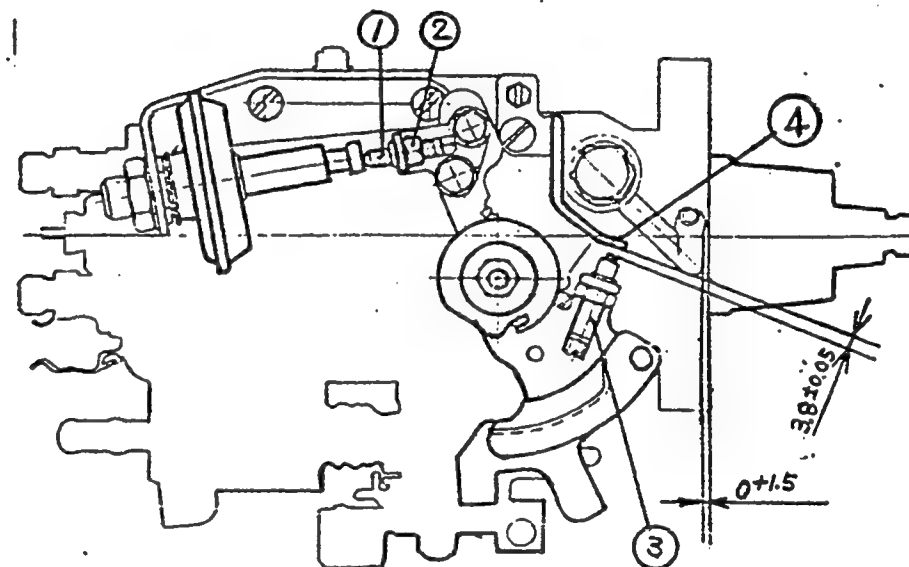

Adjustment of stop lever bolt to obtain adequate fuel delivery for engine starting.

Adjust the bolt shown in below picture and get fuel delivery as specified for engine starting and then fix bolt tightly. (refer page 1/3)

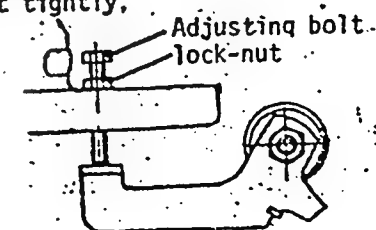

INJ. PUMP CALIBRATION DATA
Distributor-type

TEST OIL:
I S O 4113 or
S A E J967d

ENGINE MODEL : LD20E

Injection pump No: 104649-2150 (NP-VE4/9F2100RNP323)

BOSCH No.9 460 610 093

DKKC No. 104749-2170

Date : 20.Nov.1986 0

Company : NISSAN(MISA)

No. 16700Y9702

Pump rotation : clockwise-viewed from drive side

For Test Condition see
Microfiche No.WP-210(N16)

Pre-stroke : - mm

1. Setting	Pump speed (rpm)	Settings	Charge air press(mmHg)	Difference in delivery(cc)
1-1 Timing device travel	1,250	2.1~ 2.7 (mm)		
1-2 Supply pump pressure	1,250	3.7~ 4.3 (kg/cm ²)		
1-3 Full load delivery without charge air pressure	2,100	28.7~29.7 (cc/1,000st)		2.5
Full load delivery with charge air pressure		(cc/1,000st)		
1-4 Idle speed regulation	325	8.0~11.0 (cc/1,000st)		3.0
1-5 Start	100	Above 52 (cc/1,000st)		
1-6 Full-load speed regulation	2,500	7.0~13.0 (cc/1,000st)		
1-7				
1-8				

2. Test Specifications

2-1 Timing device	N = rpm mm	1,250 1.6~ 3.2	1,800 4.7~ 6.3	2,100 6.5~ 8.1
2-2 Supply pump	N = rpm kg/cm ²			
2-3 Overflow delivery	N = rpm cc/10s	1,250 42.0~35.0		
2-4 Fuel injection quantities				
Speed control lever position	Pump speed (rpm)	Fuel delivery (cc/1,000st)	Charge air press(mmHg)	Difference in delivery(cc)
Full speed position	2,100	26.7~31.7		3.5
	750	24.5~31.5		
	1,250	28.1~35.1		
	2,500	5.5~14.5		
Switch OFF	325	0		
Idling position	325			4.0
	100	Above 50		
2-5 Solenoid	Max.cut-in voltage : 8 V Test voltage : 12~14 V			

3. Dimensions

K	3.2~3.4	mm
KF	5.7~5.9	mm
MS	1.3~1.5	mm
BCS	-	mm
Control lever angle		
α	16.0~24.0	deg
A	5.7~10.9	mm
β	32.0~42.0	deg
B	9.5~13.4	mm
γ	-	deg
C	-	mm

INJ. PUMP CALIBRATION DATA

Distributor-type

TEST OIL:
I S O 4113 or
S A E J967d

ENGINE MODEL : LD20

BOSCH No. 9 460 610 129

DKKC No. 104749-2180

Date : 20.Nov.1986 [1]

Company : NISSAN

No. 16700 G41E0

104749-2180

Injection pump No: 104649-2062 [NP-VE4/9F2200RNP192]

Pump rotation : clockwise-viewed from drive side

For Test Condition see
Microfiche No.WP-210(N16)

Pre-stroke : - mm

1. Setting	Pump speed (rpm)	Settings	Charge air press(mmHg)	Difference in delivery(cc)
1-1 Timing device travel	900	1.1~ 1.7 (mm)		2.5
1-2 Supply pump pressure	900	2.9~ 3.5 (kg/cm ²)		
1-3 Full load delivery without charge air pressure Full load delivery with charge air pressure	900	32.5~33.5 (cc/1,000st) (cc/1,000st)		
1-4 Idle speed regulation	325	6.7~ 9.7 (cc/1,000st)		
1-5 Start	100	Above 52 (cc/1,000st)		
1-6 Full-load speed regulation	2,500	10.2~16.2 (cc/1,000st)		
1-7				
1-8				

2. Test Specifications

2-1 Timing device	N = rpm	900	1,800	2,200
	mm	1.0~ 1.8	4.5~ 5.7	6.7~ 7.8
2-2 Supply pump	N = rpm	900	1,800	2,200
	kg/cm ²	2.8~ 3.6	4.9~ 5.7	5.8~ 6.6
2-3 Overflow delivery	N = rpm	1,000		
	cc/10s	36.0~80.0		

2-4 Fuel injection quantities	Speed control lever position	Pump speed (rpm)	Fuel delivery (cc/1,000st)	Charge air press(mmHg)	Difference in delivery(cc)
	Full speed position	900	32.0~34.0		
		600	31.2~35.2		
		2,200	31.1~35.1		
		2,500	9.7~16.7		
		2,800	Below 4		
Switch OFF		325	0		
Idling position		325	6.2~10.2	2.5	
		500	Below 4		
Partial load		900	5.0~15.0		
2-5 Solenoid	Max.cut-in voltage : 8 V Test voltage : 12~14 V				

3. Dimensions

K	3.2~3.4	mm
KF	5.7~5.9	mm
MS	1.1~1.3	mm
BCS	-	mm

Control lever angle

α	56.0~60.0	deg
YA	8.9~13.2	mm
β	36.0~46.0	deg
B	11.0~14.5	mm
γ	10.5~11.5	deg
C	6.7~ 7.3	mm

Control Lever Angle Measurement Position

Measure the control lever angles (α, β, γ) at hole A.

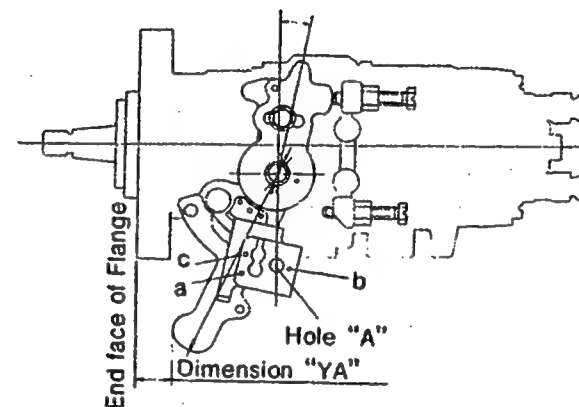

INJ. PUMP CALIBRATION DATA

Distributor-type

ENGINE MODEL : LD20

TEST OIL:
ISO 4113 or
SAE J967d

Injection pump No: 104649-2190 (NP-VE4/9F2500RNP359)

BOSCH No.9 460 610 156
DKKC No. 104749-2190
Date: 20.Nov.1986 0
Company: NISSAN
No. 16700 05E21

104749-2190 2/4

Pump rotation : clockwise-viewed from drive side

Pre-stroke : - mm

For Test Condition see
Microfiche No.WP-210(N16)

1. Setting	Pump speed (rpm)	Settings	Charge air press(mmHg)	Difference in delivery(cc)
1-1 Timing device travel	900	T=1.3~ 1.7 (mm)		
1-2 Supply pump pressure	900	3.2~ 3.8 (kg/cm ²)		
1-3 Full load delivery without charge air pressure	900	32.5~33.5 (cc/1,000st)		2.5
Full load delivery with charge air pressure		(cc/1,000st)		
1-4 Idle speed regulation	350	4.7~ 7.7 (cc/1,000st)		
1-5 Start	100	40.0~50.0 (cc/1,000st)		
1-6 Full-load speed regulation	2,700	10.9~16.9 (cc/1,000st)		
1-7 Load timer adjustment	900	T=0.65±0.2 (mm)		
1-8				

2. Test Specifications

2-1 Timing device	N = rpm	900	1,800	2,300	
	mm	1.2~ 1.8	5.5~ 6.7	7.7~ 8.9	
2-2 Supply pump	N = rpm	900	1,800	2,500	
	kg/cm ²	3.1~ 3.9	5.1~ 5.9	6.8~ 7.6	
2-3 Overflow delivery	N = rpm	900			
	cc/10s	35.0~79.0			
2-4 Fuel deliveries					
Speed control lever	Pump speed (rpm)	Fuel delivery (cc/1,000st)	Charge air press(mmHg)	Difference in delivery	
End stop	2,800	Below 6.0			
	2,700	10.4~17.4			
	2,300	30.6~34.6			
	900	32.0~34.0			
	600	31.2~35.2			
Switch OFF	350	0			
Idle stop	350	4.2~ 8.2		2.5	
	500	Below 4.5			
Partial load	900	4.1~14.1			
2-5 Solenoid	Max.cut-in voltage : 8 V Test voltage : 12~14 V				

3. Dimensions

K	3.2 ~3.4	mm
KF	5.7 ~5.9	mm
MS	1.1 ~1.3	mm
BCS	-	mm

Control lever angle

α	21.0~29.0	deg
A	7.6~11.7	mm
β	39.0~49.0	deg
B	11.9~15.6	mm
γ	10.5~11.5	deg
C	5.5~ 6.1	mm

LOAD TIMER ADJUSTMENT

1) Adjustment

① Fix the control lever in the position satisfying the following conditions.

Boost Pressure : - mmHg
Pump Speed : 900 rpm
Fuel Injection : 17±1 cc/1000st
Quantity

② With the control lever positioned as described in ① above, adjust the governor sleeve so that Timer Stroke conforms to the specified values (page 1/4).

OW-CSD Adjustment

1) Timer stroke adjustment (adjust to the thick line)

1. Calculate the timer stroke from Fig.2 according to the atmospheric temperature at the time of adjustment.
2. Adjust using timer stroke adjusting screw so that the timer stroke is as calculated in Step 1.

2) Intermediate lever position adjustment

1. Insert a block gauge (thickness gauge) of 0.25±0.05mm thickness between the bracket and the idling stopper bolt.
2. Align the intermediate lever with the aligning mark.
3. Adjust the intermediate lever set screw so that the control lever and intermediate lever set screw are in contact, and then fix in position using the locknut.

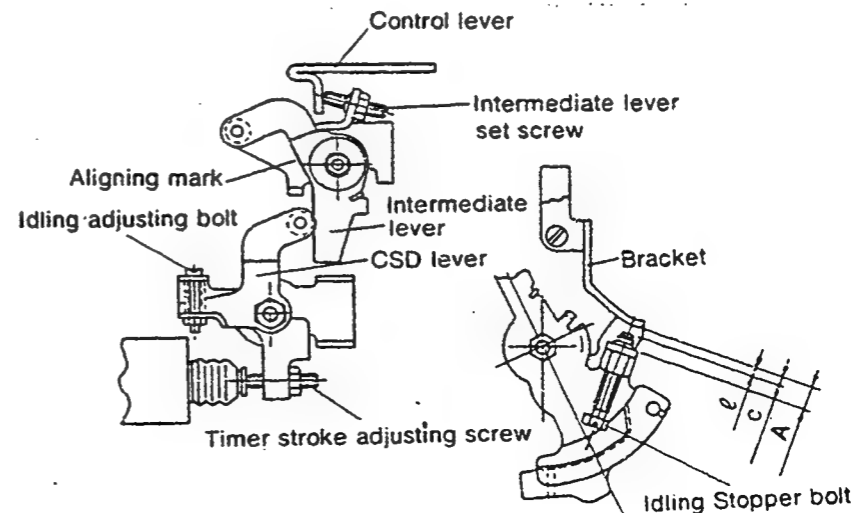

Formula for calculating Fig. 2

Formula for calculating timer stroke: $T = -0.0367t + 1.424$

Formula for calculating control lever and idling stopper bolt gap: $g = -0.095t + 3.6$

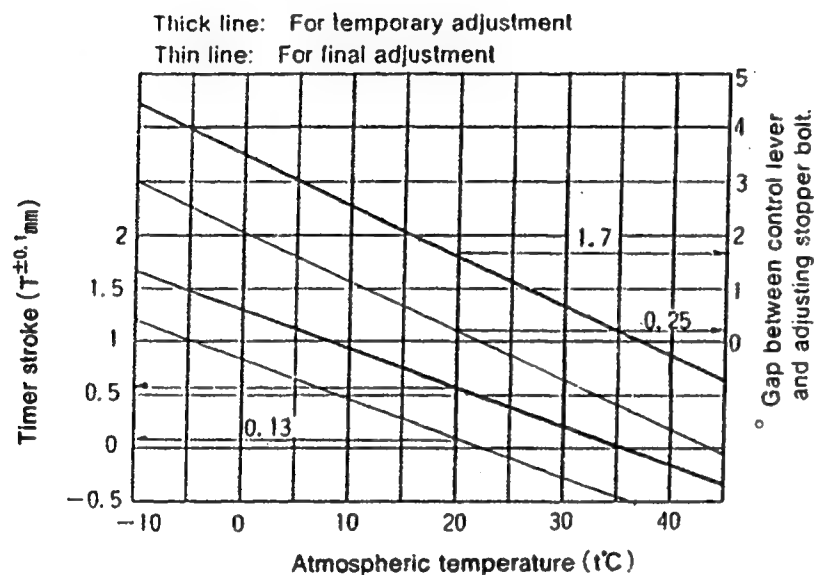

Fig. 2

3) CSD lever adjustment

1. Calculate the block gauge dimension $g \pm 0.05\text{mm}$ from Fig. 2 according to the atmospheric temperature at the time of adjustment.
2. Insert the block gauge (thickness gauge) selected in Step(1) above between the bracket and the idling stopper bolt.
3. Using the idling bolt, adjust so that the CSD lever roller and intermediate lever are in contact.

4) Final adjustment

After completing the adjustment, screw the timer stroke adjusting screw two turns clockwise.
(Move from the temporary adjustment chart to the final adjustment chart.)

※ This W-CSD's timer stroke operations are effective at atmospheric temperatures of 27°C or above.

Therefore, to make adjustment at normal temperatures possible, after adjusting to the substitute characteristics, tighten the time stroke adjusting screw two turns.

Note:

1. The temperature of the wax must be below 30°C when adjusting.
2. When inserting a block gauge (thickness gauge) between the control lever (bracket) and the idling stopper bolt, use the idling adjusting bolt to separate the CSD lever and intermediate lever so that no excessive force is exerted on them.

○ DASH POT ADJUSTMENT

- ① Insert a block gauge (thickness gauge) of thickness 3.8 ± 0.05 in the gap between the control lever and the bracket.
- ② With the control lever positioned as described in ① above, adjust the Dashpot adjusting screw so that the Dashpot adjusting screw and the push rod are in contact. Fix using the nut.

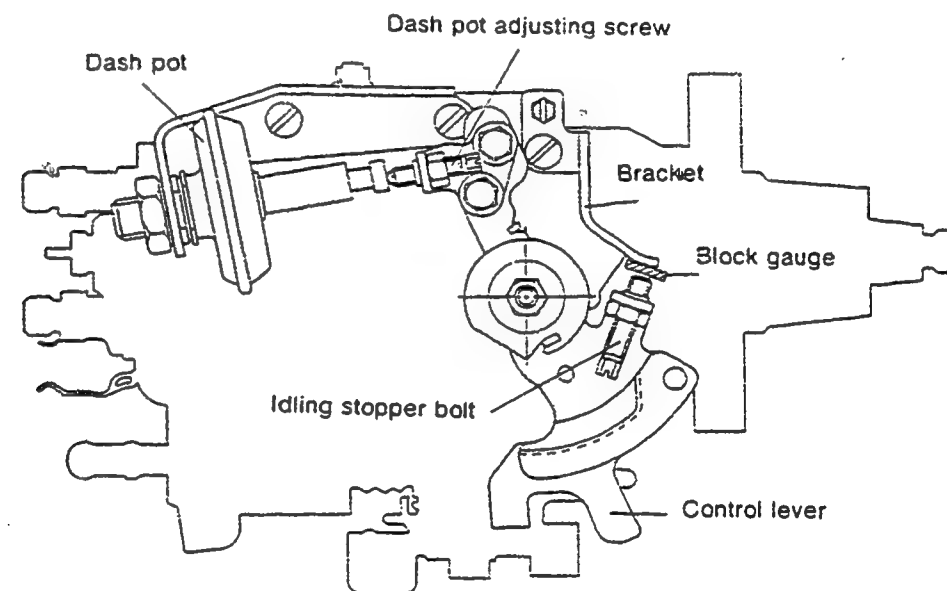

○ Starting Injection Quantity Adjustment

Adjust the starting Injection Quantity (item 1 - 5) using the adjusting bolt (as shown in the figure at below).

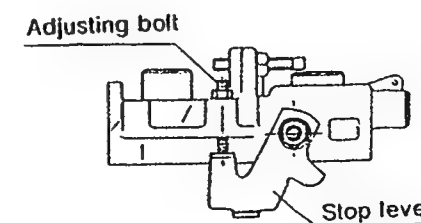

INJ. PUMP CALIBRATION DATA

Distributor-type

BOSCH No. 9 460 610 157

DKKC No. 104749-2210

Date: 20. Nov. 1986 1

Company: NISSAN

No. 16700 G5500

TEST OIL:
I S O 4113 or
S A E J967d

ENGINE MODEL : LD20

Injection pump No: 104649-2210 (NP-VE4/9F2500RNP361)

For Test Condition see
Microfiche No. WP-210(N16)

Pump rotation : clockwise-viewed from drive side

Pre-stroke : - mm

1. Setting	Pump speed (rpm)	Settings	Charge air press(mmHg)	Difference in delivery(cc)
1-1 Timing device travel	900	T=1.3~ 1.7 (mm)		
1-2 Supply pump pressure	900	3.2~ 3.8 (kg/cm ²)		
1-3 Full load delivery without charge air pressure	900	32.5~33.5 (cc/1,000st)		2.5
Full load delivery with charge air pressure		(cc/1,000st)		
1-4 Idle speed regulation	350	4.7~ 7.7 (cc/1,000st)		
1-5 Start	100	40.0~50.0 (cc/1,000st)		
1-6 Full-load speed regulation	2,700	10.9~16.9 (cc/1,000st)		
1-7 Load timer adjustment	900	T=0.65±0.2 (mm)		
1-8				

2. Test Specifications

2-1 Timing device	N = rpm	900	1,800	2,300
	mm	1.2~ 1.8	5.5~ 6.7	7.7~ 8.9
2-2 Supply pump	N = rpm	900	1,800	2,500
	kg/cm ²	3.1~ 3.9	5.1~ 5.9	6.8~ 7.6
2-3 Overflow delivery	N = rpm	900		
	cc/10s	35.0~79.0		

2-4 Fuel deliveries

Speed control lever	Pump speed (rpm)	Fuel delivery (cc/1,000st)	Charge air press(mmHg)	Difference in delivery
End stop	2,800	Below 6.0		
	2,700	10.4~17.4		
	2,300	30.6~34.6		
	900	32.0~34.0		
	600	31.2~35.2		
Switch OFF	350	0		
Idle stop	350	4.2~ 8.2		2.5
	500	Below 4.5		
Partial load	900	4.1~14.1		
2-5 Solenoid	Max.cut-in voltage : 8 V Test voltage : 12~14 V			

3. Dimensions

K	3.2 ~3.4	mm
KF	5.7 ~5.9	mm
MS	1.1 ~1.3	mm
BCS	—	mm

Control lever angle

α	21.0~29.0	deg
A	4.3~ 9.6	mm
β	36.0~46.0	deg
B	10.9~14.6	mm
γ	10.5~11.5	deg
C	6.9~ 7.5	mm

LOAD TIMER ADJUSTMENT

1) Adjustment

① Fix the control lever in the position satisfying the following conditions.

Boost Pressure : — mmHg

Pump Speed : 900 rpm

Fuel Injection : 17±1 cc/1000st

Quantity

② With the control lever positioned as described in ① above, adjust the governor sleeve so that Timer Stroke conforms to the specified values (page 1/3).

Starting Injection Quantity Adjustment

Adjust the starting Injection Quantity (item 1-5) using the adjusting bolt (as shown in the figure at below).

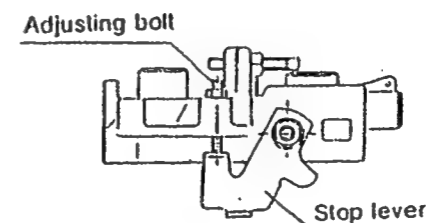

M-CSD Adjustment

1) Fix the intermediate lever adjustment screw in position.

(Adjust with the M-CSD released)

1. Hold control lever (3) in the idling position.
2. Insert a 1.5mm block gauge (thickness gauge) between intermediate lever (4) and intermediate lever bracket (1), and then fix intermediate lever (4) in a position where the adjusting screw (1) is horizontal.
3. Adjust using adjusting screw (1) so that the gap between control lever (3) and adjusting screw (1) is 1 mm, and then fix using the nut.

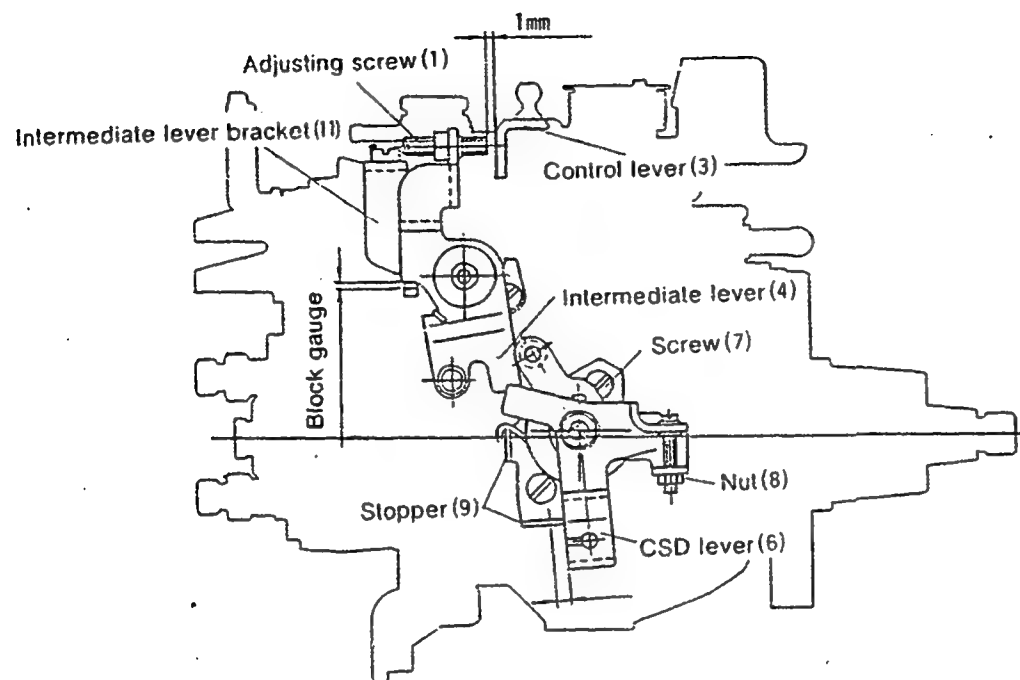

2) Fixing the M-CSD stopper (9)

1. Turn the drive shaft slowly, and fix the drive shaft in a position where a load is applied (the point where the roller in the roller holder contacts the cam surface of the cam disc).
2. Move CSD lever (6) to the advance side.
3. Fix the CSD lever in the position where the ball pin at the tip of the shaft lightly contacts the roller holder (roller holder advance angle "0").
4. Adjust the stopper position so that the gap between CSD lever (6) and stopper (9) is 4.5 mm, and then fix using screw (10).
5. Move the M-CSD lever (6) until it contacts stopper (9), and check that the timer stroke at this point is 1.23 ± 0.2 mm.

3) Screw (7) Adjustment

1. Hold the control lever in the idling position.
2. Adjust using idling adjusting screw (7) so that the gap between control lever (3) and intermediate lever set screw (1) is 1 mm, and then fix using nut (8).
3. Operate CSD lever (6) (move the CSD lever until it contacts stopper (9)).
4. Check that the gap between control lever (3) and the idling stopper bolt is 7.2 ± 0.5 mm.

INJ. PUMP CALIBRATION DATA

Distributor-type

TEST OIL:
I S O 4113 or
S A E J967d

ENGINE MODEL : LD20

BOSCH No.9 460 610 158
DKKC No. 104749-2220
Date : 20.Nov.1986
Company : NISSAN
No. 16700 G5510

Injection pump No: 104649-2220 [NP-VE4/9F2500RNP361]

Pump rotation : clockwise-viewed from drive side
Pre-stroke : — mm

For Test Condition see
Microfiche No.WP-210(N16)

1. Setting	Pump speed (rpm)	Settings	Charge air press(mmHg)	Difference in delivery(cc)
1-1 Timing device travel	900	T=1.3~ 1.7 (mm)		2.5
1-2 Supply pump pressure	900	3.2~ 3.8 (kg/cm ²)		
1-3 Full load delivery without charge air pressure	900	32.5~33.5 (cc/1,000st)		
Full load delivery with charge air pressure		(cc/1,000st)		
1-4 Idle speed regulation	375	5.2~ 8.2 (cc/1,000st)		
1-5 Start	100	40.0~50.0 (cc/1,000st)		
1-6 Full-load speed regulation	2,700	10.9~16.9 (cc/1,000st)		
1-7 Load timer adjustment	900	T-0.65±0.2 (mm)		
1-8				

2. Test Specifications

2-1 Timing device	N = rpm	900	1,800	2,300
	mm	1.2~ 1.8	5.5~ 6.7	7.7~ 8.9
2-2 Supply pump	N = rpm	900	1,800	2,500
	kg/cm ²	3.1~ 3.9	5.1~ 5.9	6.8~ 7.6
2-3 Overflow delivery	N = rpm	900		
	cc/10s	35.0~79.0		
2-4 Fuel deliveries				
Speed control lever	Pump speed (rpm)	Fuel delivery (cc/1,000st)	Charge air press(mmHg)	Difference in delivery
End stop	2,800	Below 6.0		
	2,700	10.4~17.4		
	2,300	30.6~34.6		
	900	32.0~34.0		
	600	31.2~35.2		
Switch OFF	375	0		
Idle stop	375	4.7~ 8.7		2.5
	500	Below 4.5		
Partial load	900	6.3~16.3		
2-5 Solenoid	Max.cut-in voltage : 8 V			
	Test voltage : 12~14 V			

3. Dimensions

K	3.2 ~3.4	mm
KF	5.7 ~5.9	mm
MS	1.1 ~1.3	mm
BCS	—	mm

Control lever angle

α	21.0~29.0	deg
A	4.3~ 9.6	mm
β	34.0~44.0	deg
B	10.2~13.9	mm
Y	10.5~11.5	deg
C	6.9~ 7.5	mm

LOAD TIMER ADJUSTMENT

1) Adjustment

① Fix the control lever in the position satisfying the following conditions.

Boost Pressure : — mmHg
Pump Speed : 900 rpm
Fuel Injection : 17±1 cc/1000st
Quantity

② With the control lever positioned as described in ① above, adjust the governor sleeve so that Timer Stroke conforms to the specified values (page 1/3).

Starting Injection Quantity Adjustment

Adjust the starting Injection Quantity (item 1 - 5) using the adjusting bolt (as shown in the figure at below).

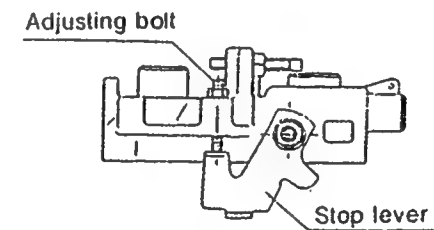

M-CSD Adjustment

1) Fix the intermediate lever adjustment screw in position.

(Adjust with the M-CSD released)

1. Hold control lever (3) in the idling position.
2. Insert a 1.5mm block gauge (thickness gauge) between intermediate lever (4) and intermediate lever bracket (11), and then fix intermediate lever (4) in a position where the adjusting screw (1) is horizontal.
3. Adjust using adjusting screw (1) so that the gap between control lever (3) and adjusting screw (1) is 1 mm, and then fix using the nut.

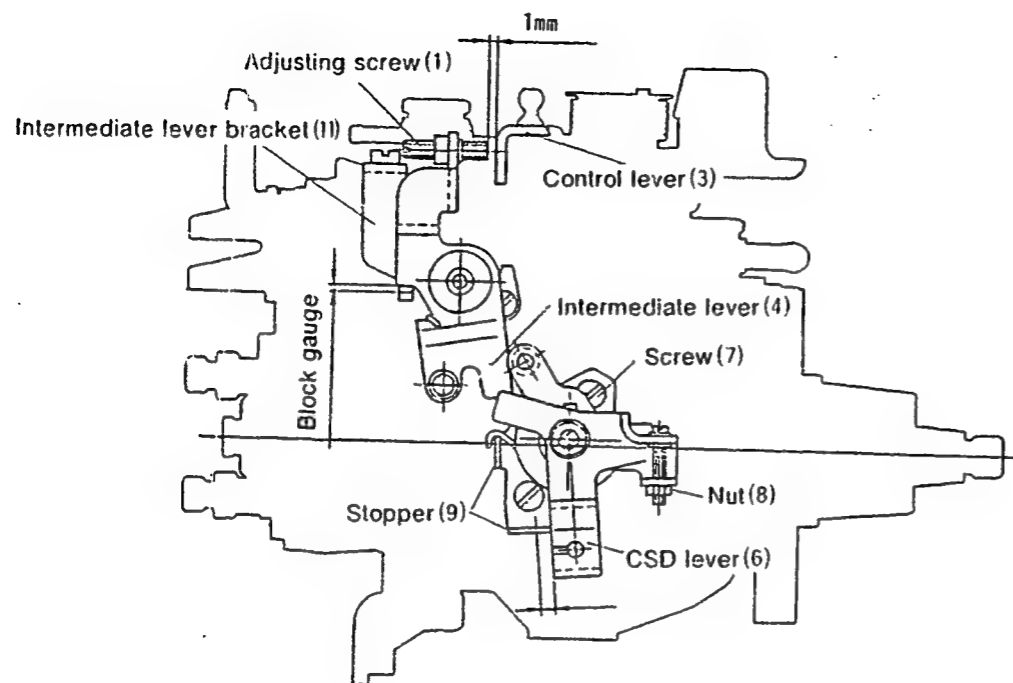

2) Fixing the M-CSD stopper (9)

1. Turn the drive shaft slowly, and fix the drive shaft in a position where a load is applied (the point where the roller in the roller holder contacts the cam surface of the cam disc).
2. Move CSD lever (6) to the advance side.
3. Fix the CSD lever in the position where the ball pin at the tip of the shaft lightly contacts the roller holder (roller holder advance angle "0").
4. Adjust the stopper position so that the gap between CSD lever (6) and stopper (9) is 4.5 mm, and then fix using screw (10).
5. Move the M-CSD lever (6) until it contacts stopper (9), and check that the timer stroke at this point is 1.23 ± 0.2 mm.

3) Screw (7) Adjustment

1. Hold the control lever in the idling position.
2. Adjust using idling adjusting screw (7) so that the gap between control lever (3) and intermediate lever set screw (1) is 1 mm, and then fix using nut (8).
3. Operate CSD lever (6) (move the CSD lever until it contacts stopper (9)).
4. Check that the gap between control lever (3) and the idling stopper bolt is 7.2 ± 0.5 mm.

INJ. PUMP CALIBRATION DATA

TEST OIL:
ISO 4113 or
SAE J967d

Distributor-type

ENGINE MODEL : 4D65-T

BOSCH No.9 460 610 079

DKKC No. 104749-3010

Date : 20.Nov.1986 1

Company : MITSUBISHI

No. MD077258

104749-3010 2/4

Injection pump No: 104649-3010 (NP-VE4/9F2250RNP279)

Pump rotation : clockwise-viewed from drive side

For Test Condition see
Microfiche No.WP-210(N16)

Pre-stroke : - mm

1. Setting	Pump speed (rpm)	Settings	Charge air press(mmHg)	Difference in delivery(cc)
1-1 Timing device travel	1,250	T=3.9~ 4.3 (mm)	580~600	
1-2 Supply pump pressure	1,250	4.5~ 5.1 (kg/cm ²)	580~600	
1-3 Full load delivery without charge air pressure	1,250	46.3~47.3 (cc/1,000st)	580~600	3.0
Full load delivery with charge air pressure	750	40.2~41.2 (cc/1,000st)	0	3.0
1-4 Idle speed regulation	400	5.0~ 8.0 (cc/1,000st)	0	2.0
1-5 Start	100	43.0~63.0 (cc/1,000st)	0	
1-6 Full-load speed regulation	2,750	3.5~ 9.5 (cc/1,000st)	0	2.0
1-7 Load-timer adjustment	1,250	T=0.6±0.2 (mm)		
1-8				

2. Test Specifications

2-1 Timing device	N = rpm	600	1,250	1,750	2,250
	mm	0.7~ 1.9	3.7~ 4.5	5.6~ 6.8	7.6~ 8.8
2-2 Supply pump	N = rpm	600	1,250	2,250	
	kg/cm ²	2.9~ 3.5	4.5~ 5.1	6.8~ 7.4	
2-3 Overflow delivery	N = rpm	1,250			
	cc/10s	48.0~92.0			
2-4 Fuel deliveries	Speed control lever	Pump speed (rpm)	Fuel delivery (cc/1,000st)	Charge air press(mmHg)	Difference in delivery
	End stop	1,250	45.8~47.8	580~600	
		750	39.7~41.7	240~260	
		600	32.7~37.7	0	
		2,250	38.2~43.2	580~600	
		2,750	1.5~11.5	0	
		3,000	Below 3.0	0	
	Switch OFF	400	0	0	
	Idle stop	600	Below 2.0	0	
		400	4.5~ 8.5	0	
2-5 Solenoid	Max.cut-in voltage : 8 V				
	Test voltage : 12~14 V				

3. Dimensions

K	3.2~3.4 mm
KF	5.7~5.9 mm
MS	0.9~1.1 mm
BCS	- mm
Control lever angle	
α	55.0~63.0 deg
A	10.5~16.0 mm
β	36.0~46.0 deg
B	10.5~15.0 mm
γ	- deg
C	- mm

LOAD TIMER ADJUSTMENT

1) Adjustment

① Fix the control lever in the position satisfying the following conditions.

Boost Pressure : - mmHg

Pump Speed : 1250 rpm

Fuel Injection : 33.2±1 cc/1000st

Quantity

② With the control lever position as described in ① above, adjust the governor sleeve so that the Timer Stroke conforms to the specified values (page 1/4)

2) Confirmation of Timer Characteristics

Fix the control lever in the position satisfying the following conditions, and confirm the Timer Stroke.

Control lever position			Specified Values	
Pump speed (rpm)	Fuel Injection Quantity(cc/1000st)	Boost pressure (mmHg)	Timer stroke (mm)	Timer stroke reduction value (mm)
1250	31.7~34.7	-	(3.5)	0.2~1.0
1250	23.7~26.7	-	(2.3~3.5)	(1.2)



DIESEL KIKI

DIESEL KIKI CO., LTD.

3-8-7 SHIBUYA, SHIBUYA-KU, TOKYO 150, JAPAN

Service Department

Tel. (03) 400-1551 Fax: (03) 499-4115

■ DASH POT ADJUSTMENT

- ① Insert a block gauge (thickness gauge) of thickness 7.6 ± 1 in the gap between the control lever and the idling stopper bolt. (control lever angle : $10^\circ \sim 14^\circ$)
- ② With the control lever positioned as described in ① above, adjust the plate position so that the control lever plate and the dash pot push rod are in contact.

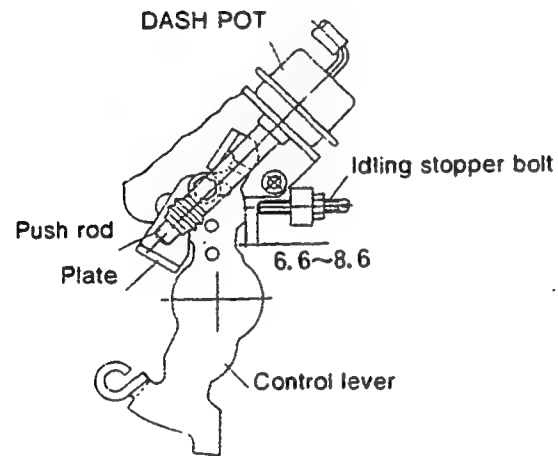

○ Note

- ① At a pump speed of 1250 rpm and boost pressure of 590 mmHg, adjust the Full Load injection quantity after confirming the boost compensator stopper's full stroke.
- ② At a pump speed of 750 rpm and boost pressure of 250 mmHg, adjust the full load fuel injection quantity (40.2~41.2 cc/1000st) using the BCS spring set screw.

■ W-CSD ADJUSTMENT

1) Timer Stroke Adjustment (Refer to Fig 1.2)

- ① Using the graph (Fig 2) , determine the Timer Stroke according to the atmospheric temperature at the time of adjustment.
- ② Adjust using the Timer Stroke adjusting bolt so that the Timer Stroke corresponds to the value determined in note ① above.

2) Fast Idle Adjustment (Refer to Fig 1.2)

- ① Insert a block gauge of 5.3 ± 0.05 mm thickness in the gap between the control lever and the idling stopper bolt.
- ② From Fig 2 determine the dimension of the gap between the idling lever pin and the control lever according to the atmospheric temperature at the time of adjustment.
- ③ Adjust using the fast idle adjusting screw so that the gap corresponds to the value determined in note 2) ② above.

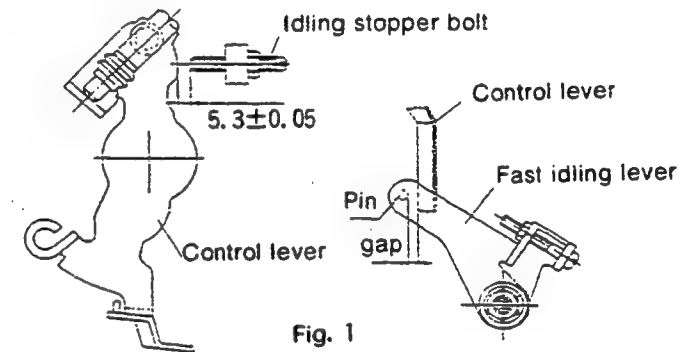

Fig. 1

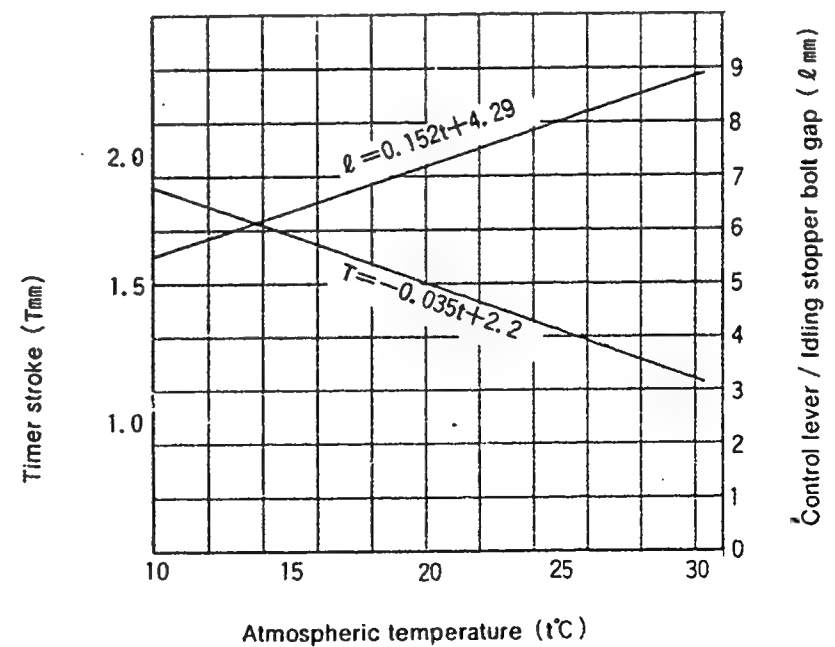

Fig. 2

INJ. PUMP CALIBRATION DATA

TEST OIL:
I S O 4113 or
S A E J967d

Distributor—type

ENGINE MODEL : 4D65—T

Injection pump No: 104649—3010 [NP—VE4/9F2250RNP279]

BOSCH No.9 460 610 080
DKKC No. 104749—3020
Date : 20.Nov.1986 1
Company : MITSUBISHI
No. MD077259

104749—3020 2/4

Pump rotation : clockwise-viewed from drive side

For Test Condition see
Microfiche No.WP-210(N16)

Pre—stroke : — mm

1. Setting	Pump speed (rpm)	Settings	Charge air press(mmHg)	Difference in delivery(cc)
1-1 Timing device travel	1,250	T=3.9~ 4.3 (mm)	580~600	
1-2 Supply pump pressure	1,250	4.5~ 5.1 (kg/cm ²)	580~600	
1-3 Full load delivery without charge air pressure	1,250	46.3~47.3 (cc/1,000st)	580~600	3.0
Full load delivery with charge air pressure	750	40.2~41.2 (cc/1,000st)	0	3.0
1-4 Idle speed regulation	400	5.0~ 8.0 (cc/1,000st)	0	2.0
1-5 Start	100	43.0~63.0 (cc/1,000st)	0	
1-6 Full-load speed regulation	2,750	3.5~ 9.5 (cc/1,000st)	0	2.0
1-7 Load—timer adjustment	1,250	T—0.6±0.2 (mm)		
1-8				

2. Test Specifications

2-1 Timing device	N = rpm mm	600 0.7~ 1.9	1,250 3.7~ 4.5	1,750 5.6~ 6.8	2,250 7.6~ 8.8
2-2 Supply pump	N = rpm kg/cm ²	600 2.9~ 3.5	1,250 4.5~ 5.1	2,250 6.8~ 7.4	
2-3 Overflow delivery	N = rpm cc/10s	1,250 48.0~92.0			

Speed control lever	Pump speed (rpm)	Fuel delivery (cc/1,000st)	Charge air press(mmHg)	Difference in delivery
End stop	1,250	45.8~47.8	580~600	
	750	39.7~41.7	240~260	
	600	32.7~37.7	0	
	2,250	38.2~43.2	580~600	
	2,750	1.5~11.5	0	
	3,000	Below 3.0	0	
Switch OFF	400	0	0	
Idle stop	600	Below 2.0	0	
	400	4.5~ 8.5	0	

2-5 Solenoid Max.cut-in voltage : 8 V
Test voltage : 12~14 V

3. Dimensions

K	3.2~3.4 mm
KF	5.7~5.9 mm
MS	0.9~1.1 mm
BCS	— mm

Control lever angle

α	55.0~63.0 deg
A	10.5~16.0 mm
β	36.0~46.0 deg
B	10.5~15.0 mm
Y	— deg
C	— mm

LOAD TIMER ADJUSTMENT

1) Adjustment

① Fix the control lever in the position satisfying the following conditions.

Boost Pressure : — mmHg
Pump Speed : 1250 rpm
Fuel Injection : 33.2±1 cc/1000st
Quantity

② With the control lever positioned as described in ① above, adjust the governor sleeve so that the Timer Stroke conforms to the specified values (page 1/4)

2) Confirmation of Timer Characteristics

Fix the control lever in the position satisfying the following conditions, and confirm the Timer Stroke.

Control lever position			Specified Values	
Pump speed (rpm)	Fuel Injection Quantity(cc/1000st)	Boost pressure (mmHg)	Timer stroke (mm)	Timer stroke reduction value (mm)
1250	31.7~34.7	—	(3.5)	0.2~1.0
1250	23.7~26.7	—	(2.3~3.5)	(1.2)



DIESEL KIKI

DIESEL KIKI CO., LTD. 3-6-7 SHIBUYA, SHIBUYA-KU, TOKYO 150, JAPAN
Service Department Tel. (03) 400-1551 - Fax: (03) 499-4115

■ DASH POT ADJUSTMENT

- ① Insert a block gauge (thickness gauge) of thickness 7.6 ± 1 in the gap between the control lever and the idling stopper bolt. (control lever angle : $10^\circ \sim 14^\circ$)
- ② With the control lever positioned as described in ① above, adjust the plate position so that the control lever plate and the dash pot push rod are in contact.

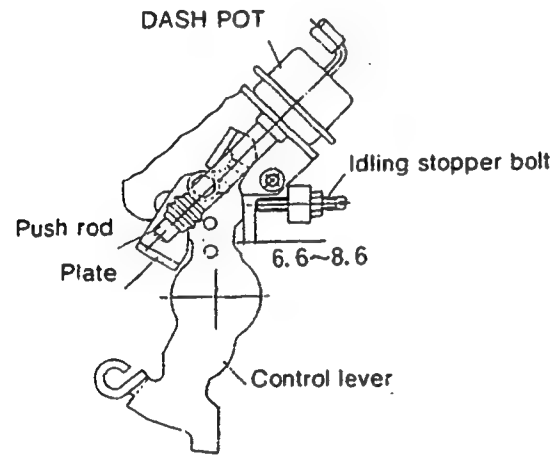

○ Note

- ① At a pump speed of 1250 rpm and boost pressure of 590 mmHg, adjust the Full Load injection quantity after confirming the boost compensator stoppre's full stroke.
- ② At a pump speed of 750 rpm and boost pressure of 250 mmHg, adjust the full load fuel injection quantity ($40.2 \sim 41.2$ cc/1000st) using the BCS spring set screw.

■ W-CSD ADJUSTMENT

1) Timer Stroke Adjustment (Refer to Fig 1.2)

- ① Using the graph (Fig 2) , determine the Timer Stroke according to the atmospheric temperature at the time of adjustment.
- ② Adjust using the Timer Stroke adjusting bolt so that the Timer Stroke corresponds to the value determined in note ① above.

2) Fast Idle Adjustment (Refer to Fig 1.2)

- ① Insert a block gauge of 5.3 ± 0.05 mm thickness in the gap between the control lever and the idling stopper bolt.
- ② From Fig 2 determine the dimension of the gap between the idling lever pin and the control lever according to the atmospheric temperature at the time of adjustment.
- ③ Adjust using the fast idle adjusting screw so that the gap corresponds to the value determined in note 2) ② above.

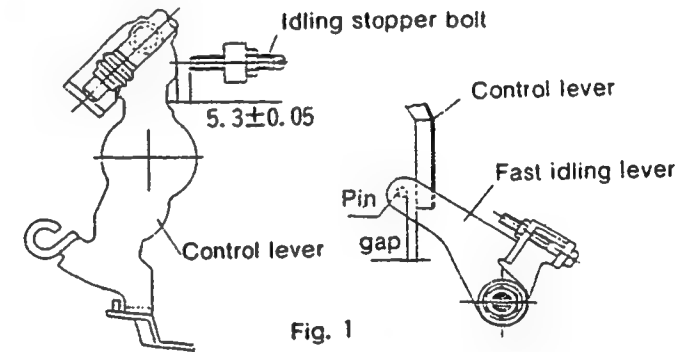

Fig. 1

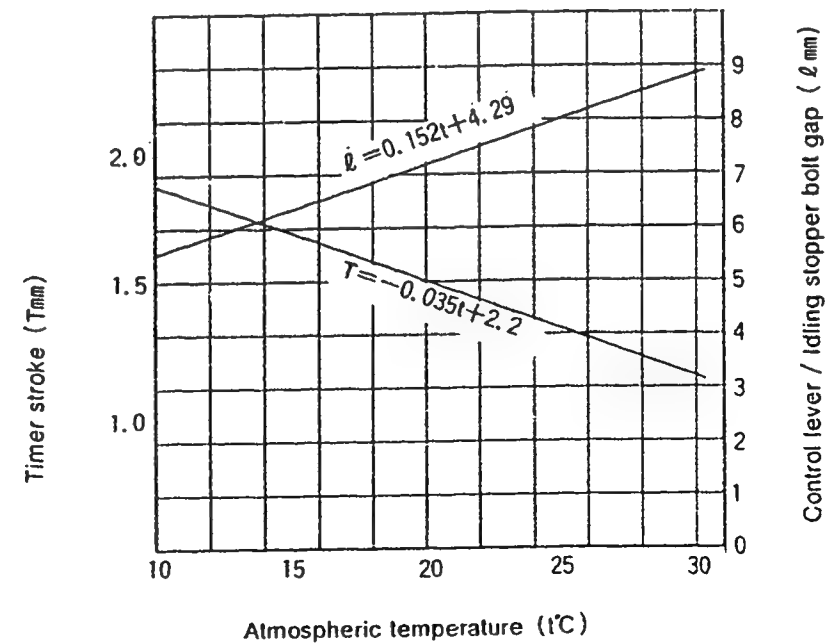

Fig. 2

INJ. PUMP CALIBRATION DATA

TEST OIL:
I S O 4113 or
S A E J967d

Distributor-type

ENGINE MODEL : 4D65-T

BOSCH No.9 460 610 197
DKKC No. 104749-3031
Date : 20.Nov.1986 0
Company : MITSUBISHI
No. MD110299

104749-3031 2/5

Injection pump No: 104649-3021 (NP-VE4/9F2250RNP280)

Pump rotation : clockwise-viewed from drive side

For Test Condition see
Microfiche No.WP-210(N16)

Pre-stroke : - mm

1. Setting	Pump speed (rpm)	Settings	Charge air press(mmHg)	Difference in delivery(cc)
1-1 Timing device travel	1,250	T=3.9~ 4.3 (mm)	580~600	
1-2 Supply pump pressure	1,250	4.5~ 5.1 (kg/cm ²)	580~600	
1-3 Full load delivery without charge air pressure	1,250	46.3~47.3 (cc/1,000st)	580~600	3.0
Full load delivery with charge air pressure	750	40.2~41.2 (cc/1,000st)	240~260	3.5
1-4 Idle speed regulation	400	5.0~ 8.0 (cc/1,000st)	0	2.0
1-5 Start	100	43.0~63.0 (cc/1,000st)	0	
1-6 Full-load speed regulation	2,750	3.5~ 9.5 (cc/1,000st)	0	
1-7 Load-timer adjustment	1,250	T-0.6±0.2 (mm)		
1-8				

2. Test Specifications

2-1 Timing device	N = rpm	600	1,250	2,250	
	mm	0.7~ 1.9	3.7~ 4.5	7.8~ 8.6	
2-2 Supply pump	N = rpm	600	1,250	2,250	
	kg/cm ²	2.9~ 3.5	4.5~ 5.1	6.8~ 7.4	
2-3 Overflow delivery	N = rpm	1,250			
	cc/10s	48.0~92.0			
2-4 Fuel deliveries					
Speed control lever	Pump speed (rpm)	Fuel delivery (cc/1,000st)	Charge air press(mmHg)	Difference in delivery	
End stop	1,250	45.8~47.8	580~600		
	750	39.7~41.7	240~260		
	600	32.7~37.7	0		
	2,250	38.2~43.2	580~600		
	2,750	1.5~11.5	0		
	3,000	Below 3.0	0		
Switch OFF	400	0			
Idle stop	600	Below 2.0	0		
	400	4.5~ 8.5	0		
2-5 Solenoid		Max.cut-in voltage : 8 V			
		Test voltage : 12~14 V			

3. Dimensions

K	3.2~3.4	mm
KF	5.7~5.9	mm
MS	0.9~1.1	mm
BCS	3.5~3.7	mm

Control lever angle

α	55.0~63.0	deg
A	10.5~16.0	mm
β	38.0~44.0	deg
B	11.5~14.1	mm
γ	—	deg
C	—	mm

LOAD TIMER ADJUSTMENT

1) Adjustment

① Fix the control lever in the position satisfying the following conditions.

Boost Pressure : — mmHg
Pump Speed : 1250 rpm
Fuel Injection : 33.2±1 cc/1000st
Quantity

② With the control lever positioned as described in ① above, adjust the governor sleeve so that the Timer Stroke conforms to the specified values (page 1/5)

2) Confirmation of Timer Characteristics

Fix the control lever in the position satisfying the following conditions, and confirm the Timer Stroke.

Control lever position			Specified Values	
Pump speed (rpm)	Fuel Injection Quantity(cc/1000st)	Boost pressure (mmHg)	Timer stroke (mm)	Timer stroke reduction value (mm)
1250	32.2~34.2	—	(3.5)	0.2~1.0
1250	24.2~26.2	—	(2.3~3.5)	(1.2)

■ DASH POT ADJUSTMENT

- ① Insert a block gauge (thickness gauge) of thickness 5.2 ± 1 in the gap between the control lever and the idling stopper bolt. (control lever angle : $6^\circ \sim 10^\circ$)
- ② With the control lever positioned as described in ① above, adjust the plate position so that the control lever plate and the dash pot push rod are in contact.

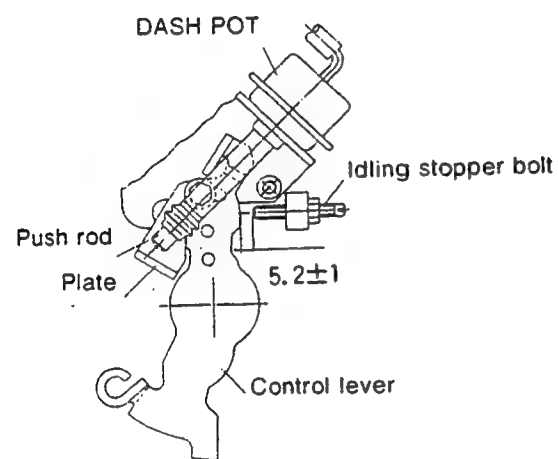

■ W-CSD ADJUSTMENT

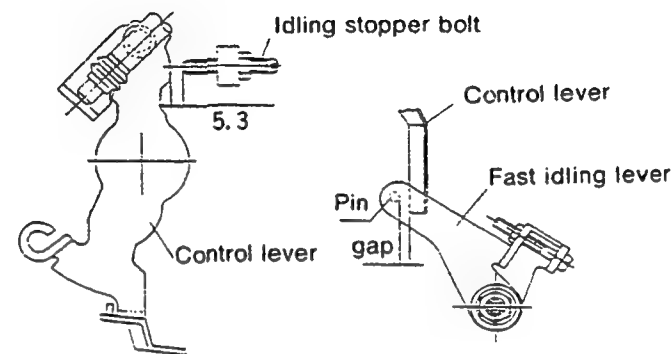

Fig. 1

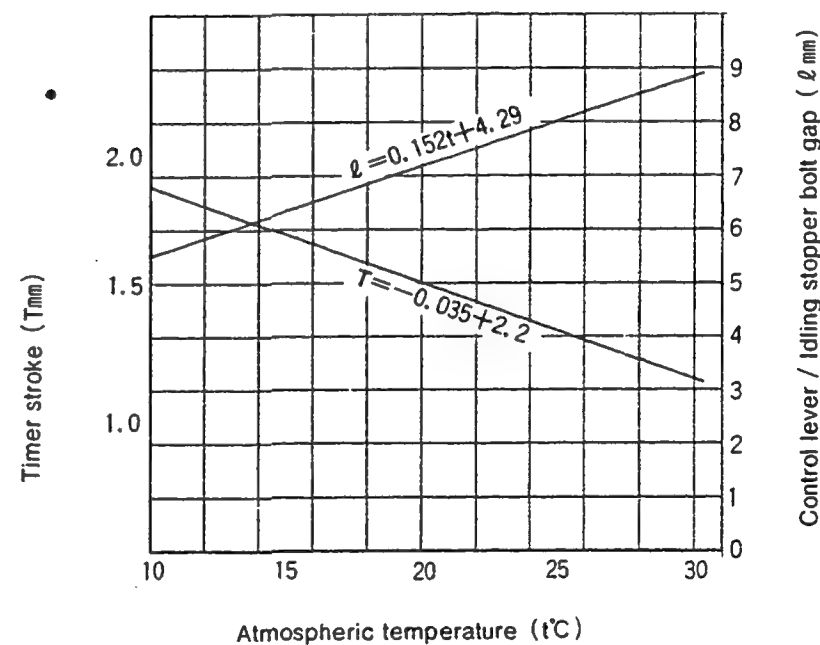

Fig. 2

○ Note

- ① At a pump speed of 1250 rpm and boost pressure of 590 mmHg, adjust the Full Load injection quantity after confirming the boost compensator stoppre's full stroke.
- ② At a pump speed of 750 rpm and boost pressure of 250 mmHg, adjust the full load fuel injection quantity (40.2~41.2 cc/1000st) using the BCS spring set screw.

1) Timer Stroke Adjustment (Refer to Fig 1.2)

- ① Using the graph (Fig 2) , determine the Timer Stroke according to the atmospheric temperature at the time of adjustment.
- ② Adjust using the Timer Stroke adjusting bolt so that the Timer Stroke corresponds to the value determined in note ① above.

2) Fast Idle Adjustment (Refer to Fig 1.2)

- ① Insert a block gauge of 5.3 ± 0.05 mm thickness in the gap between the control lever and the idling stopper bolt.

- ② From Fig 2 determine the dimension of the gap between the idling lever pin and the control lever according to the atmospheric temperature at the time of adjustment.
- ③ Adjust using the fast idle adjusting screw so that the gap corresponds to the value determined in note 2) ② above.

■ **POTENTIOMETER ADJUSTMENT**

Under the following conditions, after potentiometer installation position so that the out-put voltage equale the specified value.

Adjustment Conditions			Specified Value	Remarks
Control lever position	Pump speed (rpm)	Fuel Injection Quantity(cc/1000st)	Adjustment Value Out-put voltage (V)	
(Approx 19°)	1000	22.9	4±0.03	Adjusting point
Idel	—	—	0.8±0.7	Check point
Full speed	—	—	7.7±1.2	Check point

[In-put Voltage: V]

※ A control lever position of approximately 19 °, means that a block gauge of 12.1 mm thickness is inserted between the control lever and the idling stopper bolt.

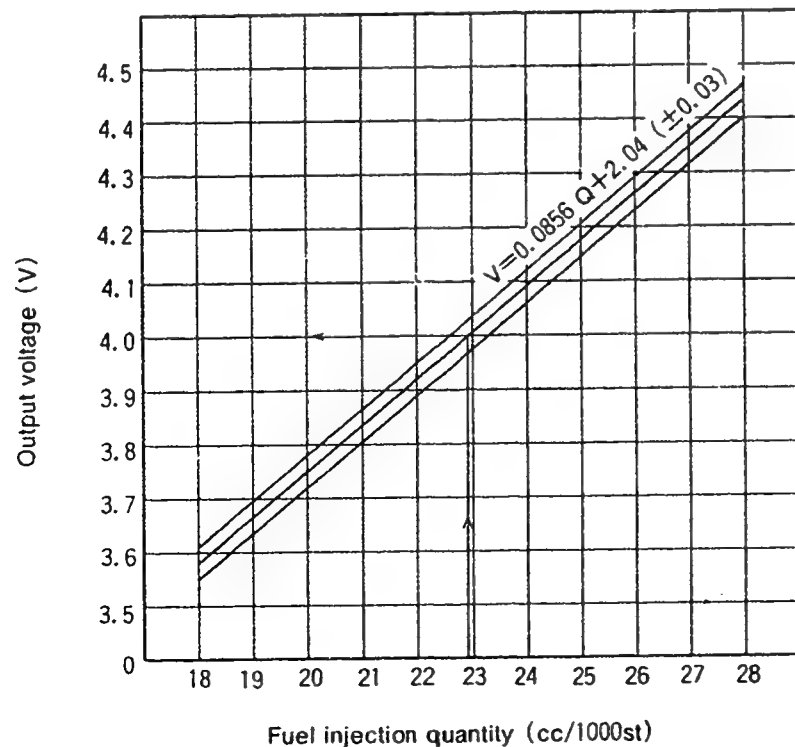

INJ. PUMP CALIBRATION DATA Distributor-type

TEST OIL:
I S O 4113 or
S A E J967d

ENGINE MODEL : SD22

Injection pump No: 104649-4110 [NP-VE4/9F2000RNP68]

Pump rotation : clockwise-viewed from drive side

Pre-stroke : 0.08~0.12 mm

BOSCH No.9 460 610 170

DKKC No. 104749-4110

Date : 20.Nov.1986 0

Company : NISSAN DIESEL

No. 16700 R8114

For Test Condition see
Microfiche No.WP-210(N16)

1. Setting	Pump speed (rpm)	Settings	Charge air press(mmHg)	Difference in delivery(cc)
1-1 Timing device travel	1,000	2.1~ 2.5 (mm)		2.5
1-2 Supply pump pressure	1,000	3.7~ 4.3 (kg/cm ²)		
1-3 Full load delivery without charge air pressure	1,000	33.0~34.0 (cc/1,000st)		
		Full load delivery with charge air pressure		
1-4 Idle speed regulation	300	5.0~ 9.0 (cc/1,000st)		2.0
1-5 Start	100	Above 49 (cc/1,000st)		
1-6 Full-load speed regulation	2,100	18.0~24.0 (cc/1,000st)		
1-7				
1-8				

2. Test Specifications

2-1 Timing device	N = rpm	1,000	1,400	1,900
	mm	2.0~ 2.6	3.6~ 4.8	6.2~ 7.1
2-2 Supply pump	N = rpm	500	1,000	1,900
	kg/cm ²	2.0~ 2.6	3.7~ 4.3	6.6~ 7.2
2-3 Overflow delivery	N = rpm	1,000		
	cc/10s	42~85		

2-4 Fuel injection quantities

Speed control lever position	Pump speed (rpm)	Fuel delivery (cc/1,000st)	Charge air press(mmHg)	Difference in delivery(cc)
Full speed position	1,000	32.5~34.5		
	600	28.4~32.4		
	1,400	35.1~39.1		
	2,000	31.5~35.5		
	2,100	18.0~24.0		
	2,300	Below 5		
Switch OFF	300	0		
Idling position	300	5.0~9.0		
	400	Below 3		

2-5 Solenoid Max.cut-in voltage : 8 V
Test voltage : 12~14 V

3. Dimensions

K	3.2~3.4	mm
KF	5.7~5.9	mm
MS	1.4~1.6	mm
BCS	—	mm

Control lever angle

α	21.0~29.0	deg
A	—	mm
β	37.0~47.0	deg
B	—	mm
γ	—	deg
C	—	mm

INJ. PUMP CALIBRATION DATA Distributor-type

TEST OIL:
I S O 4113 or
S A E J967d

ENGINE MODEL : SD22

Injection pump No: 104649-4111 [NP-VE4/9F2000RNP68]

Pump rotation : clockwise-viewed from drive side

Pre-stroke : 0.08~0.12 mm

BOSCH No.9 460 610 020

DKKC No. 104749-4111

Date : 20.Nov.1986 0

Company : NISSAN DIESEL

No. 16700 R8114

For Test Condition see
Microfiche No.WP-210(N16)

1. Setting	Pump speed (rpm)	Settings	Charge air press(mmHg)	Difference in delivery(cc)
1-1 Timing device travel	1,000	2.1~ 2.5 (mm)		2.5
1-2 Supply pump pressure	1,000	3.7~ 4.3 (kg/cm ²)		
1-3 Full load delivery without charge air pressure	1,000	33.0~34.0 (cc/1,000st)		
		Full load delivery with charge air pressure		
1-4 Idle speed regulation	300	5.0~ 9.0 (cc/1,000st)		2.0
1-5 Start	100	Above 49 (cc/1,000st)		
1-6 Full-load speed regulation	2,100	18.0~24.0 (cc/1,000st)		
1-7				
1-8				

2. Test Specifications

2-1 Timing device	N = rpm	1,000	1,400	1,900
	mm	2.0~ 2.6	3.6~ 4.8	6.2~ 7.1
2-2 Supply pump	N = rpm	500	1,000	1,900
	kg/cm ²	2.0~ 2.6	3.7~ 4.3	6.6~ 7.2
2-3 Overflow delivery	N = rpm	1,000		
	cc/10s	42~85		

2-4 Fuel injection quantities

Speed control lever position	Pump speed (rpm)	Fuel delivery (cc/1,000st)	Charge air press(mmHg)	Difference in delivery(cc)
Full speed position	1,000	32.5~34.5		
	600	28.4~32.4		
	1,400	35.1~39.1		
	2,000	31.5~35.5		
	2,100	18.0~24.0		
	2,300	Below 5		
Switch OFF	300	0		
Idling position	300	5.0~9.0		
	400	Below 3		

2-5 Solenoid Max.cut-in voltage : 8 V
Test voltage : 12~14 V

3. Dimensions

K	3.2~3.4	mm
KF	5.7~5.9	mm
MS	1.4~1.6	mm
BCS	—	mm

Control lever angle

α	21.0~29.0	deg
A	—	mm
β	37.0~47.0	deg
B	—	mm
γ	—	deg
C	—	mm

INJ. PUMP CALIBRATION DATA

TEST OIL:
I S O 4113 or
S A E J967d

Distributor-type

ENGINE MODEL : 4FC1-D

Injection pump No: 104649-1531 [NP-VE4/9F2250RNP222]

Pump rotation : clockwise-viewed from drive side

Pre-stroke : 0.23~0.27 mm

BOSCH No.9 460 610 181

DKKC No. 104749-6021

Date : 20.Nov.1986

Company : ISUZU

No. 894410 2520

For Test Condition see
Microfiche No.WP-210(N16)

1. Setting	Pump speed (rpm)	Settings	Difference in delivery(cc)
1-1 Timing device travel	1,250	3.7~ 4.1 (mm)	
1-2 Supply pump pressure	1,250	4.6~ 5.0 (kg/cm ²)	
1-3 Full load delivery	1,250	32.0~33.0 (cc/1,000st)	2.5
1-4 Idle speed regulation	330	5.6~ 9.6 (cc/1,000st)	2.0
1-5 Start	100	52.0~72.0 (cc/1,000st)	
1-6 Full-load speed regulation	2,600	14.5~16.5 (cc/1,000st)	
1-7			
1-8			

2. Test Specifications

2-1 Timing device	N = rpm mm	1,250 3.6~ 4.2	1,800 6.1~ 7.3	2,250 8.6~ 9.4
2-2 Supply pump	N = rpm kg/cm ²	1,250 4.6~ 5.0	2,000 6.2~ 6.8	
2-3 Overflow delivery	N = rpm cc/10s	1,250 58.0~102.0		

2-4 Fuel deliveries

Speed control lever	Pump speed (rpm)	Fuel delivery (cc/1,000st)	Difference in delivery
End stop	1,250	31.5~33.5	
	600	24.5~28.5	
	2,250	29.4~33.6	
	2,600	13.2~17.2	
	2,900	Below 5.0	
Switch OFF	330	0	
Idle stop	330	5.6~9.6	
	450	0	

3. Dimensions

K	3.2~3.4	mm
KF	5.7~5.9	mm
MS	1.5~1.7	mm
BCS	—	mm

Control lever angle

α	-7.0~1.0	deg
A	8.8~11.4	mm
β	32.0~42.0	deg
B	10.2~13.5	mm
γ	—	deg
C	—	mm

2-5 Solenoid Voltage : 12 V

INJ. PUMP CALIBRATION DATA

TEST OIL:
I S O 4113 or
S A E J967d

Distributor-type

ENGINE MODEL : 4FD1

Injection pump No: 104649-1910 [NP-VE4/9F2250RNP220]

Pump rotation : clockwise-viewed from drive side

Pre-stroke : 0.25 mm

BOSCH No.9 460 610 198

DKKC No. 104749-6500

Date : 20.Nov.1986

Company : ISUZU

No. 894433 1810

For Test Condition see
Microfiche No.WP-210(N16)

1. Setting	Pump speed (rpm)	Settings	Charge air press(mmHg)	Difference in delivery(cc)
1-1 Timing device travel	1,250	3.4~ 3.8 (mm)		
1-2 Supply pump pressure	1,250	4.6~ 5.0 (kg/cm ²)		
1-3 Full load delivery without charge air pressure	1,250	37.2~38.2 (cc/1,000st)		3.0
Full load delivery with charge air pressure		(cc/1,000st)		
1-4 Idle speed regulation	340	5.5~ 9.5 (cc/1,000st)		2.0
1-5 Start	100	50.0~70.0 (cc/1,000st)		4.5
1-6 Full-load speed regulation	2,600	13.1~19.1 (cc/1,000st)		
1-7				
1-8				

2. Test Specifications

2-1 Timing device	N = rpm mm	1,250 3.3~ 3.9	2,000 6.3~ 7.5	2,500 8.6~ 9.4
2-2 Supply pump	N = rpm kg/cm ²	1,250 4.6~ 5.0	2,000 6.2~ 6.8	2,500 7.6~ 8.2
2-3 Overflow delivery	N = rpm cc/10s	1,250 55.0~98.0		

2-4 Fuel deliveries

Speed control lever	Pump speed (rpm)	Fuel delivery (cc/1,000st)	Charge air press(mmHg)	Difference in delivery
End stop	1,250	36.7~38.7		
	600	30.7~34.7		
	2,250	33.1~37.3		
	2,600	12.6~19.6		
	2,900	Below 4.5		
Switch OFF	340	0		
Idle stop	340	5.5~ 9.5		
	500	0		

3. Dimensions

K	3.2~3.4	mm
KF	5.7~5.9	mm
MS	1.5~1.7	mm
BCS	—	mm

Control lever angle

α	-7.0~+1.0	deg
A	8.8~11.4	mm
β	32.0~42.0	deg
B	10.2~13.5	mm
γ	—	deg
C	—	mm

2-5 Solenoid Max.cut-in voltage : 8 V
Test voltage : 12~14 V

H - 6**INJ. PUMP CALIBRATION DATA**TEST OIL:
ISO 4113 or
SAE J967d

Distributor-type

ENGINE MODEL : 4FD1

Injection pump No: 104649-1910 [NP-VE4/9F2250RNP220]

BOSCH No.9 460 610 199

DKKC No. 104749-6510

Date : 20.Nov.1986 [0]

Company : ISUZU

No. 894433 1820

Pump rotation : clockwise-viewed from drive side

Pre-stroke : 0.25 mm

For Test Condition see
Microfiche No.WP-210(N16)

1. Setting	Pump speed (rpm)	Settings	Charge air press(mmHg)	Difference in delivery(cc)
1-1 Timing device travel	1,250	3.4~ 3.8 (mm)		
1-2 Supply pump pressure	1,250	4.6~ 5.0 (kg/cm ²)		
1-3 Full load delivery without charge air pressure	1,250	37.2~38.2 (cc/1,000st)		3.0
Full load delivery with charge air pressure		(cc/1,000st)		
1-4 Idle speed regulation	340	5.5~ 9.5 (cc/1,000st)		2.0
1-5 Start	100	50.0~70.0 (cc/1,000st)		4.5
1-6 Full-load speed regulation	2,600	13.1~19.1 (cc/1,000st)		
1-7				
1-8				

2. Test Specifications

2-1 Timing device	N = rpm	1,250	2,000	2,500
	mm	3.3~ 3.9	6.3~ 7.5	8.6~ 9.4
2-2 Supply pump	N = rpm	1,250	2,000	2,500
	kg/cm ²	4.6~ 5.0	6.2~ 6.8	7.6~ 8.2
2-3 Overflow delivery	N = rpm	1,250		
	cc/10s	55.0~98.0		
2-4 Fuel deliveries				
Speed control lever	Pump speed (rpm)	Fuel delivery (cc/1,000st)	Charge air press(mmHg)	Difference in delivery
End stop	1,250	36.7~38.7		
	600	30.7~34.7		
	2,250	33.1~37.3		
	2,600	12.6~19.6		
	2,900	Below 4.5		
Switch OFF	340	0		
Idle stop	340	5.5~ 9.5		
	500	0		
2-5 Solenoid	Max.cut-in voltage : 8 V Test voltage : 12~14 V			

3. Dimensions

K	3.2~3.4	mm
KF	5.7~5.9	mm
MS	1.5~1.7	mm
BCS	—	mm

Control lever angle

α	-7.0~+1.0	deg
A	8.8~11.4	mm
β	32.0~42.0	deg
B	10.2~13.5	mm
Y	—	deg
C	—	mm

**DIESEL KIKI**DIESEL KIKI CO., LTD. 3-8-7 SHIBUYA, SHIBUYA-KU, TOKYO 150, JAPAN
Service Department Tel. (03) 400-1551 Fax (03) 499-4115

INJ. PUMP CALIBRATION DATA Distributor-type

ENGINE MODEL : LD28

TEST OIL:
ISO 4113 or
SAE J967d

Injection pump No: 104660-2001 [NP-VE6/10F2500RNP1]

Pump rotation : clockwise-viewed from drive side

Pre-stroke : - mm

BOSCH No.9 460 610 081

DKKC No. 104760-2001

Date : 20.Nov.1986 [2]

Company : NISSAN

No. 16700 V0700

For Test Condition see
Microfiche No.WP-210(N16)

1. Setting	Pump speed (rpm)	Settings	Charge air press(mmHg)	Difference in delivery(cc)
1-1 Timing device travel	1,200	2.4~ 3.0 (mm)		
1-2 Supply pump pressure	1,800	5.7~ 6.3 (kg/cm ²)		
1-3 Full load delivery without charge air pressure	1,200	33.8~34.8 (cc/1,000st)		2.5
Full load delivery with charge air pressure		(cc/1,000st)		
1-4 Idle speed regulation	350	6.7~ 9.7 (cc/1,000st)		3.0
1-5 Start	100	Above 47 (cc/1,000st)		
1-6 Full-load speed regulation	2,700	7.0~13.0 (cc/1,000st)		
1-7				
1-8				

2. Test Specifications

2-1 Timing device	N = rpm mm	1,200 2.3~ 3.1	1,800 4.8~ 6.0	2,300 7.7~ 8.6
2-2 Supply pump	N = rpm kg/cm ²	800 3.3~ 4.1	1,800 5.6~ 6.4	2,500 7.1~ 7.9
2-3 Overflow delivery	N = rpm cc/10s	1,000 53.0~97.0		

2-4 Fuel injection quantities

Speed control lever position	Pump speed (rpm)	Fuel delivery (cc/1,000st)	Charge air press(mmHg)	Difference in delivery(cc)
Full speed position	1,200	33.3~35.3		
	600	27.0~31.0		
	2,300	28.4~32.4		
	2,700	6.5~13.5		
	2,800	Below 5		
Switch OFF	350	0		
Idling position	350	6.2~10.2		
	500	Below 4		
Partial load	900	12.0~22.0		
2-5 Solenoid	Max.cut-in voltage : 8 V Test voltage : 12~14 V			

3. Dimensions

K	3.2~3.4 mm
KF	6.54~6.74 mm
MS	1.7~1.9 mm
BCS	- mm
Control lever angle	
α	21.0~29.0 deg
A	2.5~ 8.0 mm
β	39.0~49.0 deg
B	11.0~16.0 mm
γ	10.5~11.5 deg
C	6.7~ 7.3 mm

INJ. PUMP CALIBRATION DATA Distributor-type

ENGINE MODEL : LD28

TEST OIL:
ISO 4113 or
SAE J967d

Injection pump No: 104660-2002 [NP-VE6/10F2500RNP1]

Pump rotation : clockwise-viewed from drive side

Pre-stroke : - mm

BOSCH No.9 460 612 021

DKKC No. 104760-2002

Date : 20.Nov.1986 [2]

Company : NISSAN

No. 16700 V0701

For Test Condition see
Microfiche No.WP-210(N16)

1. Setting	Pump speed (rpm)	Settings	Charge air press(mmHg)	Difference in delivery(cc)
1-1 Timing device travel	1,200	2.4~ 3.0 (mm)		
1-2 Supply pump pressure	1,800	5.7~ 6.3 (kg/cm ²)		
1-3 Full load delivery without charge air pressure	1,200	33.8~34.8 (cc/1,000st)		2.5
Full load delivery with charge air pressure		(cc/1,000st)		
1-4 Idle speed regulation	350	6.7~ 9.7 (cc/1,000st)		3.0
1-5 Start	100	Above 47 (cc/1,000st)		
1-6 Full-load speed regulation	2,700	7.0~13.0 (cc/1,000st)		
1-7				
1-8				

2. Test Specifications

2-1 Timing device	N = rpm mm	1,200 2.3~ 3.1	1,800 4.8~ 6.0	2,300 7.7~ 8.6
2-2 Supply pump	N = rpm kg/cm ²	800 3.3~ 4.1	1,800 5.6~ 6.4	2,500 7.1~ 7.9
2-3 Overflow delivery	N = rpm cc/10s	1,000 53.0~97.0		

2-4 Fuel injection quantities

Speed control lever position	Pump speed (rpm)	Fuel delivery (cc/1,000st)	Charge air press(mmHg)	Difference in delivery(cc)
Full speed position	1,200	33.3~35.3		
	600	27.0~31.0		
	2,300	28.4~32.4		
	2,700	6.5~13.5		
	2,800	Below 5		
Switch OFF	350	0		
Idling position	350	6.2~10.2		
	500	Below 4		
Partial load	900	12.0~22.0		
2-5 Solenoid	Max.cut-in voltage : 8 V Test voltage : 12~14 V			

3. Dimensions

K	3.2~3.4 mm
KF	6.54~6.74 mm
MS	1.7~1.9 mm
BCS	- mm
Control lever angle	
α	21.0~29.0 deg
A	2.5~ 8.0 mm
β	39.0~49.0 deg
B	11.0~16.0 mm
γ	10.5~11.5 deg
C	6.7~ 7.3 mm

INJ. PUMP CALIBRATION DATA Distributor-type

TEST OIL:
I S O 4113 or
S A E J967d

ENGINE MODEL : LD28

Injection pump No: 104660-2010 [NF-VE6/10F2500RNP2]

Pump rotation : clockwise-viewed from drive side

Pre-stroke : - mm

BOSCH No.9 460 610 082

DKKC No. 104760-2020

Date : 20.Nov.1986 [2]

Company : NISSAN

No. 16700 S8201

For Test Condition see
Microfiche No.WP-210(N16)

1. Setting	Pump speed (rpm)	Settings	Charge air press(mmHg)	Difference in delivery(cc)
1-1 Timing device travel	1,200	2.4~3.0 (mm)		
1-2 Supply pump pressure	1,800	5.7~6.3 (kg/cm ²)		
1-3 Full load delivery without charge air pressure	1,200	33.8~34.8 (cc/1,000st)		2.5
Full load delivery with charge air pressure		(cc/1,000st)		
1-4 Idle speed regulation	350	6.7~9.7 (cc/1,000st)		3.0
1-5 Start	100	Above 47 (cc/1,000st)		
1-6 Full-load speed regulation	2,700	7.0~13.0 (cc/1,000st)		
1-7				
1-8				

2. Test Specifications

2-1 Timing device	N = rpm mm	1,200 2.3~3.1	1,800 4.8~6.0	2,300 7.7~8.6
2-2 Supply pump	N = rpm kg/cm ²	800 3.3~4.1	1,800 5.6~6.4	2,500 7.1~7.9
2-3 Overflow delivery	N = rpm cc/10s	1,000 53.0~97.0		

2-4 Fuel injection quantities

Speed control lever position	Pump speed (rpm)	Fuel delivery (cc/1,000st)	Charge air press(mmHg)	Difference in delivery(cc)
Full speed position	1,200	33.3~35.3		
	600	27.0~31.0		
	2,300	28.4~32.4		
	2,700	6.5~13.5		
	2,800	Below 5		
Switch OFF	350	0		
Idling position	350	6.2~10.2		
	500	Below 4		
Partial load	900	12.0~22.0		

2-5 Solenoid Max.cut-in voltage : 8 V
Test voltage : 12~14 V

3. Dimensions

K	3.2~3.4 mm
KF	6.54~6.74 mm
MS	1.7~1.9 mm
BCS	- mm

Control lever angle

α	21.0~29.0 deg
A	2.5~8.0 mm
β	39.0~49.0 deg
B	11.0~16.0 mm
Y	10.5~11.5 deg
C	6.7~7.3 mm

INJ. PUMP CALIBRATION DATA Distributor-type

TEST OIL:
I S O 4113 or
S A E J967d

ENGINE MODEL : LD28

Injection pump No: 104660-2011 [NP-VE6/10F2500RNP2]

Pump rotation : clockwise-viewed from drive side

Pre-stroke : - mm

BOSCH No.9 460 610 083

DKKC No. 104760-2021

Date : 20.Nov.1986 [2]

Company : NISSAN

No. 16700 S8201

For Test Condition see
Microfiche No.WP-210(N16)

1. Setting	Pump speed (rpm)	Settings	Charge air press(mmHg)	Difference in delivery(cc)
1-1 Timing device travel	1,200	2.4~3.0 (mm)		
1-2 Supply pump pressure	1,800	5.7~6.3 (kg/cm ²)		
1-3 Full load delivery without charge air pressure	1,200	33.8~34.8 (cc/1,000st)		2.5
Full load delivery with charge air pressure		(cc/1,000st)		
1-4 Idle speed regulation	350	6.7~9.7 (cc/1,000st)		3.0
1-5 Start	100	Above 47 (cc/1,000st)		
1-6 Full-load speed regulation	2,700	7.0~13.0 (cc/1,000st)		
1-7				
1-8				

2. Test Specifications

2-1 Timing device	N = rpm mm	1,200 2.3~3.1	1,800 4.8~6.0	2,300 7.7~8.6
2-2 Supply pump	N = rpm kg/cm ²	800 3.3~4.1	1,800 5.6~6.4	2,500 7.1~7.9
2-3 Overflow delivery	N = rpm cc/10s	1,000 53.0~97.0		

2-4 Fuel injection quantities

Speed control lever position	Pump speed (rpm)	Fuel delivery (cc/1,000st)	Charge air press(mmHg)	Difference in delivery(cc)
Full speed position	1,200	33.3~35.3		
	600	27.0~31.0		
	2,300	28.4~32.4		
	2,700	6.5~13.5		
	2,800	Below 5		
Switch OFF	350	0		
Idling position	350	6.2~10.2		
	500	Below 4		
Partial load	900	12.0~22.0		

2-5 Solenoid Max.cut-in voltage : 8 V
Test voltage : 12~14 V

3. Dimensions

K	3.2~3.4 mm
KF	6.54~6.74 mm
MS	1.7~1.9 mm
BCS	- mm

Control lever angle

α	21.0~29.0 deg
A	2.5~8.0 mm
β	39.0~49.0 deg
B	11.0~16.0 mm
Y	10.5~11.5 deg
C	6.7~7.3 mm

INJ. PUMP CALIBRATION DATA Distributor-type

ENGINE MODEL : LD28

TEST OIL:
I S O 4113 or
S A E J967d

Injection pump No: 104660-2050 [NP-VE6/10F2500RNP1]

Pump rotation : clockwise-viewed from drive side

Pre-stroke : - mm

BOSCH No.9 460 610 084

DKKC No. 104760-2070

Date : 20.Nov.1986 [2]

Company : NISSAN

No. 16700 28L00

For Test Condition see
Microfiche No.WP-210(N16)

1. Setting	Pump speed (rpm)	Settings	Charge air press(mmHg)	Difference in delivery(cc)
1-1 Timing device travel	1,200	2.4~3.0 (mm)		
1-2 Supply pump pressure	1,800	5.7~6.3 (kg/cm ²)		
1-3 Full load delivery without charge air pressure	1,200	33.8~34.8 (cc/1,000st)		2.5
Full load delivery with charge air pressure		(cc/1,000st)		
1-4 Idle speed regulation	350	6.7~9.7 (cc/1,000st)		3.0
1-5 Start	100	Above 47 (cc/1,000st)		
1-6 Full-load speed regulation	2,700	7.0~13.0 (cc/1,000st)		
1-7				
1-8				

2. Test Specifications

2-1 Timing device	N = rpm mm	1,200 2.3~3.1	1,800 4.8~6.0	2,300 7.7~8.6
2-2 Supply pump	N = rpm kg/cm ²	800 3.3~4.1	1,800 5.6~6.4	2,500 7.1~7.9
2-3 Overflow delivery	N = rpm cc/10s	1,000 53.0~97.0		

2-4 Fuel injection quantities

Speed control lever position	Pump speed (rpm)	Fuel delivery (cc/1,000st)	Charge air press(mmHg)	Difference in delivery(cc)
Full speed position	1,200	33.3~35.3		
	600	27.0~31.0		
	2,300	28.4~32.4		
	2,700	6.5~13.5		
	2,800	Below 5		
Switch OFF	350	0		
Idling position	350	6.2~10.2		
	500	Below 4		
Partial load	900	12.0~22.0		
2-5 Solenoid	Max.cut-in voltage : 8 V Test voltage : 12~14 V			

3. Dimensions

K	3.2~3.4 mm
KF	6.54~6.74 mm
MS	1.7~1.9 mm
BCS	- mm
Control lever angle	
α	21.0~29.0 deg
A	2.5~8.0 mm
β	39.0~49.0 deg
B	11.0~16.0 mm
γ	10.5~11.5 deg
C	6.7~7.3 mm

INJ. PUMP CALIBRATION DATA Distributor-type

ENGINE MODEL : LD28

TEST OIL:
I S O 4113 or
S A E J967d

Injection pump No: 104660-2081 [NP-VE6/10F2500RNP1]

Pump rotation : clockwise-viewed from drive side

Pre-stroke : - mm

BOSCH No.9 460 610 085

DKKC No. 104760-2111

Date : 20.Nov.1986 [2]

Company : NISSAN

No. 16700 V2100

For Test Condition see
Microfiche No.WP-210(N16)

1. Setting	Pump speed (rpm)	Settings	Charge air press(mmHg)	Difference in delivery(cc)
1-1 Timing device travel	1,200	2.4~3.0 (mm)		
1-2 Supply pump pressure	1,800	5.7~6.3 (kg/cm ²)		
1-3 Full load delivery without charge air pressure	1,200	33.8~34.8 (cc/1,000st)		2.5
Full load delivery with charge air pressure		(cc/1,000st)		
1-4 Idle speed regulation	350	6.7~9.7 (cc/1,000st)		3.0
1-5 Start	100	Above 47 (cc/1,000st)		
1-6 Full-load speed regulation	2,700	7.0~13.0 (cc/1,000st)		
1-7				
1-8				

2. Test Specifications

2-1 Timing device	N = rpm mm	1,200 2.3~3.1	1,800 4.8~6.0	2,300 7.7~8.6
2-2 Supply pump	N = rpm kg/cm ²	800 3.3~4.1	1,800 5.6~6.4	2,500 7.1~7.9
2-3 Overflow delivery	N = rpm cc/10s	1,000 53.0~97.0		

2-4 Fuel injection quantities

Speed control lever position	Pump speed (rpm)	Fuel delivery (cc/1,000st)	Charge air press(mmHg)	Difference in delivery(cc)
Full speed position	1,200	33.3~35.3		
	600	27.0~31.0		
	2,300	28.4~32.4		
	2,700	6.5~13.5		
	2,800	Below 5		
Switch OFF	350	0		
Idling position	350	6.2~10.2		
	500	Below 4		
Partial load	900	12.0~22.0		
2-5 Solenoid	Max.cut-in voltage : 8 V Test voltage : 12~14 V			

3. Dimensions

K	3.2~3.4 mm
KF	6.54~6.74 mm
MS	1.7~1.9 mm
BCS	- mm
Control lever angle	
α	21.0~29.0 deg
A	2.5~8.0 mm
β	39.0~49.0 deg
B	11.0~16.0 mm
γ	10.5~11.5 deg
C	6.7~7.3 mm

INJ. PUMP CALIBRATION DATA Distributor-type

ENGINE MODEL : LD28

TEST OIL:
I S O 4113 or
S A E J967d

Injection pump No: 104660-2092 (NP-VE6/10F2500RNP1)

Pump rotation : clockwise-viewed from drive side

Pre-stroke : - mm

BOSCH No.9 460 610 086

DKKC No. 104760-2132

Date : 20.Nov.1986 2

Company : NISSAN

No. 16700 28L10

For Test Condition see
Microfiche No.WP-210(N16)

1. Setting	Pump speed (rpm)	Settings	Charge air press(mmHg)	Difference in delivery(cc)
1-1 Timing device travel	1,200	2.4~ 3.0 (mm)		
1-2 Supply pump pressure	1,800	5.7~ 6.3 (kg/cm ²)		
1-3 Full load delivery without charge air pressure	1,200	33.8~34.8 (cc/1,000st)		2.5
Full load delivery with charge air pressure		(cc/1,000st)		
1-4 Idle speed regulation	350	6.7~ 9.7 (cc/1,000st)		3.0
1-5 Start	100	Above 47 (cc/1,000st)		
1-6 Full-load speed regulation	2,700	7.0~13.0 (cc/1,000st)		
1-7				
1-8				

2. Test Specifications

2-1 Timing device	N = rpm	1,200	1,800	2,300
	mm	2.3~ 3.1	4.8~ 6.0	7.7~ 8.6
2-2 Supply pump	N = rpm	800	1,800	2,500
	kg/cm ²	3.3~ 4.1	5.6~ 6.4	7.1~ 7.9
2-3 Overflow delivery	N = rpm	1,000		
	cc/10s	53.0~97.0		

2-4 Fuel injection quantities				
Speed control lever position	Pump speed (rpm)	Fuel delivery (cc/1,000st)	Charge air press(mmHg)	Difference in delivery(cc)
Full speed position	1,200	33.3~35.3		
	600	27.0~31.0		
	2,300	28.4~32.4		
	2,700	6.5~13.5		
	2,800	Below 5		
Switch OFF	350	0		
Idling position	350	6.2~10.2		
	500	Below 4		
Partial load	900	12.0~22.0		
2-5 Solenoid	Max.cut-in voltage : 8 V Test voltage : 12~14 V			

3. Dimensions

K	3.2~3.4	mm
KF	6.54~6.74	mm
MS	1.7~1.9	mm
BCS	-	mm
Control lever angle		
α	21.0~29.0	deg
A	2.5~ 8.0	mm
β	39.0~49.0	deg
B	11.0~16.0	mm
γ	10.5~11.5	deg
C	6.7~ 7.3	mm

INJ. PUMP CALIBRATION DATA Distributor-type

ENGINE MODEL : LD28

TEST OIL:
I S O 4113 or
S A E J967d

Injection pump No: 104660-2093 (NP-VE6/10F2500RNP1)

Pump rotation : clockwise-viewed from drive side

Pre-stroke : - mm

BOSCH No.9 460 610 087

DKKC No. 104760-2133

Date : 20.Nov.1986 2

Company : NISSAN

No. 16700 28L10

For Test Condition see
Microfiche No.WP-210(N16)

1. Setting	Pump speed (rpm)	Settings	Charge air press(mmHg)	Difference in delivery(cc)
1-1 Timing device travel	1,200	2.4~ 3.0 (mm)		
1-2 Supply pump pressure	1,800	5.7~ 6.3 (kg/cm ²)		
1-3 Full load delivery without charge air pressure	1,200	33.8~34.8 (cc/1,000st)		2.5
Full load delivery with charge air pressure		(cc/1,000st)		
1-4 Idle speed regulation	350	6.7~ 9.7 (cc/1,000st)		3.0
1-5 Start	100	Above 47 (cc/1,000st)		
1-6 Full-load speed regulation	2,700	7.0~13.0 (cc/1,000st)		
1-7				
1-8				

2. Test Specifications

2-1 Timing device	N = rpm	1,200	1,800	2,300
	mm	2.3~ 3.1	4.8~ 6.0	7.7~ 8.6
2-2 Supply pump	N = rpm	800	1,800	2,500
	kg/cm ²	3.3~ 4.1	5.6~ 6.4	7.1~ 7.9
2-3 Overflow delivery	N = rpm	1,000		
	cc/10s	53.0~97.0		

2-4 Fuel injection quantities				
Speed control lever position	Pump speed (rpm)	Fuel delivery (cc/1,000st)	Charge air press(mmHg)	Difference in delivery(cc)
Full speed position	1,200	33.3~35.3		
	600	27.0~31.0		
	2,300	28.4~32.4		
	2,700	6.5~13.5		
	2,800	Below 5		
Switch OFF	350	0		
Idling position	350	6.2~10.2		
	500	Below 4		
Partial load	900	12.0~22.0		
2-5 Solenoid	Max.cut-in voltage : 8 V Test voltage : 12~14 V			

3. Dimensions

K	3.2~3.4	mm
KF	6.54~6.74	mm
MS	1.7~1.9	mm
BCS	-	mm
Control lever angle		
α	21.0~29.0	deg
A	2.5~ 8.0	mm
β	39.0~49.0	deg
B	11.0~16.0	mm
γ	10.5~11.5	deg
C	6.7~ 7.3	mm

H - 11**INJ. PUMP CALIBRATION DATA**
Distributor-typeTEST OIL:
I S O 4113 or
S A E J967d

ENGINE MODEL : LD28

Injection pump No: 104660-2050 (NP-VE6/10F2500RNP1)

BOSCH No.9 460 610 088

DKKC No. 104760-2160

Date : 20.Nov.1986 [2]

Company : NISSAN

No. 16700 28L90

Pump rotation : clockwise-viewed from drive side

For Test Condition see
Microfiche No.WP-210(N16)

Pre-stroke : - mm

1. Setting	Pump speed (rpm)	Settings	Charge air press(mmHg)	Difference in delivery(cc)
1-1 Timing device travel	1,200	2.4~ 3.0 (mm)		
1-2 Supply pump pressure	1,800	5.7~ 6.3 (kg/cm ²)		
1-3 Full load delivery without charge air pressure	1,200	33.8~34.8 (cc/1,000st)		2.5
Full load delivery with charge air pressure		(cc/1,000st)		
1-4 Idle speed regulation	350	6.7~ 9.7 (cc/1,000st)		3.0
1-5 Start	100	Above 47 (cc/1,000st)		
1-6 Full-load speed regulation	2,700	7.0~13.0 (cc/1,000st)		
1-7				
1-8				

2. Test Specifications

2-1 Timing device	N = rpm mm	1,200 2.3~ 3.1	1,800 4.8~ 6.0	2,300 7.7~ 8.6
2-2 Supply pump	N = rpm kg/cm ²	800 3.3~ 4.1	1,800 5.6~ 6.4	2,500 7.1~ 7.9
2-3 Overflow delivery	N = rpm cc/10s	1,000 53.0~97.0		
2-4 Fuel injection quantiles				
Speed control lever position	Pump speed (rpm)	Fuel delivery (cc/1,000st)	Charge air press(mmHg)	Difference in delivery(cc)
Full speed position	1,200	33.3~35.3		
	600	27.0~31.0		
	2,300	28.4~32.4		
	2,700	6.5~13.5		
	2,800	Below 5		
Switch OFF	350	0		
Idling position	350	6.2~10.2		
	500	Below 4		
Partial load	900	12.0~22.0		
2-5 Solenoid		Max.cut-in voltage : 8 V Test voltage : 12~14 V		

3. Dimensions

K	3.2~3.4 mm
KF	6.54~6.74 mm
MS	1.7~1.9 mm
BCS	- mm

Control lever angle

α	21.0~29.0 deg
A	2.5~ 8.0 mm
β	39.0~49.0 deg
B	11.0~16.0 mm
γ	10.5~11.5 deg
C	6.7~ 7.3 mm

**DIESEL KIKI CO., LTD.**
Service Department3-6-7 SHIBUYA, SHIBUYA-KU, TOKYO 150, JAPAN
Tel. (03) 400-1551 Fax: (03) 499-4115

INJ. PUMP CALIBRATION DATA Distributor-type

BOSCH No.9 460 610 089
DKKC No. 104760-2230
Date: 20.Nov.1986 2
Company: NISSAN
No. 16700 V3100

104760-2230

TEST OIL:
ISO 4113 or
SAE J967d

ENGINE MODEL : LD28

Injection pump No: 104660-2160 (NP-VE6/10F2500RNP1)

Pump rotation : clockwise-viewed from drive side

For Test Condition see
Microfiche No.WP-210(N16)

Pre-stroke : - mm

1. Setting	Pump speed (rpm)	Settings	Charge air press(mmHg)	Difference in delivery(cc)
1-1 Timing device travel	1,200	2.4~ 3.0 (mm)		
1-2 Supply pump pressure	1,800	5.7~ 6.3 (kg/cm ²)		
1-3 Full load delivery without charge air pressure	1,200	33.8~34.8 (cc/1,000st)		2.5
Full load delivery with charge air pressure		(cc/1,000st)		
1-4 Idle speed regulation	350	6.7~ 9.7 (cc/1,000st)		3.0
1-5 Start	100	48.0~58.0 (cc/1,000st)		
1-6 Full-load speed regulation	2,700	7.0~13.0 (cc/1,000st)		
1-7				
1-8				

2. Test Specifications

2-1 Timing device	N = rpm	1,200	1,800	2,300	
	mm	2.3~ 3.1	4.8~ 6.0	7.7~ 8.6	
2-2 Supply pump	N = rpm	800	1,800	2,500	
	kg/cm ²	3.3~ 4.1	5.6~ 6.4	7.1~ 7.9	
2-3 Overflow delivery	N = rpm	1,000			
	cc/10s	53.0~97.0			
2-4 Fuel injection quantities					
Speed control lever position	Pump speed (rpm)	Fuel delivery (cc/1,000st)	Charge air press(mmHg)	Difference in delivery(cc)	
Full speed position	1,200	33.3~35.3			
	600	27.0~31.0			
	2,300	28.4~32.4			
	2,700	6.5~13.5			
	2,800	Below 5			
Switch OFF	350	0			
Idling position	350	6.2~10.2			
	500	Below 4			
Partial load	900	12.0~22.0			
2-5 Solenoid	Max.cut-in voltage : 8 V Test voltage : 12~14 V				

3. Dimensions

K	3.2~3.4	mm
KF	6.54~6.74	mm
MS	1.7~1.9	mm
BCS	-	mm
Control lever angle		
α	21.0~29.0	deg
A	2.5~ 8.0	mm
β	39.0~49.0	deg
B	11.0~16.0	mm
γ	10.5~11.5	deg
C	6.7~ 7.3	mm

Starting Injection Quantity Adjustment

Adjust the starting injection quantity (item 1/5) using the adjusting bolt (as shown in the figure at right).

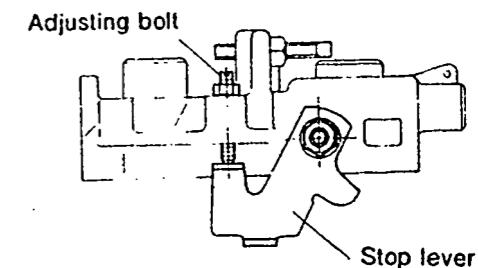

INJ. PUMP CALIBRATION DATA Distributor-type

TEST OIL:
I S O 4113 or
S A E J967d

ENGINE MODEL : LD28

BOSCH No. 9 460 610 166
DKKC No. 104760-2232
Date: 20 Nov. 1986 2
Company: NISSAN
No. 15700 V3100

104760-2232

Injection pump No: 104660-2162 (NP-VE6/10F2500RNP1)

Pump rotation : clockwise-viewed from drive side

For Test Condition see
Microfiche No.WP-210(N16)

Pre-stroke : — mm

1. Setting	Pump speed (rpm)	Settings	Charge air press(mmHg)	Difference in delivery(cc)
1-1 Timing device travel	1,200	2.4~ 3.0 (mm)		
1-2 Supply pump pressure	1,800	5.7~ 6.3 (kg/cm ²)		
1-3 Full load delivery without charge air pressure	1,200	33.8~34.8 (cc/1,000st)		2.5
Full load delivery with charge air pressure		(cc/1,000st)		
1-4 Idle speed regulation	350	6.7~ 9.7 (cc/1,000st)		3.0
1-5 Start	100	48.0~58.0 (cc/1,000st)		
1-6 Full-load speed regulation	2,700	7.0~13.0 (cc/1,000st)		
1-7				
1-8				

2. Test Specifications

2-1 Timing device	N = rpm mm	1,200 2.3~ 3.1	1,800 4.8~ 6.0	2,300 7.7~ 8.6
2-2 Supply pump	N = rpm kg/cm ²	800 3.3~ 4.1	1,800 5.6~ 6.4	2,500 7.1~ 7.9
2-3 Overflow delivery	N = rpm cc/10s	1,000 53.0~97.0		

2-4 Fuel injection quantities

Speed control lever position	Pump speed (rpm)	Fuel delivery (cc/1,000st)	Charge air press(mmHg)	Difference in delivery(cc)
Full speed position	1,200	33.3~35.3		
	600	27.0~31.0		
	2,300	28.4~32.4		
	2,700	6.5~13.5		
	2,800	Below 5		
Switch OFF	350	0		
Idling position	350	6.2~10.2		
	500	Below 4		
Partial load	900	12.0~22.0		

3. Dimensions

K	3.2~3.4	mm
KF	6.54~6.74	mm
MS	1.7~1.9	mm
BCS	—	mm

Control lever angle

α	21.0~29.0	deg
A	2.5~ 8.0	mm
β	39.0~49.0	deg
B	11.0~16.0	mm
γ	10.5~11.5	deg
C	6.7~ 7.3	mm

Starting Injection Quantity Adjustment

Adjust the starting injection quantity
(item 1/5) using the adjusting bolt
(as shown in the figure at right) .

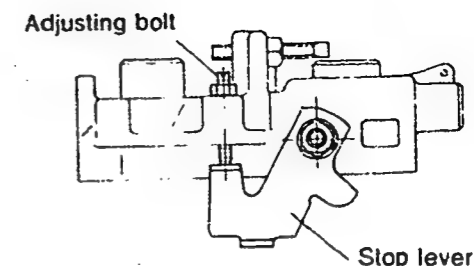

2-5 Solenoid Max.cut-in voltage : 8 V
Test voltage : 12~14 V

INJ. PUMP CALIBRATION DATA

Distributor-type

TEST OIL:
ISO 4113 or
SAE J967d

ENGINE MODEL : LD28

Injection pump No: 104660-2160 (NP-VE6/10F2500RNP1)

Pump rotation : clockwise-viewed from drive side

Pre-stroke : - mm

BOSCH No.9 460 610 090

DKKC No. 104760-2240

Date : 20.Nov.1986 2

Company : NISSAN

No. 16700 V3161

For Test Condition see
Microfiche No.WP-210(N16)

104760-2240

■ Starting Injection Quantity Adjustment

Adjust the starting injection quantity
(item 1/5) using the adjusting bolt
(as shown in the figure at right) .

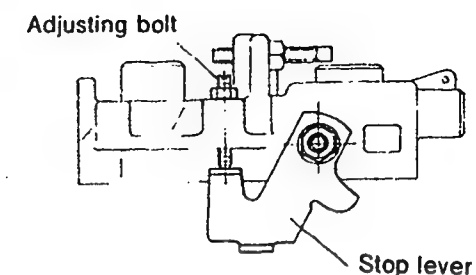

1. Setting	Pump speed (rpm)	Settings	Charge air press(mmHg)	Difference in delivery(cc)
1-1 Timing device travel	1,200	2.4~ 3.0 (mm)		
1-2 Supply pump pressure	1,800	5.7~ 6.3 (kg/cm ²)		
1-3 Full load delivery without charge air pressure	1,200	29.6~30.6 (cc/1,000st)		2.5
Full load delivery with charge air pressure		(cc/1,000st)		
1-4 Idle speed regulation	350	6.7~ 9.7 (cc/1,000st)		3.0
1-5 Start	100	48~58 (cc/1,000st)		
1-6 Full-load speed regulation	2,700	7.0~13.0 (cc/1,000st)		
1-7				
1-8				

2. Test Specifications

2-1 Timing device	N = rpm	1,200	1,800	2,300
	mm	2.3~ 3.1	4.8~ 6.0	7.7~ 8.6
2-2 Supply pump	N = rpm	800	1,800	2,500
	kg/cm ²	3.3~ 4.1	5.6~ 6.4	7.1~ 7.9
2-3 Overflow delivery	N = rpm	1,000		
	cc/10s	53.0~97.0		
2-4 Fuel injection quantities				
Speed control lever position	Pump speed (rpm)	Fuel delivery (cc/1,000st)	Charge air press(mmHg)	Difference in delivery(cc)
Full speed position	1,200	29.1~31.1		
	600	21.4~25.4		
	2,300	25.3~29.3		
	2,700	6.5~13.5		
	2,800	Below 5		
Switch OFF	350	0		
Idling position	350	6.2~10.2		
	500	Below 4		
Partial load	900	8.1~18.1		
2-5 Solenoid	Max.cut-in voltage : 8 V Test voltage : 12~14 V			

3. Dimensions

K	3.2~3.4	mm
KF	6.54~6.74	mm
MS	1.7~1.9	mm
BCS	-	mm
Control lever angle		
α	21.0~29.0	deg
A	2.5~ 8.0	mm
β	39.0~49.0	deg
B	11.0~16.0	mm
γ	10.5~11.5	deg
C	6.7~ 7.3	mm

INJ. PUMP CALIBRATION DATA

Distributor-type

BOSCH No.9 460 610 091
 DKKC No. 104760-2242
 Date : 20.Nov.1986 2
 Company : NISSAN
 No. 16700 V3161

104760-2242

TEST OIL:
 I S O 4113 or
 S A E J967d

ENGINE MODEL : LD28

Injection pump No: 104660-2162 [NP-VE6/10F2500RNP1]

Pump rotation : clockwise-viewed from drive side

For Test Condition see
 Microfiche No.WP-210(N16)

Pre-stroke : - mm

1. Setting	Pump speed (rpm)	Settings	Charge air press(mmHg)	Difference in delivery(cc)
1-1 Timing device travel	1,200	2.4~3.0 (mm)		
1-2 Supply pump pressure	1,800	5.7~6.3 (kg/cm ²)		
1-3 Full load delivery without charge air pressure	1,200	29.6~30.6 (cc/1,000st)		2.5
Full load delivery with charge air pressure		(cc/1,000st)		
1-4 Idle speed regulation	350	6.7~9.7 (cc/1,000st)		3.0
1-5 Start	100	48~58 (cc/1,000st)		
1-6 Full-load speed regulation	2,700	7.0~13.0 (cc/1,000st)		
1-7				
1-8				

2. Test Specifications

2-1 Timing device	N = rpm mm	1,200 2.3~3.1	1,800 4.8~6.0	2,300 7.7~8.6
2-2 Supply pump	N = rpm kg/cm ²	800 3.3~4.1	1,800 5.6~6.4	2,500 7.1~7.9
2-3 Overflow delivery	N = rpm cc/10s	1,000 53.0~97.0		

2-4 Fuel injection quantities

Speed control lever position	Pump speed (rpm)	Fuel delivery (cc/1,000st)	Charge air press(mmHg)	Difference in delivery(cc)
Full speed position	1,200	29.1~31.1		
	600	21.4~25.4		
	2,300	25.3~29.3		
	2,700	6.5~13.5		
	2,800	Below 5		
Switch OFF	350	0		
Idling position	350	6.2~10.2		
	500	Below 4		
Partial load	900	8.1~18.1		
2-5 Solenoid	Max.cut-in voltage : 8 V Test voltage : 12~14 V			

3. Dimensions

K	3.2~3.4	mm
KF	6.54~6.74	mm
MS	1.7~1.9	mm
BCS	-	mm

Control lever angle

α	21.0~29.0	deg
A	2.5~8.0	mm
β	39.0~49.0	deg
B	11.0~16.0	mm
γ	10.5~11.5	deg
C	6.7~7.3	mm

Starting Injection Quantity Adjustment

Adjust the starting injection quantity (item 1/5) using the adjusting bolt (as shown in the figure at right).

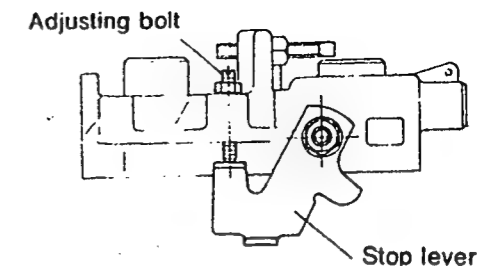

INJ. PUMP CALIBRATION DATA

Distributor-type

TEST OIL:
I S O 4113 or
S A E J967d

ENGINE MODEL : LD28

BOSCH No.9 460 610 167
DKKC No. 104760-2263
Date : 20.Nov.1986 2
Company : NISSAN
No. 16700 28L70

104760-2263

Injection pump No: 104660-2183 (NP-VE6/10F2500RNP1)

Pump rotation : clockwise-viewed from drive side

For Test Condition see
Microfiche No.WP-210(N16)

Pre-stroke : - mm

1. Setting	Pump speed (rpm)	Settings	Charge air press(mmHg)	Difference in delivery(cc)
1-1 Timing device travel	1,200	2.4~ 3.0 (mm)		
1-2 Supply pump pressure	1,800	5.7~ 6.3 (kg/cm ²)		
1-3 Full load delivery without charge air pressure	1,200	33.8~34.8 (cc/1,000st)		2.5
Full load delivery with charge air pressure		(cc/1,000st)		
1-4 Idle speed regulation	350	6.7~ 9.7 (cc/1,000st)		3.0
1-5 Start	100	48.0~58.0 (cc/1,000st)		
1-6 Full-load speed regulation	2,700	7.0~13.0 (cc/1,000st)		
1-7				
1-8				

2. Test Specifications

2-1 Timing device	N = rpm	1,200	1,800	2,300
	mm	2.3~ 3.1	4.8~ 6.0	7.7~ 8.6
2-2 Supply pump	N = rpm	800	1,800	2,500
	kg/cm ²	3.3~ 4.1	5.6~ 6.4	7.1~ 7.9
2-3 Overflow delivery	N = rpm	1,000		
	cc/10s	53.0~97.0		

2-4 Fuel injection quantities

Speed control lever position	Pump speed (rpm)	Fuel delivery (cc/1,000st)	Charge air press(mmHg)	Difference in delivery(cc)
Full speed position	1,200	33.3~35.3		
	600	27.0~31.0		
	2,300	28.4~32.4		
	2,700	6.5~13.5		
	2,800	Below 5		
Switch OFF	350	0		
Idling position	350	6.2~10.2		
	500	Below 4		
Partial load	900	12.0~22.0		
2-5 Solenoid	Max.cut-in voltage : 8 V Test voltage : 12~14 V			

3. Dimensions

K	3.2~3.4	mm
KF	6.54~6.74	mm
MS	1.7~1.9	mm
BCS	-	mm

Control lever angle

α	21.0~29.0	deg
A	2.5~ 8.0	mm
β	39.0~49.0	deg
B	11.0~16.0	mm
γ	10.5~11.5	deg
C	6.7~ 7.3	mm

Starting Injection Quantity Adjustment

Adjust the starting injection quantity (item 1/5) using the adjusting bolt (as shown in the figure at right).

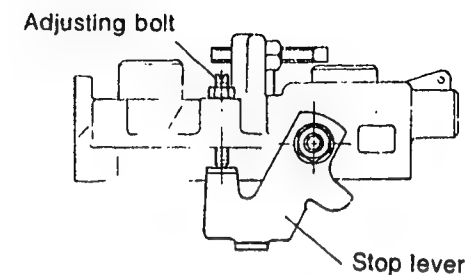

INJ. PUMP CALIBRATION DATA

TEST OIL:
I S O 4113 or
S A E J967d

Distributor—type

ENGINE MODEL : LD28

Injection pump No: 104669-2023 (NP-VE6/9F2500RNP21)

BOSCH No.9 460 610 092

DKKC No. 104769-2023

Date : 20.Nov.1986 [3]

Company : NISSAN

No. 16700 V5700

Pump rotation : clockwise-viewed from drive side

For Test Condition see
Microfiche No.WP-210(N16)

Pre-stroke : — mm

1. Setting	Pump speed (rpm)	Settings	Difference in delivery(cc)
1-1 Timing device travel	900	T=2.0~2.6 (mm)	2.5
1-2 Supply pump pressure	900	3.5~ 4.1 (kg/cm ²)	
1-3 Full load delivery	900	29.0~30.0 (cc/1,000st)	
1-4 Idle speed regulation	350	6.3~ 9.3 (cc/1,000st)	
1-5 Start	100	40.8~48.8 (cc/1,000st)	
1-6 Full-load speed regulation	2,600	15.5~21.5 (cc/1,000st)	
1-7 Load Timer Adjustment	900	T=0.5±0.3 (mm) (8.0~10.0 cc/1,000st)	
1-8			

2. Test Specifications

2-1 Timing device	N = rpm	900	1,200	2,500
	mm	1.9~ 2.7	3.6~ 4.8	8.1~ 9.0
2-2 Supply pump	N = rpm	900	1,800	2,500
	kg/cm ²	3.4~ 4.2	5.6~ 6.4	7.1~ 7.9
2-3 Overflow delivery	N = rpm	1,000		
	cc/10s	53.0~97.0		
2-4 Fuel deliveries				
Speed control lever	Pump speed (rpm)	Fuel delivery (cc/1,000st)		Difference in delivery
End stop	900	28.5~30.5		
	600	26.6~31.0		
	2,300	28.1~32.8		
	2,600	15.0~22.0		
	2,800	Below 5.0		
Switch OFF	350	0		
Idle stop	350	5.8~ 9.8		2.5
	500	Below 4.0		
Partial load	900	4.5~14.5		
2-5 Solenoid	Voltage : 12 V			

3. Dimensions

K	3.2 ~3.4	mm
KF	6.54~6.74	mm
MS	1.7 ~1.9	mm
BCS	—	mm

Control lever angle

α	21.0~29.0	deg
A	2.5~ 8.0	mm
β	39.0~49.0	deg
B	11.0~16.0	mm
γ	10.5~11.5	deg
C	6.7~ 7.3	mm

**Adjustment of the Stop lever start Q'ty **

Tighten the Adjusting bolt for the Start Q'ty of the Stop lever.

Adjust it so that the amount of start injection is in the range specified (page 1/4)

Adjustment of W-CSD (Check point)				
Timer stroke	Water Temperature °C	rpm	mm	basic
	50		0	
	20 ^{+0.5°}		0.55 ±0.2	basic
	-10		(i.65)	
F.I.C.D Lever angle	Water Temperature °C	rpm	deg	
	50		0	
	20 ^{+0.5°}		2 ^{+0.5°}	basic
	-10		(6)	

Adjustment of the W-CSD.

- 1) Adjusting timing device advance angle (refer to Fig.1.3.)
By means of the screw (1) adjust the timing device advance angle so that the value of timing device travel is that from the graph in fig 3 .

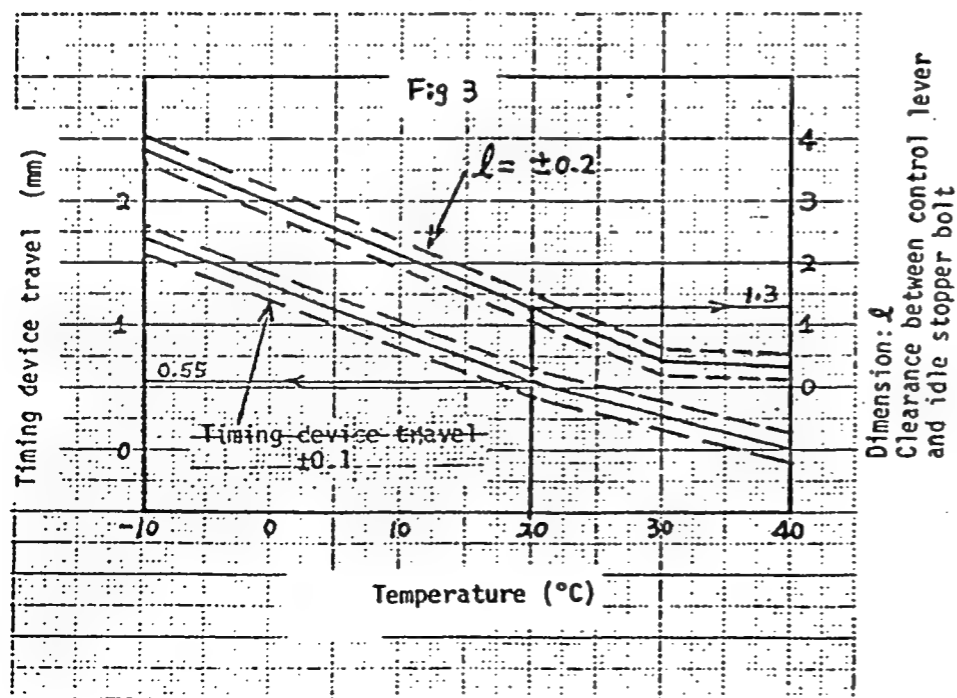
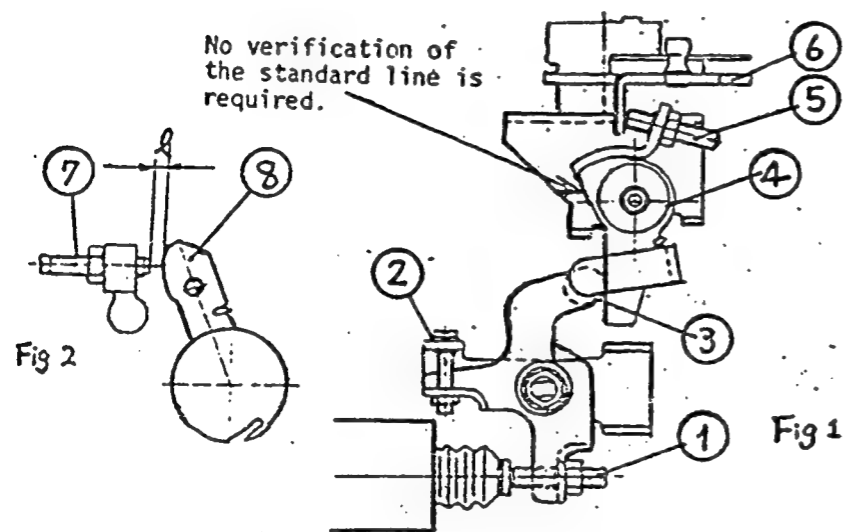

- 2) Setting intermediate lever position (refer to figs 1 and 2.)

Insert the thickness gauge $l = 1.3 \pm 0.05$ mm between the idle set screw (7) and the control lever (8). When the top edge of the roller of the intermediate lever (4) is positioned at from the top edge of the bracket, tighten the screw (5) temporarily so that it contacts the control lever (6).

- 3) Adjustment of the W-CSD lever (refer to Figs 1 and 2.)

Insert the thickness gauge $l \pm 0.05$ obtained from the graph in Fig 3 between the idle set screw (7) and the control lever (8) and tighten the screw (2) at the position where the roller of the W-CSD lever (3) contacts the intermediate lever (4).

(The temperature of WAX should be less than 30°C during adjustment.)

NOTE:

When inserting the thickness gauge allow a gap between the lever (3) and (4) by means of the screw (2) so that the levers from much force.

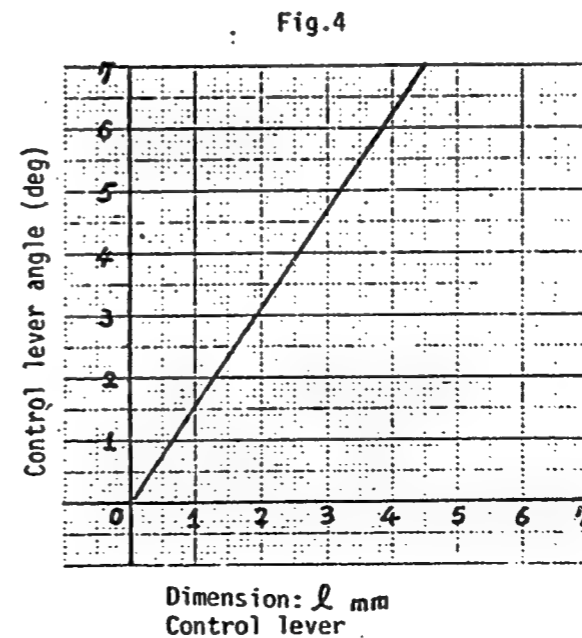

- 4) W-CSD specification for control lever angle refer to Fig 4.
Dimension = l mm

INJ. PUMP CALIBRATION DATA

1/4

104769-2025 2/4

TEST OIL:
ISO 4113 or
SAE J967d

Distributor—type

ENGINE MODEL : LD28

BOSCH No.9 460 610 159

DKKC No. 104769-2025

Date : 20.Nov.1986

Company : NISSAN

No. 16700 V5700

Injection pump No: 104669-2025 [NP-VE6/9F2500RNP21]

Pump rotation : clockwise-viewed from drive side

For Test Condition see
Microfiche No.WP-210(N16)

Pre-stroke : - mm

1. Setting	Pump speed (rpm)	Settings	Difference in delivery(cc)
1-1 Timing device travel	900	T=2.0~ 2.6 (mm)	2.5
1-2 Supply pump pressure	900	3.5~ 4.1 (kg/cm ²)	
1-3 Full load delivery	900	29.0~30.0 (cc/1,000st)	
1-4 Idle speed regulation	350	6.3~ 9.3 (cc/1,000st)	
1-5 Start	100	40.8~48.8 (cc/1,000st)	
1-6 Full-load speed regulation	2,600	15.5~21.5 (cc/1,000st)	
1-7 Load Timer Adjustment	900	T-0.2~0.8 (mm) (8.0~10.0 cc/1,000st)	
1-8			

2. Test Specifications

2-1 Timing device	N = rpm mm	900 1.9~ 2.7	1,200 3.5~ 4.7	2,500 8.1~ 9.0
2-2 Supply pump	N = rpm kg/cm ²	900 3.4~ 4.2	1,800 5.6~ 6.4	2,500 7.1~ 7.9
2-3 Overflow delivery	N = rpm cc/10s	900 43.0~87.0		

2-4 Fuel deliveries

Speed control lever	Pump speed (rpm)	Fuel delivery (cc/1,000st)	Difference in delivery
End stop	900	28.5~30.5	
	600	27.0~31.0	
	2,300	28.8~32.8	
	2,600	15.0~22.0	
	2,800	Below 5.0	
Switch OFF	350	0	
Idle stop	350	5.8~ 9.8	2.5
	500	Below 4.0	
Partial load	900	2.1~12.1	
2-5 Solenoid	Voltage : 12 V		

3. Dimensions

K	3.2 ~3.4	mm
KF	6.54~6.74	mm
MS	1.7 ~1.9	mm
BCS	—	mm

Control lever angle

α	21.0~29.0	deg
A	2.5~ 8.0	mm
β	39.0~49.0	deg
B	11.0~16.0	mm
γ	10.5~11.5	deg
C	6.7~ 7.3	mm

****Adjustment of the Stop lever start Q'ty ****

Tighten the Adjusting bolt for the Start Q'ty of the Stop lever.

Adjust it so that the amount of start injection is in the range specified (page 1/4)

Adjustment of W-CSD (Check point)				
Timer stroke	Water Temperature °C	rpm	mm	basic
	50		0	
	20 ^{+0.5°}		0.55 ±0.2	basic
	-10		(1.65)	
F.I.C.D Lever angle	Water Temperature °C	rpm	deg	
	50		0	
	20 ^{+0.5°}		2 ^{+0.5°}	basic
			(6)	

Adjustment of the W-CSD.

- 1) Adjusting timing device advance angle (refer to Fig.1.3.)
By means of the screw (1) adjust the timing device advance angle so that the value of timing device travel is that from the graph in fig 3 .

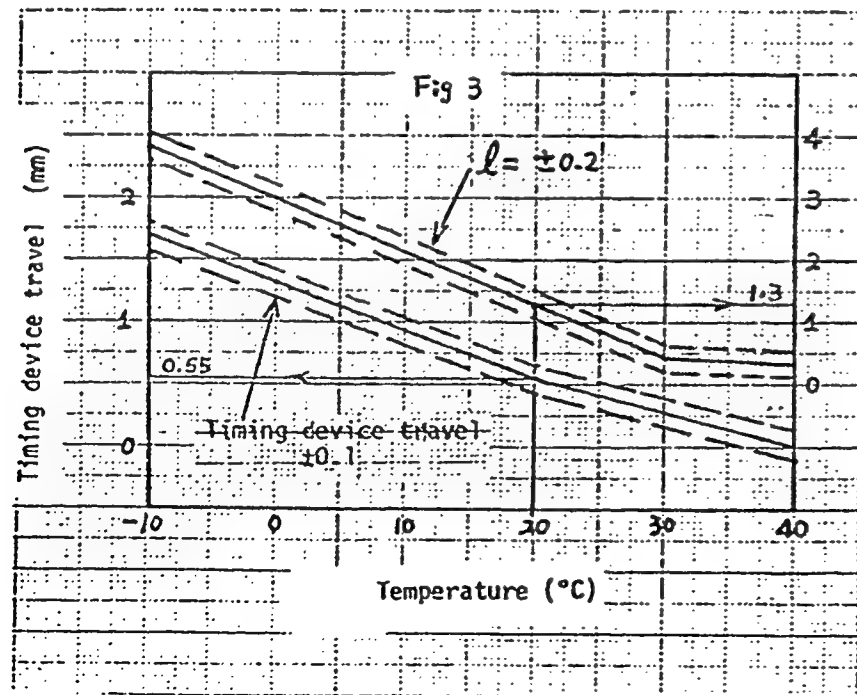
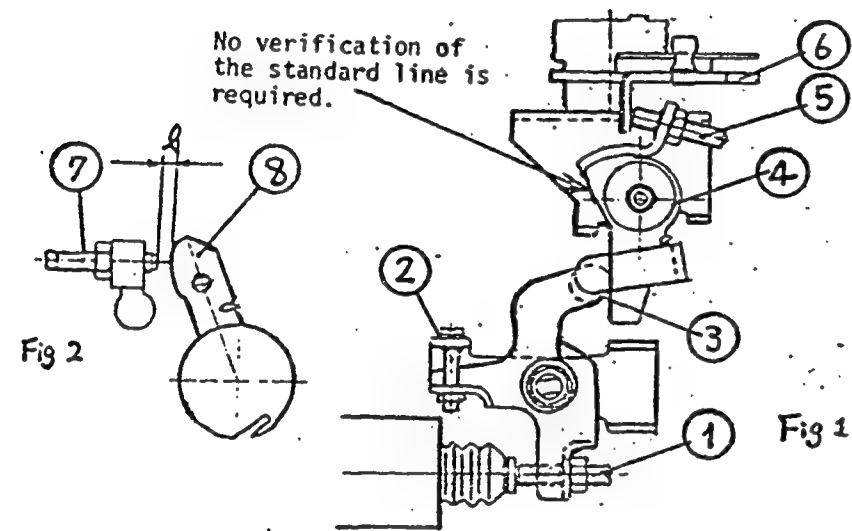

Dimension: l
Clearance between control lever
and idle stopper bolt

- 2) Setting intermediate lever position (refer to figs 1 and 2.)

Insert the thickness gauge $l = 1.3 \pm 0.05$ mm between the idle set screw (7) and the control lever (8). When the top edge of the roller of the intermediate lever (4) is positioned at from the top edge of the bracket, tighten the screw (5) temporarily so that it contacts the control lever (6).

- 3) Adjustment of the W-CSD lever (refer to Figs 1 and 2.)

Insert the thickness gauge $l \pm 0.05$ obtained from the graph in Fig 3 between the idle set screw (7) and the control lever (6) and tighten the screw (2) at the position where the roller of the W-CSD lever (3) contacts the intermediate lever (4).
(The temperature of WAX should be less than 30°C during adjustment.)

NOTE:
When inserting the thickness gauge allow a gap between the lever (3) and (4) by means of the screw (2) so that the levers from much force.

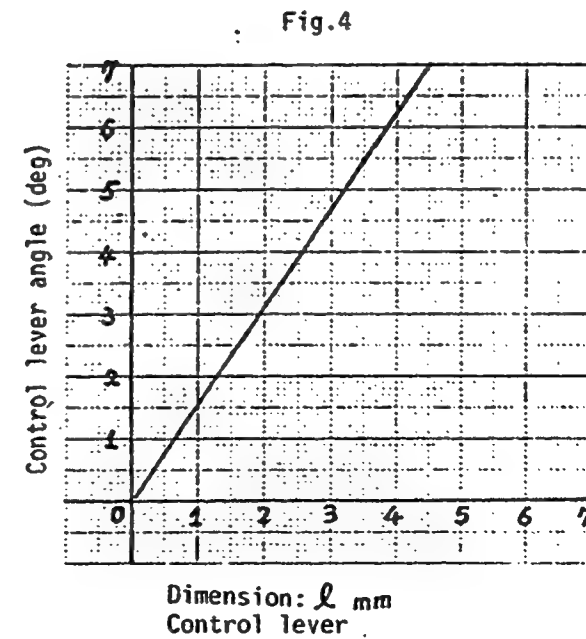

4) W-CSD specification
For control lever angle refer to Fig 4.
Dimension = l mm

Angle = $1.5714 l$

INJ. PUMP CALIBRATION DATA

TEST OIL:
ISO 4113 or
SAE J967d

Distributor-type
ENGINE MODEL : LD28

BOSCH No.9 460 610 160
DKKC No. 104769-2061
Date: 20.Nov.1986
Company: NISSAN
No. 16700 50L00

Injection pump No: 104669-2061 [NP-VE6/9F2500RNP37]

Pump rotation : clockwise-viewed from drive side
Pre-stroke : — mm

For Test Condition see
Microfiche No.WP-210(N16)

1. Setting	Pump speed (rpm)	Settings	Difference in delivery(cc)
1-1 Timing device travel	900	T=2.0~ 2.6 (mm)	2.5
1-2 Supply pump pressure	900	3.5~ 4.1 (kg/cm ²)	
1-3 Full load delivery	900	29.0~30.0 (cc/1,000st)	
1-4 Idle speed regulation	350	6.3~ 9.3 (cc/1,000st)	
1-5 Start	100	40.8~48.8 (cc/1,000st)	
1-6 Full-load speed regulation	2,600	15.5~21.5 (cc/1,000st)	
1-7 Load Timer Adjustment	900	T-0.2~0.8 (mm) (8.0~10.0 cc/1,000st)	
1-8			

2. Test Specifications

2-1 Timing device	N = rpm	900	1,200	2,500
	mm	1.9~ 2.7	3.5~ 4.7	3.1~ 9.0
2-2 Supply pump	N = rpm	900	1,800	2,500
	kg/cm ²	3.4~ 4.2	5.6~ 6.4	7.1~ 7.9
2-3 Overflow delivery	N = rpm	900		
	cc/10s	43.0~87.0		
2-4 Fuel deliveries	Speed control lever	Pump speed (rpm)	Fuel delivery (cc/1,000st)	Difference in delivery
End stop		900	28.5~30.5	
		600	27.0~31.0	
		2,300	28.8~32.8	
		2,600	15.0~22.0	
		2,800	Below 5.0	
Switch OFF	350	0		
Idle stop	350	5.8~ 9.8	2.2	
	500	Below 4.0		
Partial load	900	2.1~12.1		
2-5 Solenoid	Voltage : 12 V			

3. Dimensions

K	3.2 ~3.4 mm
KF	6.54~6.74 mm
MS	1.7 ~1.9 mm
BCS	— mm

Control lever angle

α	21.0~29.0 deg
A	5.7~ 9.5 mm
β	39.0~49.0 deg
B	11.0~16.0 mm
γ	10.5~11.5 deg
C	4.8~ 5.2 mm

Adjustment of W-CSD (Check point)				
Timer stroke	Water Temperature °C	rpm	mm	basic
	50		0	
	20		0.55 ±0.2	basic
	-10		(1.65)	
F.I.C.D Lever angle	Water Temperature °C	rpm	mm	deg
	50		0	0
	20 ^{+0.5°}		0.9 ±0.2	2 ±0.5
	-10		2.8	6

Adjustment of stop lever bolt to obtain adequate fuel delivery for engine starting.

Adjust the bolt shown in below picture and get fuel delivery as specified for engine starting and then fix bolt tightly.

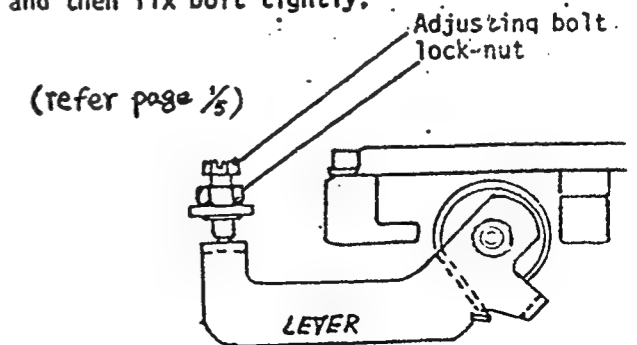

Adjustment of the W-CSD.

- 1) Adjusting timing device advance angle (refer to Fig.1.3.)
By means of the screw (1) adjust the timing device advance angle so that the value of timing device travel is that from the graph in fig 3 .

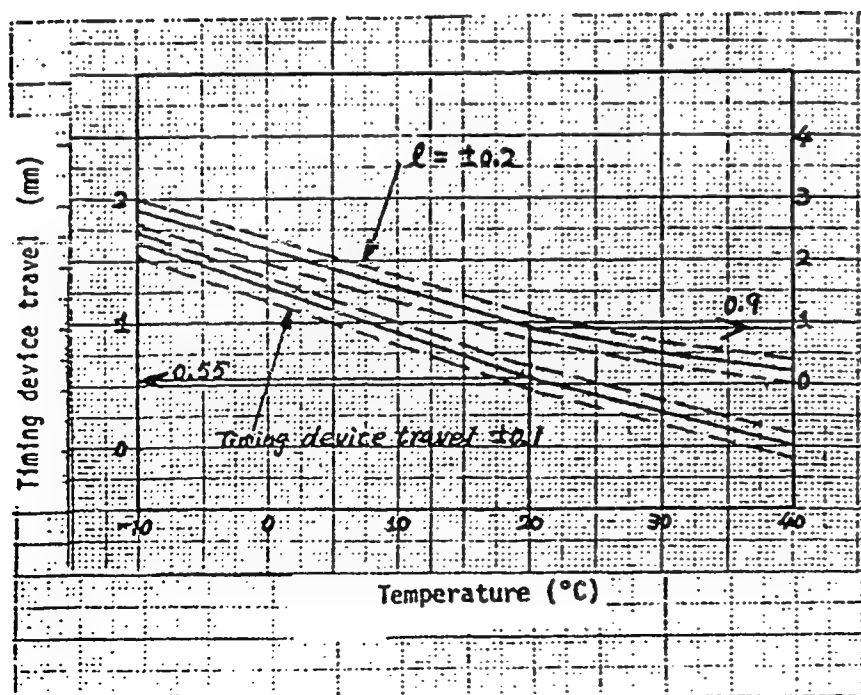
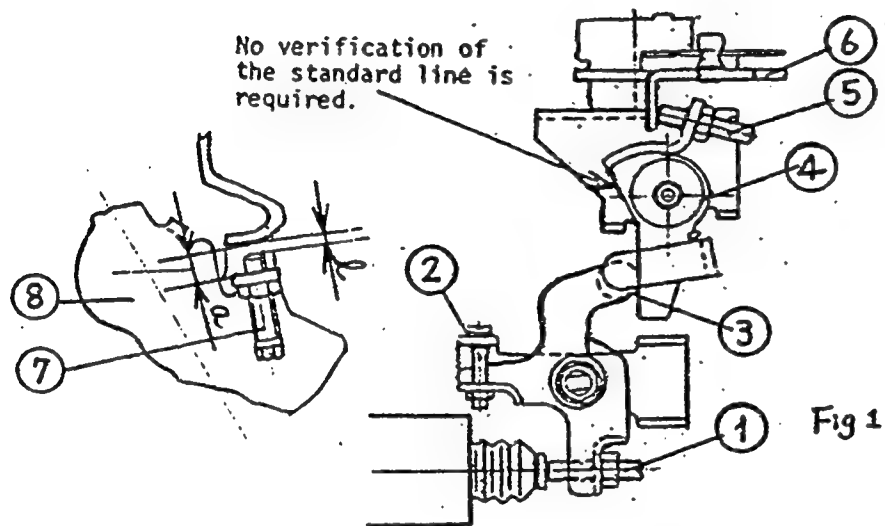

Dimension: l
Clearance between control lever
and idle stopper bolt

- 2) Setting intermediate lever position (refer to figs 1 and 2.)

Insert the thickness gauge $l = 0.9 \pm 0.05$ mm between the idle set screw (7) and the control lever (8). When the top edge of the roller of the intermediate lever (4) is positioned at from the top edge of the bracket, tighten the screw (5) temporarily so that it contacts the control lever (6).

- 3) Adjustment of the W-CSD lever (refer to Figs 1 and 2.)

Insert the thickness gauge $l \pm 0.05$ obtained from the graph in Fig 3 between the idle set screw (7) and the control lever (6) and tighten the screw (2) at the position where the roller of the W-CSD lever (3) contacts the intermediate lever (4).

(The temperature of WAX should be less than 30°C during adjustment.)

NOTE:
When inserting the thickness gauge allow a gap between the lever (3) and (4) by means of the screw (2) so that the levers from much force.

Fig.4

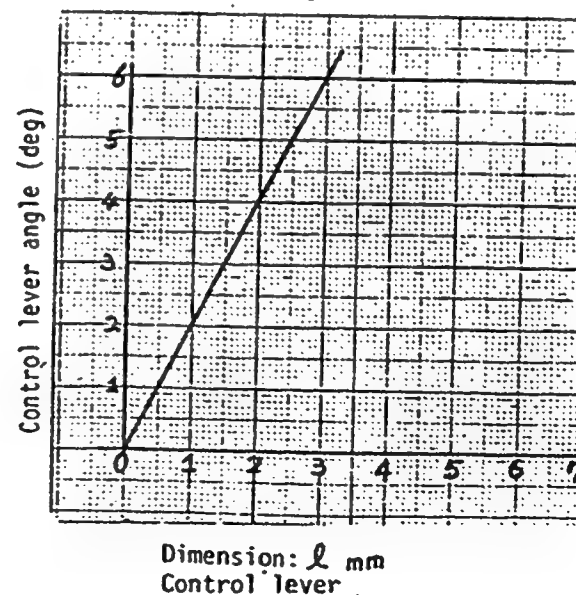

- 4) W-CSD specification
For control lever angle refer to Fig 4.

Dimension = l mm

Angle: $2.2 l$

Dash-Pot Adjustment

Insert the Block gauge $l = 3.4^{+0.05}$ mm between idle set screw (3) and bracket (4).

Adjust the Dash-Pot adjusting screw (1) to touch the push-rod (5), then tighten the lock-nut (2).

Note: Tightening torque: $T=0.6$ to 0.7 Kg-m

A:Check: Alignment between adjusting screw (1) and push rod (5).

B: Control lever must return to the idle position smoothly.

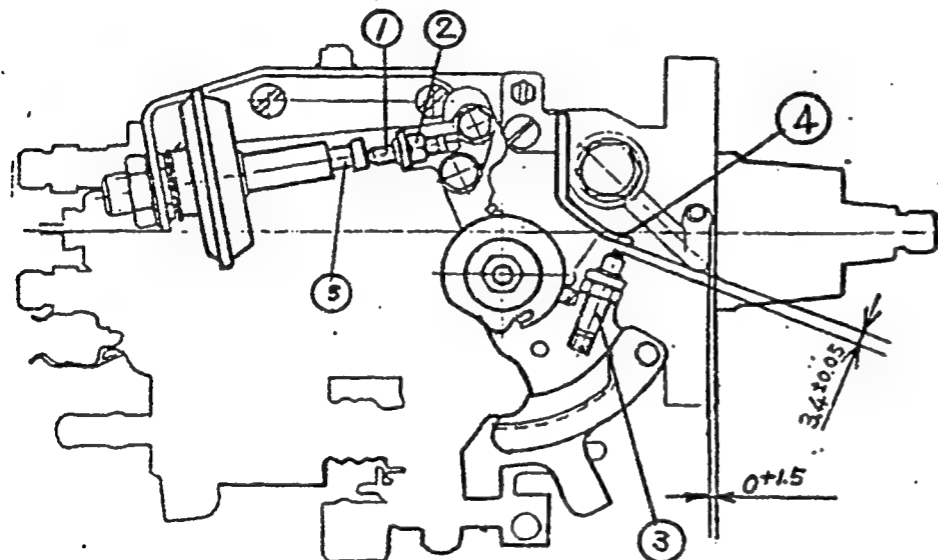

INJ. PUMP CALIBRATION DATA

Distributor-type

ENGINE MODEL : LD28

TEST OIL:
ISO 4113 or
SAE J967d

Injection pump No: 104669-2081 (NP-VE6/9F2500RNP34)

BOSCH No.9 460 610 161
DKKC No. 104769-2071
Date: 20.Nov.1986
Company: NISSAN
No. 16700 50L10

1/4

104769-2071 2/4

Pump rotation : clockwise-viewed from drive side
Pre-stroke : - mm

For Test Condition see
Microfiche No.WP-210(N16)

1. Setting	Pump speed (rpm)	Settings	Difference in delivery(cc)
1-1 Timing device travel	900	T=2.0~ 2.6 (mm)	2.5
1-2 Supply pump pressure	900	3.5~ 4.1 (kg/cm ²)	
1-3 Full load delivery	900	29.0~30.0 (cc/1,000st)	
1-4 Idle speed regulation	350	6.3~ 9.3 (cc/1,000st)	
1-5 Start	100	40.8~48.8 (cc/1,000st)	
1-6 Full-load speed regulation	2,600	15.5~21.5 (cc/1,000st)	
1-7 Load Timer Adjustment	900	T=0.2~0.8 (mm) (8.0~10.0 cc/1,000st)	
1-8			

2. Test Specifications

2-1 Timing device	N = rpm mm	900 1.9~ 2.7	1,200 3.5~ 4.7	2,500 8.1~ 9.0
2-2 Supply pump	N = rpm kg/cm ²	900 3.4~ 4.2	1,800 5.6~ 6.4	2,500 7.1~ 7.9
2-3 Overflow delivery	N = rpm cc/10s	900 43.0~87.0		
2-4 Fuel deliveries				
Speed control lever	Pump speed (rpm)	Fuel delivery (cc/1,000st)		Difference in delivery
End stop	900	28.5~30.5		
	600	27.0~31.0		
	2,300	28.8~32.8		
	2,600	15.0~22.0		
	2,800	Below 5.0		
Switch OFF	350	0		
Idle stop	350	5.8~ 9.8		2.2
	500	Below 4.0		
Partial load	900	2.1~12.1		
2-5 Solenoid	Voltage : 12 V			

3. Dimensions

K	3.2 ~3.4	mm
KF	6.54~6.74	mm
MS	1.7 ~1.9	mm
BCS	—	mm

Control lever angle

α	21.0~29.0	deg
A	5.7~ 9.5	mm
β	39.0~49.0	deg
B	11.0~16.0	mm
γ	10.5~11.5	deg
C	4.8~ 5.2	mm

Adjustment of W-CSD (Check point)				
Timer stroke	Water Temperature °C	rpm	mm	basic
	50		0	
	20		0.55 ±0.2	basic
	-10		(i.65)	
F.I.C.D Lever angle	Water Temperature °C	rpm	mm	deg
	50		0	0
	20 ^{+0.5°}		0.9 ^{±0.2}	2 ^{±0.5}
	-10		2.8	6

Adjustment of stop lever bolt to obtain adequate fuel delivery for engine starting.

Adjust the bolt shown in below picture and get fuel delivery as specified for engine starting and then fix bolt tightly.

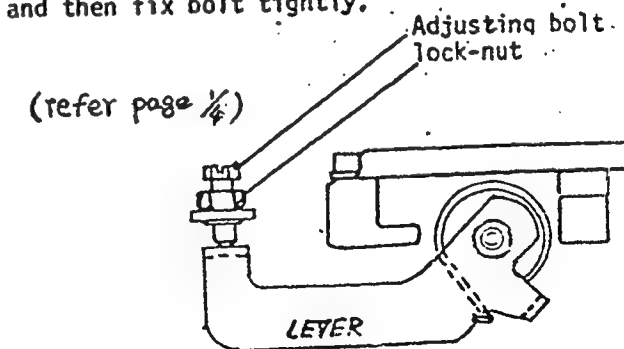

104769-2071 3/4

Adjustment of the W-CSD.

- 1) Adjusting timing device advance angle (refer to Fig.1.3.)
By means of the screw (1) adjust the timing device advance angle so that the value of timing device travel is that from the graph in fig 3.

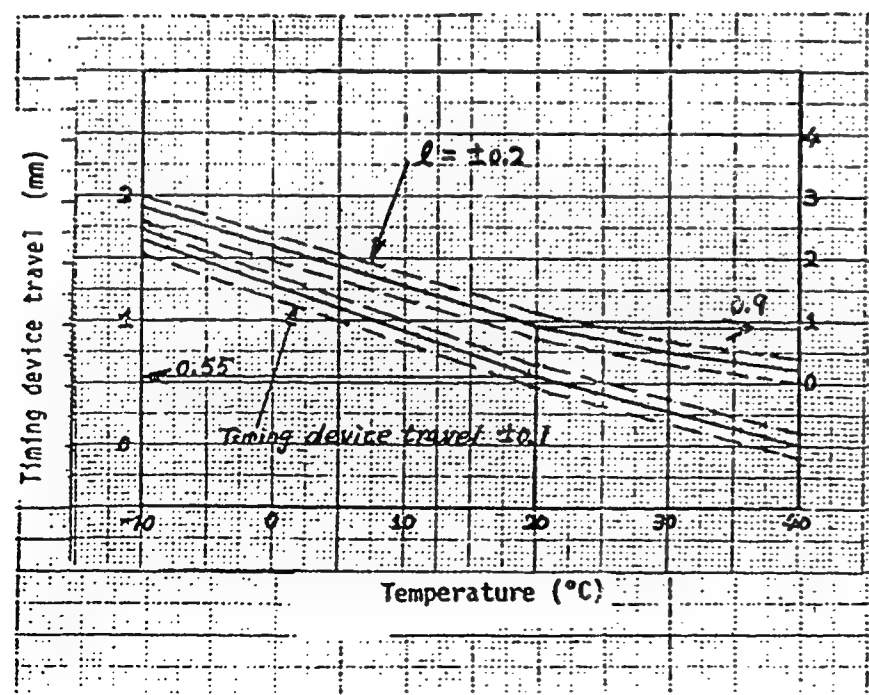
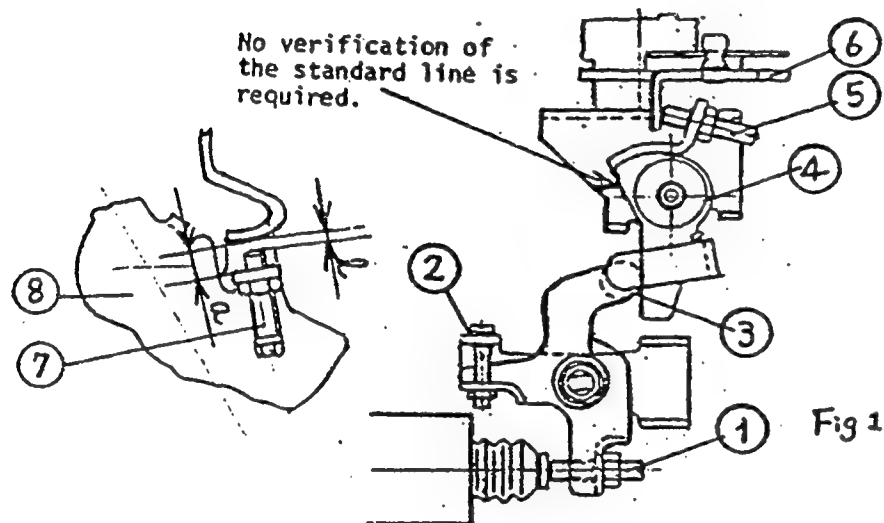

- 2) Setting intermediate lever position (refer to figs 1 and 2.)

Insert the thickness gauge $l = 0.9 \pm 0.05$ mm between the idle set screw (7) and the control lever (8). When the top edge of the roller of the intermediate lever (4) is positioned at from the top edge of the bracket, tighten the screw (5) temporarily so that it contacts the control lever (6).

- 3) Adjustment of the W-CSD lever (refer to Figs 1 and 2.)

Insert the thickness gauge $l \pm 0.05$ obtained from the graph in Fig 3 between the idle set screw (7) and the control lever (6) and tighten the screw (2) at the position where the roller of the W-CSD lever (3) contacts the intermediate lever (4).

(The temperature of WAX should be less than 30°C during adjustment.)

NOTE:
When inserting the thickness gauge allow a gap between the lever (3) and (4) by means of the screw (2) so that the levers from much force.

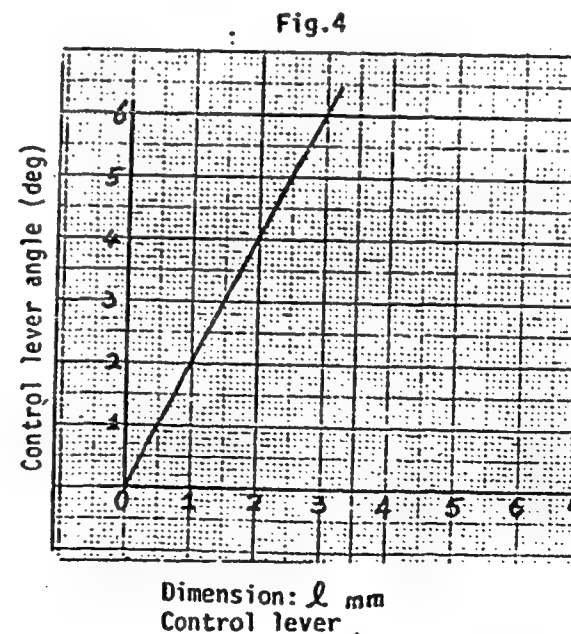

- 4) W-CSD specification
For control lever angle refer to Fig 4.
Dimension = l mm

Angle: $2.2 l$

INJ.PUMP CALIBRATION DATA

TEST OIL:
ISO 4113 or
SAE J967d

Distributor-type

ENGINE MODEL : RD28

Injection pump No: 104669-2111 (NP-VE6/9F2500RNP40)

BOSCH No.9 460 610 200

DKKC No. 104769-2103

Date: 20.Nov.1986

Company: NISSAN

No. 16700 V7212

104769-2103 2/4

Pump rotation : clockwise-viewed from drive side

Pre-stroke : mm

For Test Condition see
Microfiche No.WP-210(N16)

1. Setting	Pump speed (rpm)	Settings	Charge air press(mmHg)	Difference in delivery(cc)
1-1 Timing device travel	900	1.1~ 1.5 (mm)		
1-2 Supply pump pressure	900	3.5~ 4.1 (kg/cm ²)		
1-3 Full load delivery without charge air pressure	900	30.9~31.9 (cc/1,000st)		2.5
Full load delivery with charge air pressure		(cc/1,000st)		
1-4 Idle speed regulation	350	5.8~ 8.8 (cc/1,000st)		
1-5 Start	100	40.8~48.8 (cc/1,000st)		
1-6 Full-load speed regulation	2,600	15.5~21.5 (cc/1,000st)		
1-7				
1-8				

2. Test Specifications

2-1 Timing device	N = rpm	900	1,200	2,300
	mm	1.0~ 1.6	2.7~ 3.5	8.1~ 9.0
2-2 Supply pump	N = rpm	900	1,800	2,500
	kg/cm ²	3.4~ 4.2	5.6~ 6.4	7.1~ 7.9
2-3 Overflow delivery	N = rpm	900		
	cc/10s	43.0~87.0		

2-4 Fuel deliveries

Speed control lever	Pump speed (rpm)	Fuel delivery (cc/1,000st)	Charge air press(mmHg)	Difference in delivery
End stop	2,800	Below 5.0		
	2,600	15.0~22.0		
	2,300	27.1~31.1		
	900	30.4~32.4		
	600	29.1~33.1		

Switch OFF	350	0		
Idle stop	350	5.3~ 9.3		1.9
	500	Below 4.0		

Partial load	900	2.5~12.5		
--------------	-----	----------	--	--

2-5 Solenoid	Max.cut-in voltage : 8 V
	Test voltage : 12~14 V

3. Dimensions

K	3.2 ~3.4	mm
KF	6.54~6.74	mm
MS	1.7 ~1.9	mm
BCS	--	mm

Control lever angle

α	21.0~29.0	deg
A	7.6~11.7	mm
β	39.0~49.0	deg
B	11.9~15.6	mm
γ	10.5~11.5	deg
C	5.7~ 6.3	mm

OW-CSD Adjustment

1) Timer stroke adjustment

1. Calculate the timer stroke from Fig. 2 according to the atmospheric temperature at the time of adjustment.
2. Adjust using timer stroke adjusting screw so that the timer stroke is as calculated in Step 1.

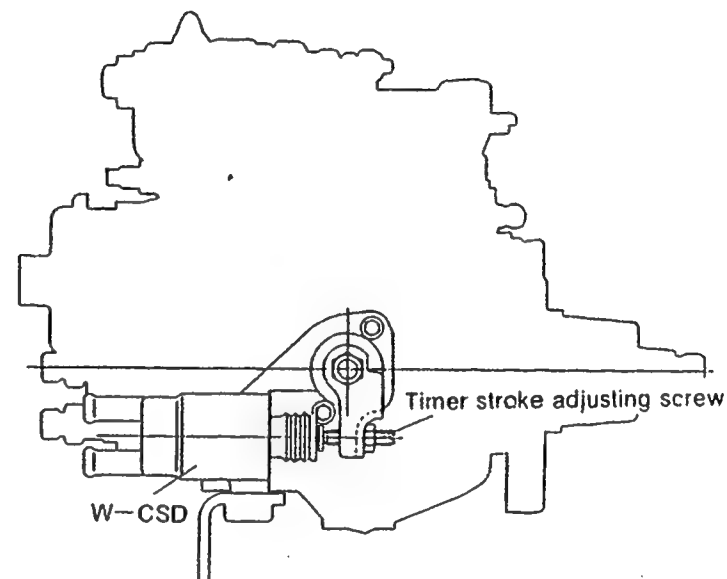

Fig. 1

Formula for calculating Fig. 2

Formula for calculating timer stroke: When $-10 \leq \theta \leq 20$ $TA = -0.0367\theta + 1.284$
When $20 \leq \theta \leq 40$ $TA = -0.0275\theta + 1.1$

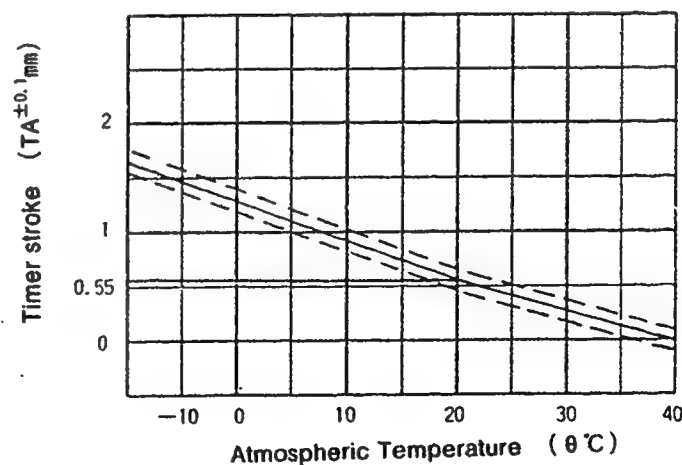
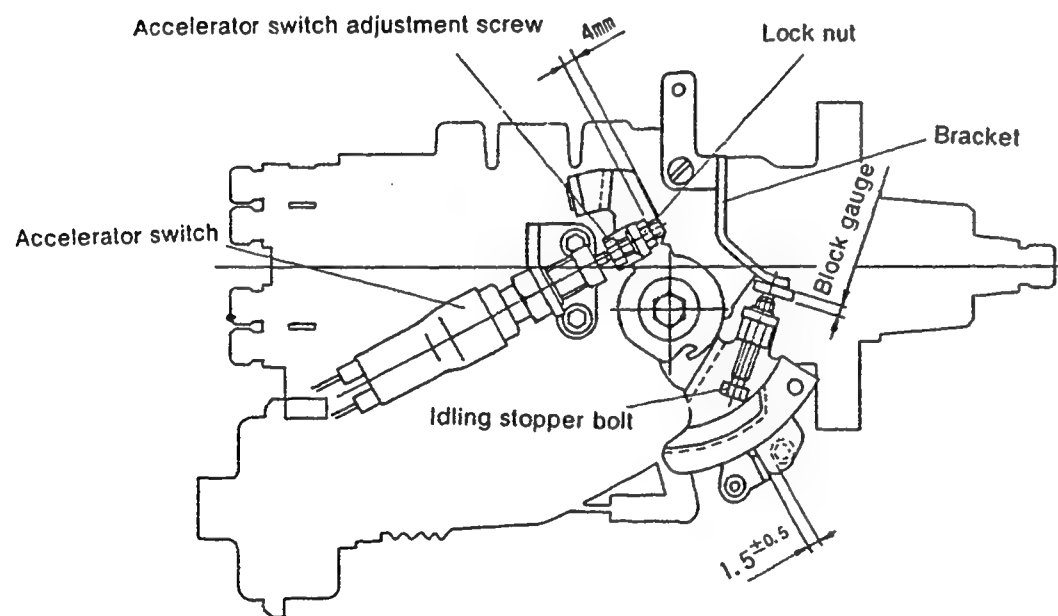

Fig. 2

Accelerator Switch Installation Adjustment

1. Adjust so that the accelerator switch adjustment screw protrudes 4mm from the locknut, and then lock in position.
2. Insert a block gauge (thickness gauge) of 2.5 ± 0.1 mm thickness between the idling stopper bolt and bracket.
3. With the control lever in the position described in Step 2, adjust the installation position of the accelerator switch, and set it so that it can change from ON to OFF.



○DASH POT ADJUSTMENT

- ① Insert a block gauge (thickness gauge) of thickness 3.8 ± 0.05 in the gap between the control lever and the bracket.
- ② With the control lever positioned as described in ① above, adjust the Dashpot adjusting screw so that the Dashpot adjusting screw and the push rod are in contact. Fix using the nut.

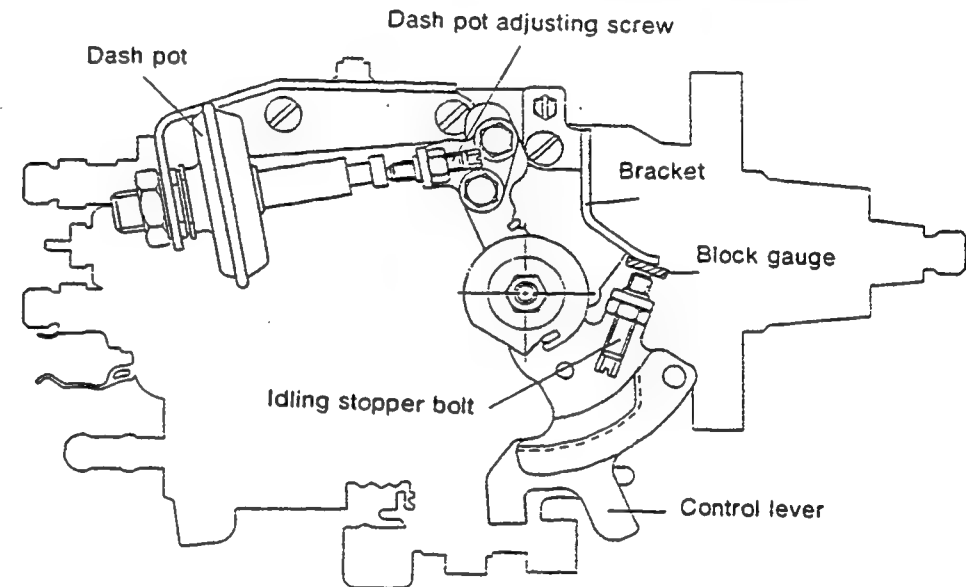

○ISC (Idle Speed Control) Actuator Mount

1. Hold the control lever in the idling position.
2. Adjust the position of the actuator bracket so that the gap between the control lever and the ISC lever roller is 1.5 ± 0.5 mm, and then fix the bracket in position.

○Starting Injection Quantity Adjustment.

Starting Injection Quantity (item 1 - 5) using the adjusting bolt (as shown in the figure at below).

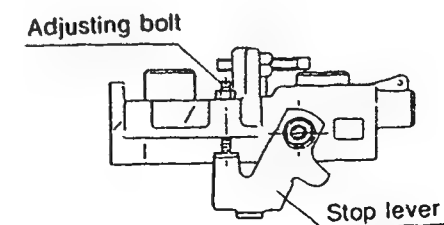

INJ. PUMP CALIBRATION DATA

TEST OIL:
ISO 4113 or
SAE J967d

Distributor-type

ENGINE MODEL : RD28

Injection pump No: 104669-2110 [NP-VE6/9F2500RNP40]

Pump rotation : clockwise-viewed from drive side

Pre-stroke : - mm

BOSCH No.9 460 610 162

DKKC No. 104769-2110

Date : 20.Nov.1986 ①

Company : NISSAN

No. 16700 V7202

For Test Condition see
Microfiche No.WP-210(N16)

104769-2110 2/3

1. Setting	Pump speed (rpm)	Settings	Charge air press(mmHg)	Difference in delivery(cc)
1-1 Timing device travel	900	1.1~ 1.5 (mm)		
1-2 Supply pump pressure	900	3.5~ 4.1 (kg/cm ²)		
1-3 Full load delivery without charge air pressure	900	30.9~31.9 (cc/1,000st)		2.5
Full load delivery with charge air pressure		(cc/1,000st)		
1-4 Idle speed regulation	350	5.8~ 8.8 (cc/1,000st)		
1-5 Start	100	40.8~48.8 (cc/1,000st)		
1-6 Full-load speed regulation	2,600	15.5~21.5 (cc/1,000st)		
1-7				
1-8				

2. Test Specifications

2-1 Timing device	N = rpm	900	1,200	2,300
	mm	1.0~ 1.6	2.7~ 3.5	8.1~ 9.0
2-2 Supply pump	N = rpm	900	1,800	2,500
	kg/cm ²	3.4~ 4.2	5.6~ 6.4	7.1~ 7.9
2-3 Overflow delivery	N = rpm	900		
	cc/10s	43.0~87.0		

2-4 Fuel deliveries	Speed control lever	Pump speed (rpm)	Fuel delivery (cc/1,000st)	Charge air press(mmHg)	Difference in delivery
End stop		900	30.4~32.4		
		600	29.1~33.1		
		2,300	27.1~31.1		
		2,600	15.0~22.0		
		2,800	Below 5.0		
Switch OFF		350	0		
Idle stop		350	5.3~9.3		1.6
		500	Below 4.0		
Partial load		900	2.5~12.5		
2-5 Solenoid	Max.cut-in voltage : 8 V				
	Test voltage : 12~14 V				

3. Dimensions

K	3.2 ~3.4	mm
KF	6.54~6.74	mm
MS	1.7 ~1.9	mm
BCS	-	mm

Control lever angle

α	21.0~29.0	deg
A	7.6~11.7	mm
β	39.0~49.0	deg
B	11.9~15.6	mm
γ	10.5~11.5	deg
C	5.7~ 6.3	mm

○W-CSD Adjustment

1) Timer stroke adjustment

1. Calculate the timer stroke from Fig. 2 according to the atmospheric temperature at the time of adjustment.
2. Adjust using timer stroke adjusting screw so that the timer stroke is as calculated in Step 1.

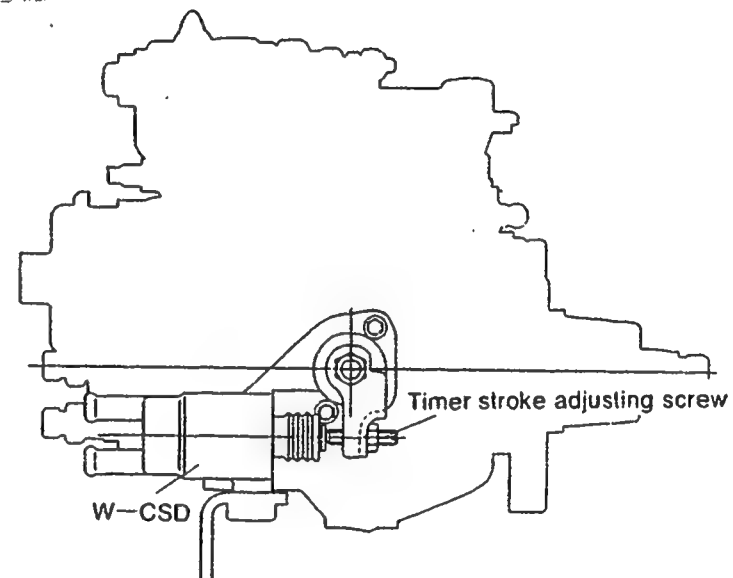

Fig. 1

Formula for calculating Fig. 2

Formula for calculating timer stroke:

When $-10 \leq \theta \leq 20$ $TA = -0.0367 \theta + 1.284$

When $20 \leq \theta \leq 40$ $TA = -0.0275 \theta + 1.1$

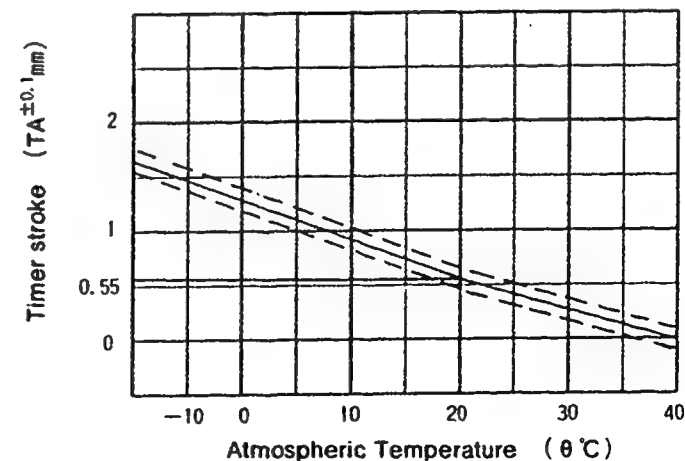
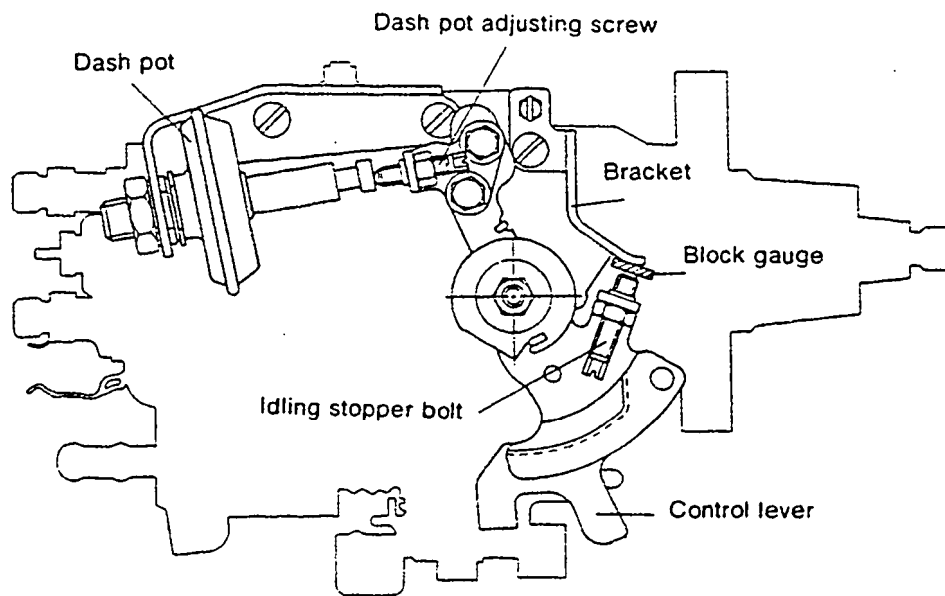

Fig. 2

104769-2110 3/3

○DASH POT ADJUSTMENT

- ① Insert a block gauge (thickness gauge) of thickness $3.8^{\pm 0.05}$ in the gap between the control lever and the bracket.
- ② With the control lever positioned as described in ① above, adjust the Dashpot adjusting screw so that the Dashpot adjusting screw and the push rod are in contact. Fix using the nut.



○ISC (Idle Speed Control) Actuator Mount

1. Hold the control lever in the idling position.
2. Adjust the position of the actuator bracket so that the gap between the control lever and the ISC lever roller is 1.5 ± 0.5 mm, and then fix the bracket in position.

○Starting Injection Quantity Adjustment.

Starting Injection Quantity (item 1 - 5) using the adjusting bolt (as shown in the figure at below).

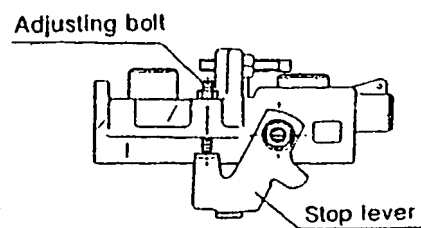

INJ. PUMP CALIBRATION DATA

Distributor-type

ENGINE MODEL : RD28

BOSCH No.9 460 610 201

DKKC No. 104769-2113

Date : 20.Nov.1986 ①

Company : NISSAN

No. 16700 V7203

104769-2113 2/3

TEST OIL:
ISO 4113 or
SAE J967d

Injection pump No: 104669-2111 (NP-VE6/9F2500RNP40)

Pump rotation : clockwise-viewed from drive side

For Test Condition see
Microfiche No.WP-210(N16)

Pre-stroke : - mm

1. Setting	Pump speed (rpm)	Settings	Charge air press(mmHg)	Difference in delivery(cc)
1-1 Timing device travel	900	1.1~ 1.5 (mm)		2.5
1-2 Supply pump pressure	900	3.5~ 4.1 (kg/cm ²)		
1-3 Full load delivery without charge air pressure	900	30.9~31.9 (cc/1,000st)		
		Full load delivery with charge air pressure		(cc/1,000st)
1-4 Idle speed regulation	350	5.8~ 8.8 (cc/1,000st)		
1-5 Start	100	40.8~48.8 (cc/1,000st)		
1-6 Full-load speed regulation	2,600	15.5~21.5 (cc/1,000st)		
1-7				
1-8				

2. Test Specifications

2-1 Timing device	N = rpm	900	1,200	2,300
	mm	1.0~ 1.6	2.7~ 3.5	8.1~ 9.0
2-2 Supply pump	N = rpm	900	1,800	2,500
	kg/cm ²	3.4~ 4.2	5.6~ 6.4	7.1~ 7.9
2-3 Overflow delivery	N = rpm	900		
	cc/10s	43.0~87.0		

2-4 Fuel deliveries

Speed control lever	Pump speed (rpm)	Fuel delivery (cc/1,000st)	Charge air press(mmHg)	Difference in delivery
End stop	2,800	Below 5.0		
	2,600	15.0~22.0		
	2,300	27.1~31.1		
	900	30.4~32.4		
	600	29.1~33.1		
Switch OFF	350	0		
Idle stop	350	5.3~ 9.3		1.4
	500	Below 4.0		
Partial load	900	2.5~12.5		

3. Dimensions

K	3.2 ~3.4	mm
KF	6.54~6.74	mm
MS	1.7 ~1.9	mm
BCS	-	mm

Control lever angle

α	21.0~29.0	deg
A	7.6~11.7	mm
β	39.0~49.0	deg
B	11.9~15.6	mm
γ	10.5~11.5	deg
C	5.7~ 6.3	mm

2-5 Solenoid Max.cut-in voltage : 8 V
Test voltage : 12~14 V

OW-CSD Adjustment

1) Timer stroke adjustment

1. Calculate the timer stroke from Fig. 2 according to the atmospheric temperature at the time of adjustment.
2. Adjust using timer stroke adjusting screw so that the timer stroke is as calculated in Step 1.

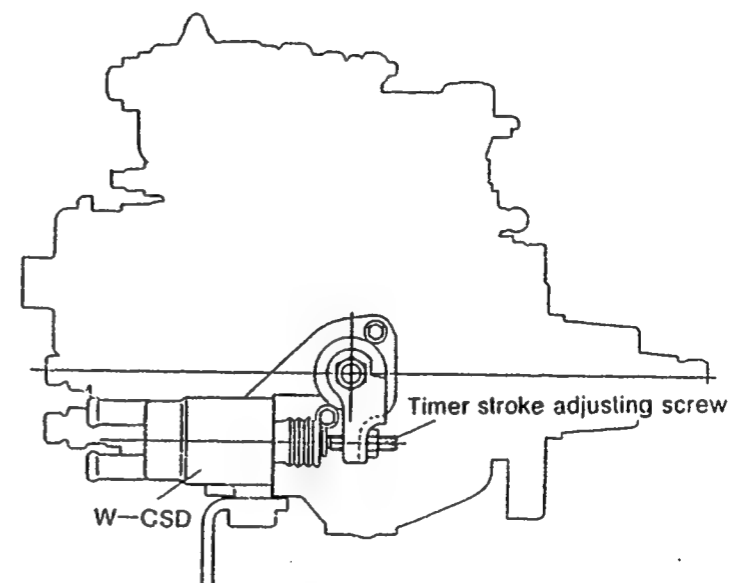

Fig. 1

Formula for calculating Fig. 2

Formula for calculating timer stroke:

$$\text{When } -10 \leq \theta \leq 20 \quad TA = -0.055\theta + 1.1$$

$$\text{When } 20 \leq \theta \leq 40 \quad TA = -0.0333\theta + 0.66$$

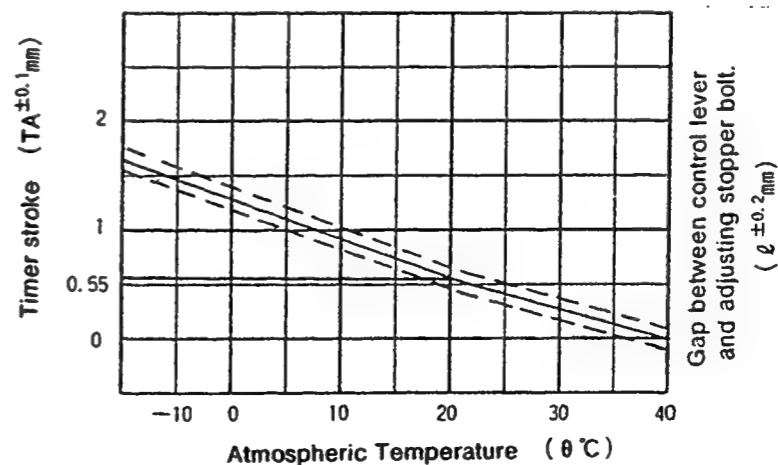
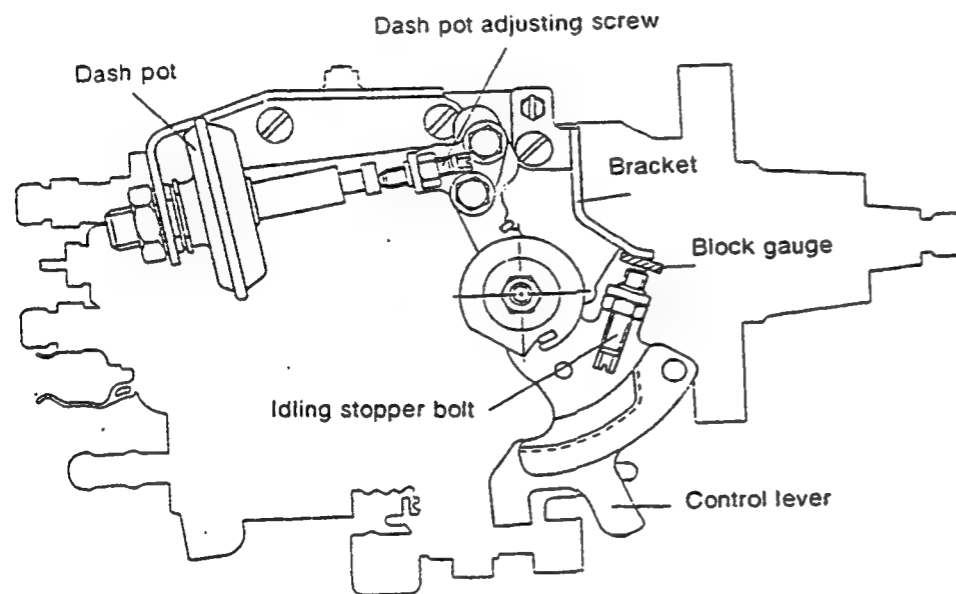

Fig. 2

○DASH POT ADJUSTMENT

- ① Insert a block gauge (thickness gauge) of thickness 3.8 ± 0.05 in the gap between the control lever and the bracket.
- ② With the control lever positioned as described in ① above, adjust the Dashpot adjusting screw so that the Dashpot adjusting screw and the push rod are in contact. Fix using the nut.



○ISC (Idle Speed Control) Actuator Mount

1. Hold the control lever in the idling position.
2. Adjust the position of the actuator bracket so that the gap between the control lever and the ISC lever roller is 1.5 ± 0.5 mm, and then fix the bracket in position.

○Starting Injection Quantity Adjustment.

Starting Injection Quantity (item 1 - 5) using the adjusting bolt (as shown in the figure at below) .

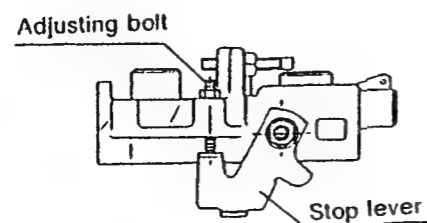

INJ. PUMP CALIBRATION DATA

Distributor-type

TEST OIL:
ISO 4113 or
SAE J967d

ENGINE MODEL : NEW HA

Injection pump No: 104640-0091 [NP-VE4/10F1900RNP51]

BOSCH No.9 460 610 094

DKKC No. 104740-0091

Date : 20.Nov.1986 1

Company : MAZDA

No. SE01 13 800A

Pump rotation : clockwise-viewed from drive side

For Test Condition see
Microfiche No.WP-210(N16)

Pre-stroke : 0.18~0.22 mm

1. Setting	Pump speed (rpm)	Settings	Charge air press(mmHg)	Difference in delivery(cc)
1-1 Timing device travel	1,500	5.0~ 5.4 (mm)		
1-2 Supply pump pressure	1,500	5.7~ 6.3 (kg/cm ²)		
1-3 Full load delivery without charge air pressure	1,000	53.9~54.9 (cc/1,000st)		3.5
Full load delivery with charge air pressure		(cc/1,000st)		
1-4 Idle speed regulation	350	10.0~14.0 (cc/1,000st)		2.5
1-5 Start	100	Above 78 (cc/1,000st)		
1-6 Full-load speed regulation	2,100	19.1~25.1 (cc/1,000st)		
1-7				
1-8				

2. Test Specifications

2-1 Timing device	N = rpm	1,000	1,500	1,900	
	mm	1.6~ 2.8	4.9~ 5.5	7.1~ 8.1	
2-2 Supply pump	N = rpm	500	1,500	1,800	
	kg/cm ²	2.3~ 2.9	5.7~ 6.3	6.7~ 7.3	
2-3 Overflow delivery	N = rpm	1,000			
	cc/10s	53.0~97.0			
2-4 Fuel injection quantities					
Speed control lever position	Pump speed (rpm)	Fuel delivery (cc/1,000st)	Charge air press(mmHg)	Difference in delivery(cc)	
Full speed position	1,000	53.4~55.4			
	500	46.1~50.1			
	1,900	46.2~50.2			
	2,100	19.1~25.1			
	2,200	Below 6			
Switch OFF	350	0			
Idling position	350	10.0~ 4.0			
	Below 620	0			
2-5 Solenoid					
	Max.cut-in voltage : 16 V				
	Test voltage : 24~26 V				

3. Dimensions

K	3.2~3.4	mm
KF	5.7~5.9	mm
MS	1.7~1.9	mm
BCS	—	mm

Control lever angle

α	16.0~24.0	deg
A		mm
β	33.0~43.0	deg
B		mm
γ	—	deg
C	—	mm

INJ. PUMP CALIBRATION DATA

Distributor-type

TEST OIL:
I S O 4113 or
S A E J967d

ENGINE MODEL : LD20T

BOSCH No.9 460 610 023

DKKC No. 104740-2000

Date : 20.Nov.1986 3

Company : NISSAN

No. 16700 W3400

104740-2000

Injection pump No: 104640-2000 [NP-VE4/10F2400RNP83]

Pump rotation : clockwise-viewed from drive side

For Test Condition see
Microfiche No.WP-210(N16)

Pre-stroke : - mm

1. Setting	Pump speed (rpm)	Settings	Charge air press(mmHg)	Difference in delivery(cc)
1-1 Timing device travel	900	2.2~ 2.8 (mm)	160~180	2.5
1-2 Supply pump pressure	900	2.9~ 3.5 (kg/cm ²)	160~180	
1-3 Full load delivery without charge air pressure	600	29.7~30.7 (cc/1,000st)		
Full load delivery with charge air pressure	900	36.9~37.9 (cc/1,000st)	160~180	3.0
1-4 Idle speed regulation	325	4.5~ 7.5 (cc/1,000st)		
1-5 Start	100	Above 40 (cc/1,000st)		
1-6 Full-load speed regulation	2,700	6.7~12.7 (cc/1,000st)	500~520	
1-7				
1-8				

2. Test Specifications

2-1 Timing device	N = rpm	900	1,400	2,200
	mm	2.1~ 2.9	4.0~ 5.2	7.7~ 8.6
2-2 Supply pump	N = rpm	900	1,400	2,200
	kg/cm ²	2.8~ 3.6	3.9~ 4.7	5.9~ 6.7
2-3 Overflow delivery	N = rpm	900		
	cc/10s	36.0~80.0		
2-4 Fuel injection quantities				
Speed control lever position	Pump speed (rpm)	Fuel delivery (cc/1,000st)	Charge air press(mmHg)	Difference in delivery(cc)
Full speed position	600	29.7~30.7		
	900	36.4~38.4	160~180	
	2,200	36.0~41.0	500~520	
	2,700	6.2~13.2	500~520	
	2,800	Below 6	500~520	
Switch OFF	325	0		
Idling position	325	4.0~ 8.0		
	500	Below 3		
Partial load	900	7.0~17.0	160~180	
2-5 Solenoid	Max.cut-in voltage : 8 V Test voltage : 12~14 V			

3. Dimensions

K	3.2~3.4	mm
KF	5.65~5.85	mm
MS	0.6~0.8	mm
BCS	3.7~3.9	mm
Control lever angle		
α	21.0~29.0	deg
A	-	mm
β	36.0~46.0	deg
B	-	mm
γ	10.5~11.5	deg
C	-	mm

Note

After adjustment of full load fuel injection quantity (600rpm), set the boost pressure at 160~180 mmHg or 1~1.5 kg/cm², and at pump speed of 900 rpm adjust the fuel injection quantity using the BCS spring set screw.

INJ. PUMP CALIBRATION DATA

Distributor-type

TEST OIL:
I S O 4113 or
S A E J967d

ENGINE MODEL : LD20T

BOSCH No.9 460 610 024

DKKC No. 104740-2002

Date : 20.Nov.1986 2

Company : NISSAN

No. 16700 W3400

104740-2002

Injection pump No: 104640-2002 (NP-VE4/10F2400RNP83)

Pump rotation : clockwise-viewed from drive side

For Test Condition see
Microfiche No.WP-210(N16)

Pre-stroke : — mm

1. Setting	Pump speed (rpm)	Settings	Charge air press(mmHg)	Difference in delivery(cc)
1-1 Timing device travel	900	2.2~ 2.8 (mm)	160~180	2.5
1-2 Supply pump pressure	900	2.9~ 3.5 (kg/cm ²)	160~180	
1-3 Full load delivery without charge air pressure	600	29.7~30.7 (cc/1,000st)		
Full load delivery with charge air pressure	900	36.9~37.9 (cc/1,000st)	160~180	3.0
1-4 Idle speed regulation	325	4.5~ 7.5 (cc/1,000st)		
1-5 Start	100	40.3~60.3 (cc/1,000st)		
1-6 Full-load speed regulation	2,700	6.7~12.7 (cc/1,000st)	500~520	
1-7				
1-8				

2. Test Specifications

2-1 Timing device	N = rpm	900	1,400	2,200
	mm	2.1~ 2.9	4.0~ 5.2	7.7~ 8.6
2-2 Supply pump	N = rpm	900	1,400	2,200
	kg/cm ²	2.8~ 3.6	3.9~ 4.7	5.9~ 6.7
2-3 Overflow delivery	N = rpm	900		
	cc/10s	36.0~80.0		

2-4 Fuel injection quantities

Speed control lever position	Pump speed (rpm)	Fuel delivery (cc/1,000st)	Charge air press(mmHg)	Difference in delivery(cc)
Full speed position	600	29.7~30.7		
	900	36.4~38.4	160~180	
	2,200	36.9~41.9	500~520	
	2,700	6.2~13.2	500~520	
	2,800	Below 6	500~520	
Switch OFF	325	0		
Idling position	325	4.0~ 8.0		
	500	Below 3		
Partial load	900	7.0~17.0	160~180	
2-5 Solenoid	Max.cut-in voltage : 8 V Test voltage : 12~14 V			

3. Dimensions

K	3.2~3.4	mm
KF	5.65~5.85	mm
MS	0.4~0.6	mm
BCS	3.7~3.9	mm
Control lever angle		
α	21.0~29.0	deg
A	—	mm
β	36.0~46.0	deg
B	—	mm
γ	10.5~11.5	deg
C	—	mm

○ Note

After adjustment of full load fuel injection quantity (600rpm), set the boost pressure at 160~180 mmHg or — kg/cm², and at pump speed of 900 rpm adjust the fuel injection quantity using the BCS spring set screw.

INJ. PUMP CALIBRATION DATA

Distributor-type

TEST OIL:
I S O 4113 cr
S A E J967d

ENGINE MODEL : LD20T

Injection pump No: 104640-2020 [NP-VE4/10F2400RNP158]

Pump rotation : clockwise-viewed from drive side

Pre-stroke : - mm

BOSCH No.9 460 610 025

DKKC No. 104740-2020

Date : 20.Nov.1986 [2]

Company : NISSAN

No. 16700 R8400

For Test Condition see
Microfiche No.WP-210(N16)

○ Note

After adjustment of full load fuel injection quantity (600rpm) , set the boost pressure at 160~180 mmHg or - kg/cm², and at pump speed of 900 rpm adjust the fuel injection quantity using the BCS spring set screw.

1. Setting	Pump speed (rpm)	Settings	Charge air press(mmHg)	Difference in delivery(cc)
1-1 Timing device travel	900	2.2~ 2.8 (mm)	160~180	
1-2 Supply pump pressure	900	2.9~ 3.5 (kg/cm ²)	160~180	
1-3 Full load delivery without charge air pressure	600	29.7~30.7 (cc/1,000st)		2.5
Full load delivery with charge air pressure	900	36.9~37.9 (cc/1,000st)	160~180	
1-4 Idle speed regulation	325	4.5~ 7.5 (cc/1,000st)		3.0
1-5 Start	100	40.3~60.3 (cc/1,000st)		
1-6 Full-load speed regulation	2,700	6.7~12.7 (cc/1,000st)	500~520	
1-7				
1-8				

2. Test Specifications

2-1 Timing device	N = rpm mm	900 2.1~ 2.9	1,400 4.0~ 5.2	2,200 7.7~ 8.6
2-2 Supply pump	N = rpm kg/cm ²	900 2.8~ 3.6	1,400 3.9~ 4.7	2,200 5.9~ 6.7
2-3 Overflow delivery	N = rpm cc/10s	900 36.0~80.0		
2-4 Fuel injection quantities				
Speed control lever position	Pump speed (rpm)	Fuel delivery (cc/1,000st)	Charge air press(mmHg)	Difference in delivery(cc)
Full speed position	600	29.7~30.7		
	900	36.4~38.4	160~180	
	2,200	36.9~41.9	500~520	
	2,700	6.2~13.2	500~520	
	2,800	Below 6	500~520	
Switch OFF	325	0		
Idling position	325	4.0~ 8.0		
	500	Below 3		
Partial load	900	7.0~17.0	160~180	
2-5 Solenoid	Max.cut-in voltage : 8 V Test voltage : 12~14 V			

3. Dimensions

K	3.2~3.4 mm
KF	5.65~5.85 mm
MS	0.4~0.6 mm
BCS	3.7~3.9 mm
Control lever angle	
α	21.0~29.0 deg
A	- mm
β	36.0~46.0 deg
B	- mm
γ	10.5~11.5 deg
C	- mm

INJ. PUMP CALIBRATION DATA

Distributor-type

TEST OIL:
ISO 4113 or
SAE J967d

ENGINE MODEL : LD20T

BOSCH No.9 460 610 026

DKKC No. 104740-2021

Date : 20.Nov.1986 2

Company : NISSAN

No. 16700 R8400

104740-2021

Injection pump No: 104640-2021 [NP-VE4/10F2400RNP158]

Pump rotation : clockwise-viewed from drive side

For Test Condition see
Microfiche No.WP-210(N16)

Pre-stroke : - mm

○ Note

After adjustment of full load fuel injection quantity (600rpm) , set the boost pressure at 160~180 mmHg or - kg/cm², and at pump speed of 900 rpm adjust the fuel injection quantity using the BCS spring set screw.

1. Setting	Pump speed (rpm)	Settings	Charge air press(mmHg)	Difference in delivery(cc)
1-1 Timing device travel	900	2.2~ 2.8 (mm)	160~180	
1-2 Supply pump pressure	900	2.9~ 3.5 (kg/cm ²)	160~180	
1-3 Full load delivery without charge air pressure	600	29.7~30.7 (cc/1,000st)		2.5
Full load delivery with charge air pressure	900	36.9~37.9 (cc/1,000st)	160~180	
1-4 Idle speed regulation	325	4.5~ 7.5 (cc/1,000st)		3.0
1-5 Start	100	40.3~60.3 (cc/1,000st)		
1-6 Full-load speed regulation	2,700	6.7~12.7 (cc/1,000st)	500~520	
1-7				
1-8				

2. Test Specifications

2-1 Timing device	N = rpm	900	1,400	2,200
	mm	2.1~ 2.9	4.0~ 5.2	7.7~ 8.6
2-2 Supply pump	N = rpm	900	1,400	2,200
	kg/cm ²	2.8~ 3.6	3.9~ 4.7	5.9~ 6.7
2-3 Overflow delivery	N = rpm	900		
	cc/10s	36.0~80.0		

2-4 Fuel injection quantities

Speed control lever position	Pump speed (rpm)	Fuel delivery (cc/1,000st)	Charge air press(mmHg)	Difference in delivery(cc)
Full speed position	600	29.7~30.7		
	900	36.4~38.4	160~180	
	2,200	35.5~40.5	500~520	
	2,700	6.2~13.2	500~520	
	2,800	Below 6	500~520	
Switch OFF	325	0		
Idling position	325	4.0~ 8.0		
	500	Below 3		
Partial load	900	7.0~17.0	160~180	
2-5 Solenoid	Max.cut-in voltage : 8 V Test voltage : 12~14 V			

3. Dimensions

K	3.2~3.4	mm
KF	5.65~5.85	mm
MS	0.4~0.6	mm
BCS	3.4~3.6	mm
Control lever angle		
α	21.0~29.0	deg
A	-	mm
β	36.0~46.0	deg
B	-	mm
γ	10.5~11.5	deg
C	-	mm

INJ. PUMP CALIBRATION DATA

Distributor-type

TEST OIL:
I S O 4113 or
S A E J967d

ENGINE MODEL : LD20T

BOSCH No.9 460 610 027

DKKC No. 104740-2022

Date : 20.Nov.1986 2

Company : NISSAN

No. 16700 R8400

104740-2022

Injection pump No: 104640-2022 (NP-VE4/10F2400RNP158)

Pump rotation : clockwise-viewed from drive side

For Test Condition see
Microfiche No.WP-210(N16)

Pre-stroke : - mm

1. Setting	Pump speed (rpm)	Settings	Charge air press(mmHg)	Difference in delivery(cc)
1-1 Timing device travel	900	2.2~ 2.8 (mm)	160~180	
1-2 Supply pump pressure	900	2.9~ 3.5 (kg/cm ²)	160~180	
1-3 Full load delivery without charge air pressure	600	29.7~30.7 (cc/1,000st)		2.5
Full load delivery with charge air pressure	900	36.9~37.9 (cc/1,000st)	160~180	
1-4 Idle speed regulation	325	4.5~ 7.5 (cc/1,000st)		3.0
1-5 Start	100	40.3~60.3 (cc/1,000st)		
1-6 Full-load speed regulation	2,700	6.7~12.7 (cc/1,000st)	500~520	
1-7				
1-8				

2. Test Specifications

2-1 Timing device	N = rpm mm	900 2.1~ 2.9	1,400 4.0~ 5.2	2,200 7.7~ 8.6
2-2 Supply pump	N = rpm kg/cm ²	900 2.8~ 3.6	1,400 3.9~ 4.7	2,200 5.9~ 6.7
2-3 Overflow delivery	N = rpm cc/10s	900 36.0~80.0		
2-4 Fuel injection quantities				
Speed control lever position	Pump speed (rpm)	Fuel delivery (cc/1,000st)	Charge air press(mmHg)	Difference in delivery(cc)
Full speed position	600	29.7~30.7		
	900	36.4~38.4	160~180	
	2,200	35.5~40.5	500~520	
	2,700	6.2~13.2	500~520	
	2,800	Below 6	500~520	
Switch OFF	325	0		
Idling position	325	4.0~ 8.0		
	500	Below 3		
Partial load	900	7.0~17.0	160~180	
2-5 Solenoid	Max.cut-in voltage : 8 V Test voltage : 12~14 V			

3. Dimensions

K	3.2~3.4	mm
KF	5.65~5.85	mm
MS	0.4~0.6	mm
BCS	3.4~3.6	mm

Control lever angle

α	21.0~29.0	deg
A	-	mm
β	36.0~46.0	deg
B	-	mm
γ	10.5~11.5	deg
C	-	mm

○ Note

After adjustment of full load fuel injection quantity (600rpm) , set the boost pressure at 160~180 mmHg or - kg/cm². and at pump speed of 900 rpm adjust the fuel injection quantity using the BCS spring set screw.

INJ. PUMP CALIBRATION DATA

Distributor-type

ENGINE MODEL : LD20T

BOSCH No.9 460 610 028

DKKC No. 104740-2030

Date : 20.Nov.1986 2

Company : NISSAN

No. 16700 02C00

104740-2030

TEST OIL:
ISO 4113 or
SAF J967d

Injection pump No: 104640-2030 [NP-VE4/10F2400RNP158]

Pump rotation : clockwise-viewed from drive side

For Test Condition see
Microfiche No.WP-210(N16)

Pre-stroke : — mm

○ Note

After adjustment of full load fuel injection quantity (600rpm), set the boost pressure at 160~180 mmHg or — kg/cm², and at pump speed of 900 rpm adjust the fuel injection quantity using the BCS spring set screw.

1. Setting	Pump speed (rpm)	Settings	Charge air press(mmHg)	Difference in delivery(cc)
1-1 Timing device travel	900	2.2~ 2.8 (mm)	160~180	
1-2 Supply pump pressure	900	2.9~ 3.5 (kg/cm ²)	160~180	
1-3 Full load delivery without charge air pressure	600	29.7~30.7 (cc/1,000st)		2.5
Full load delivery with charge air pressure	900	36.9~37.9 (cc/1,000st)	160~180	
1-4 Idle speed regulation	325	4.5~ 7.5 (cc/1,000st)		3.0
1-5 Start	100	40.3~60.3 (cc/1,000st)		
1-6 Full-load speed regulation	2,700	6.7~12.7 (cc/1,000st)	500~520	
1-7				
1-8				

2. Test Specifications

2-1 Timing device	N = rpm	900	1,400	2,200
	mm	2.1~ 2.9	4.0~ 5.2	7.7~ 8.6
2-2 Supply pump	N = rpm	900	1,400	2,200
	kg/cm ²	2.8~ 3.6	3.9~ 4.7	5.9~ 6.7
2-3 Overflow delivery	N = rpm	900		
	cc/10s	36.0~80.0		

2-4 Fuel injection quantities

Speed control lever position	Pump speed (rpm)	Fuel delivery (cc/1,000st)	Charge air press(mmHg)	Difference in delivery(cc)
Full speed position	600	29.7~30.7		
	900	36.4~38.4	160~180	
	2,200	35.5~40.5	500~520	
	2,700	6.2~13.2	500~520	
	2,800	Below 6	500~520	
Switch OFF	325	0		
Idling position	325	4.0~ 8.0		
	500	Below 3		
Partial load	900	7.0~17.0	160~180	
2-5 Solenoid	Max.cut-in voltage : 8 V Test voltage : 12~14 V			

3. Dimensions

K	3.2~3.4	mm
KF	5.65~5.85	mm
MS	0.4~0.6	mm
BCS	3.4~3.6	mm
Control lever angle		
α	21.0~29.0	deg
A	—	mm
β	36.0~46.0	deg
B	—	mm
γ	10.5~11.5	deg
C	—	mm

INJ. PUMP CALIBRATION DATA

Distributor-type

ENGINE MODEL : LD20T

BOSCH No.9 460 610 029

DKKC No. 104740-2031

Date : 20.Nov.1986 2

Company : NISSAN

No. 16700 02C00

104740-2031

TEST OIL:
I S O 4113 or
S A E J967d

Injection pump No: 104640-2031 (NP-VE4/10F2400RNP158)

Pump rotation : clockwise-viewed from drive side

For Test Condition see
Microfiche No.WP-210(N16)

Pre-stroke : - mm

1. Setting	Pump speed (rpm)	Settings	Charge air press(mmHg)	Difference in delivery(cc)
1-1 Timing device travel	900	2.2~ 2.8 (mm)	160~180	2.5
1-2 Supply pump pressure	900	2.9~ 3.5 (kg/cm ²)	160~180	
1-3 Full load delivery without charge air pressure	600	29.7~30.7 (cc/1,000st)		
Full load delivery with charge air pressure	900	36.9~37.9 (cc/1,000st)	160~180	3.0
1-4 Idle speed regulation	325	4.5~ 7.5 (cc/1,000st)		
1-5 Start	100	40.3~60.3 (cc/1,000st)		
1-6 Full-load speed regulation	2,700	6.7~12.7 (cc/1,000st)	500~520	
1-7				
1-8				

2. Test Specifications

2-1 Timing device	N = rpm	900	1,400	2,200	
	mm	2.1~ 2.9	4.0~ 5.2	7.7~ 8.6	
2-2 Supply pump	N = rpm	900	1,400	2,200	
	kg/cm ²	2.8~ 3.6	3.9~ 4.7	5.9~ 6.7	
2-3 Overflow delivery	N = rpm	900			
	cc/10s	36.0~80.0			
2-4 Fuel injection quantities					
Speed control lever position	Pump speed (rpm)	Fuel delivery (cc/1,000st)	Charge air press(mmHg)	Difference in delivery(cc)	
Full speed position	600	29.7~30.7			
	900	36.4~38.4	160~180		
	2,200	35.5~40.5	500~520		
	2,700	6.2~13.2	500~520		
	2,800	Below 6	500~520		
Switch OFF	325	0			
Idling position	325	4.0~ 8.0			
	500	Below 3			
Partial load	900	7.0~17.0	160~180		
2-5 Solenoid	Max.cut-in voltage : 8 V Test voltage : 12~14 V				

3. Dimensions

K	3.2~3.4	mm
KF	5.65~5.85	mm
MS	0.4~0.6	mm
BCS	3.4~3.6	mm

Control lever angle

α	21.0~29.0	deg
A	—	mm
β	36.0~46.0	deg
B	—	mm
γ	10.5~11.5	deg
C	—	mm

○ Note

After adjustment of full load fuel injection quantity (600rpm), set the boost pressure at 160~180 mmHg or — kg/cm², and at pump speed of 900 rpm adjust the fuel injection quantity using the BCS spring set screw.

INJ. PUMP CALIBRATION DATA

Distributor-type

ENGINE MODEL : 4D55T

TEST OIL:
I S O 4113 or
S A E J967d

Injection pump No: 104640-3010 (NP-VE4/10F2100RNP30)

BOSCH No.9 460 610 001
DKKC No. 104740-3010
Date : 20.Nov.1986
Company : MITSUBISHI
No. MD050052

Pump rotation : clockwise-viewed from drive side

For Test Condition see
Microfiche No.WP-210(N16)

Pre-stroke : - mm

1. Setting	Pump speed (rpm)	Settings	Charge air press(mmHg)	Difference in delivery(cc)
1-1 Timing device travel	1,250	5.5~5.9 (mm)	0	
1-2 Supply pump pressure	1,250	4.5~5.1 (kg/cm ²)	0	
1-3 Full load delivery without charge air pressure	600	35.3~36.3 (cc/1,000st)	0	2.0
Full load delivery with charge air pressure	1,250	46.5~47.5 (cc/1,000st)	360~380	
1-4 Idle speed regulation	375	6.4~10.4 (cc/1,000st)	0	2.5
1-5 Start	100	66.0~81.0 (cc/1,000st)	0	
1-6 Full-load speed regulation	2,400	5.4~11.4 (cc/1,000st)	615~635	
1-7				
1-8				

2. Test Specifications	Solenoid Timer	ON			OFF	
2-1 Timing device	N = rpm mm	600 1.1~2.3	1,250 5.5~5.9	1,950 9.2~10.4	1,250 2.0~3.2	1,950 5.9~7.1
2-2 Supply pump	N = rpm kg/cm ²	600 2.9~3.5	1,250 4.5~5.1	1,950 6.2~6.8		
2-3 Overflow delivery	N = rpm cc/10s	1,250 95~148				

2-4 Fuel injection quantities				
Speed control lever position	Pump speed (rpm)	Fuel delivery (cc/1,000st)	Charge air press(mmHg)	Difference in delivery(cc)
Full speed position	600	34.8~36.8	0	
	1,250	46.0~48.0	360~380	
	2,100	44.2~49.2	615~635	
	2,400	4.4~12.4	615~635	
	2,600	Below 5.0	615~635	
Switch OFF	375	0		
Idling position	375	6.4~10.4		
	600	Below 3		
Partial load	600	14.5~26.5		
2-5 Solenoid	Max.cut-in voltage : 8 V Test voltage : 12~14 V			

3. Dimensions		
K	3.2~3.4	mm
KF	5.7~5.9	mm
MS	0.8~1.0	mm
BCS	4.4~4.6	mm
Control lever angle		
α	55.0~63.0	deg
A	-	mm
β	41.0~51.0	deg
B	-	mm
Y	11.5~12.5	deg
C	-	mm

○ Note

■ RUN the pump at 1250rpm, and switch the solenoid timer ON-OFF five or six times to check that it operates properly.

○ Note

After adjustment of full load fuel injection quantity (600rpm), set the boost pressure at 360~380 mmHg or - kg/cm², and at pump speed of 1250 rpm adjust the fuel injection quantity using the BCS spring set screw.

○ Note

■ Check that the injection quantity is within the specified range even when the boost pressure exceeds 700 mmHg.

○ Note

■ If there is no designation in the specifications Solenoid Timer ON-OFF position, then the position should be regarded ON.

■ Accelerator Switch Installation Adjustment

1. Insert a block gauge (thickness gauge) of 5.2 mm thickness between the fall speed stopper bolt and control lever.
2. With the control lever in the position described in step 1, adjust the installation position of the accelerator switch, and set it so that it can change from OFF to ON.

■ W-CSD Adjustment

1) Timer stroke adjustment

1. Calculate the timer stroke from Fig. 2 according to the atmospheric temperature at the time of adjustment.
2. Adjust using timer stroke adjusting screw so that the timer stroke is as calculated in Step 1.

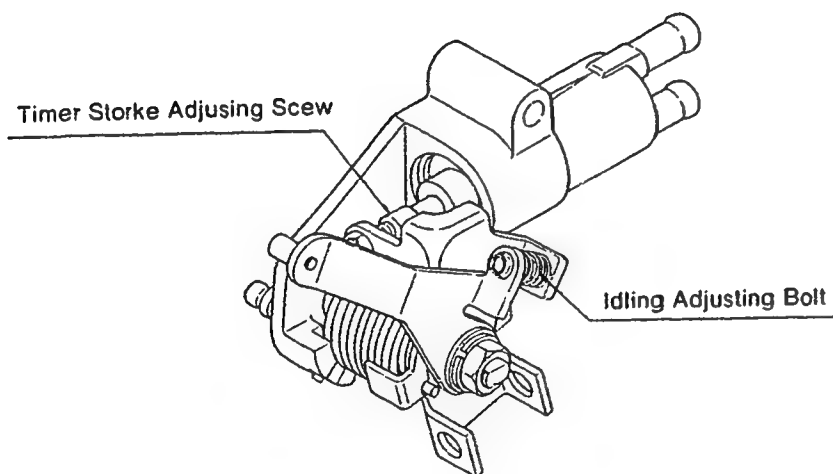

Fig. 1

2) CSD lever adjustment

1. Calculate the block gauge dimension $l \pm 0.05\text{mm}$ from Fig. 2 according to the atmospheric temperature at the time of adjustment.
2. Insert the block gauge (thickness gauge) between the control lever and the idling stopper bolt.
3. Using the idling adjusting bolt, adjust so that the CSD lever roller and control lever are in contact.

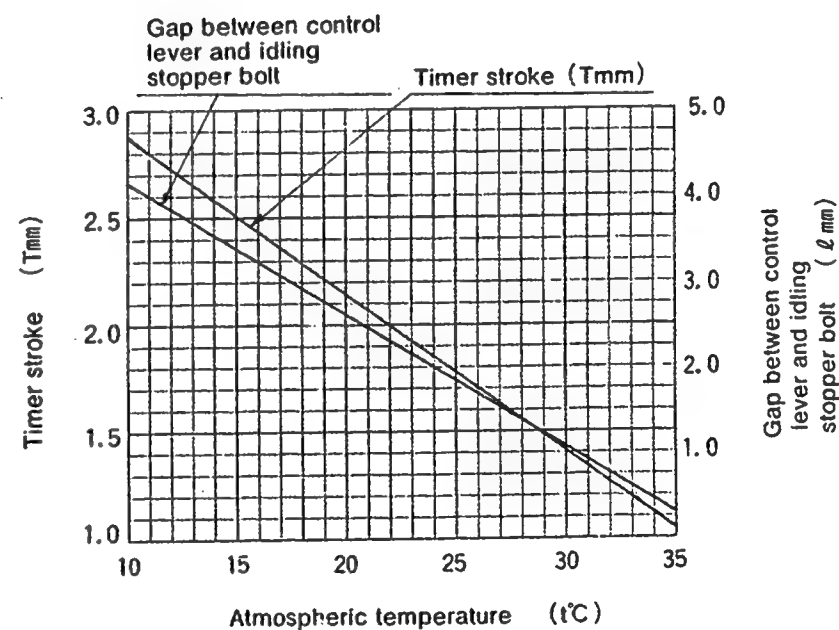

Fig. 2

INJ. PUMP CALIBRATION DATA

Distributor-type

ENGINE MODEL : 4D55T

BOSCH No.9 460 610 002

DKKC No. 104740-3011

Date : 20.Nov.1986 Q

Company : MITSUBISHI

No. MD050052

TEST OIL:
I S O 4113 or
S A E J967d

Injection pump No: 104640-3011 [NP-VE4/10F2100RNP30]

Pump rotation : clockwise-viewed from drive side

Pre-stroke : — mm

For Test Condition see
Microfiche No.WP-210(N16)

1. Setting	Pump speed (rpm)	Settings	Charge air press(mmHg)	Difference in delivery(cc)
1-1 Timing device travel	850	3.1~ 3.5 (mm)	0	
1-2 Supply pump pressure	1,250	4.5~ 5.1 (kg/cm ²)	0	
1-3 Full load delivery without charge air pressure	600	32.7~33.7 (cc/1,000st)	0	2.5
Full load delivery with charge air pressure	750	36.2~37.2 (cc/1,000st)	100~120	
1-4 Idle speed regulation	375	6.4~10.4 (cc/1,000st)	0	2.5
1-5 Start	100	66.0~86.0 (cc/1,000st)	0	
1-6 Full-load speed regulation	2,650	19.1~25.2 (cc/1,000st)	615~635	6.5
1-7				
1-8				

2. Test Specifications		Solenoid Timer	ON		OFF
2-1 Timing device	N = rpm	850	1,750	2,100	1,750
	mm	3.1~ 3.5	8.1~ 9.3	9.9~10.7	4.8~ 6.0
2-2 Supply pump	N = rpm	600	1,250	2,100	
	kg/cm ²	2.9~ 3.5	4.5~ 5.1	6.5~ 7.1	
2-3 Overflow delivery	N = rpm	1,250			
	cc/10s	95~148			
2-4 Fuel injection quantities					
Speed control lever position	Pump speed (rpm)	Fuel delivery (cc/1,000st)	Charge air press(mmHg)	Difference in delivery(cc)	
Full speed position	600	32.2~34.2	0		
	750	35.7~37.7	100~120		
	1,250	49.3~53.3	468~488		
	2,100	42.8~47.8	615~635		
	2,650	18.1~26.1	615~635		
	3,050	Below 10	615~635		
Switch OFF	375	0			
Idling position	600	Below 3			
	375	6.4~10.4			
Partial load	600	14.5~26.5			
2-5 Solenoid	Max.cut-in voltage : 8 V				
	Test voltage : 12~14 V				

3. Dimensions

K	3.2~3.4	mm
KF	5.7~5.9	mm
MS	0.8~1.0	mm
BCS	4.4~4.6	mm

Control lever angle

α	55.0~63.0	deg
A	—	mm
β	41.0~51.0	deg
B	—	mm
γ	11.5~12.5	deg
C	—	mm

○ Note

■ RUN the pump at 1750rpm, and switch the solenoid timer ON-OFF five or six times to check that it operates properly.

○ Note

■ After adjustment of full load fuel injection quantity (600 rpm) , set the boost pressure at 100~120 mmHg or — kg/cm², and at pump speed of 750 rpm adjust the fuel injection quantity using the BCS spring set screw.

○ Note

■ Check that the injection quantity is within the specified range even when the boost pressure exceeds 700 mmHg.

○ Note

■ If there is no designation in the specifications Solenoid Timer ON-OFF position, then the position should be regarded ON.

■ Accelerator Switch Installation Adjustment

1. Insert a block gauge (thickness gauge) of 5.2 mm thickness between the fail speed stopper bolt and control lever.
2. With the control lever in the position described in step 1, adjust the installation position of the accelerator switch, and set it so that it can change from OFF to ON.

■ W-CSD Adjustment

1) Timer stroke adjustment

1. Calculate the timer stroke from Fig. 2 according to the atmospheric temperature at the time of adjustment.
2. Adjust using timer stroke adjusting screw so that the timer stroke is as calculated in Step 1.

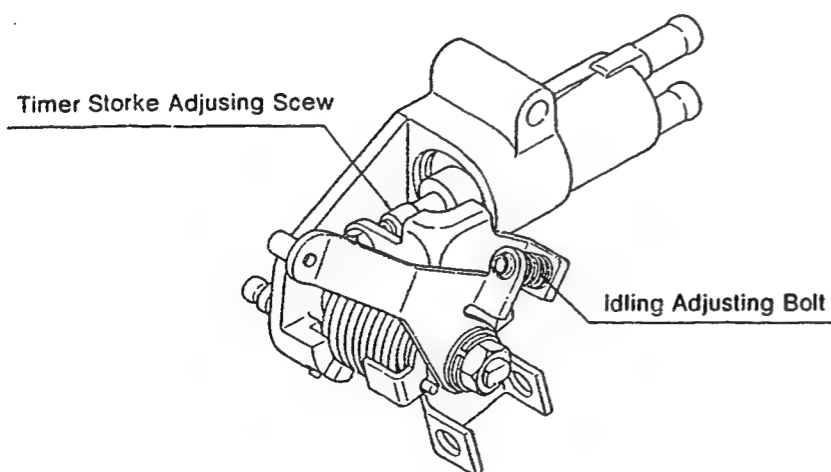

Fig. 1

2) CSD lever adjustment

1. Calculate the block gauge dimension $\ell \pm 0.05\text{mm}$ from Fig. 2 according to the atmospheric temperature at the time of adjustment.
2. Insert the block gauge (thickness gauge) between the control lever and the idling stopper bolt.
3. Using the idling adjusting bolt, adjust so that the CSD lever roller and control lever are in contact.

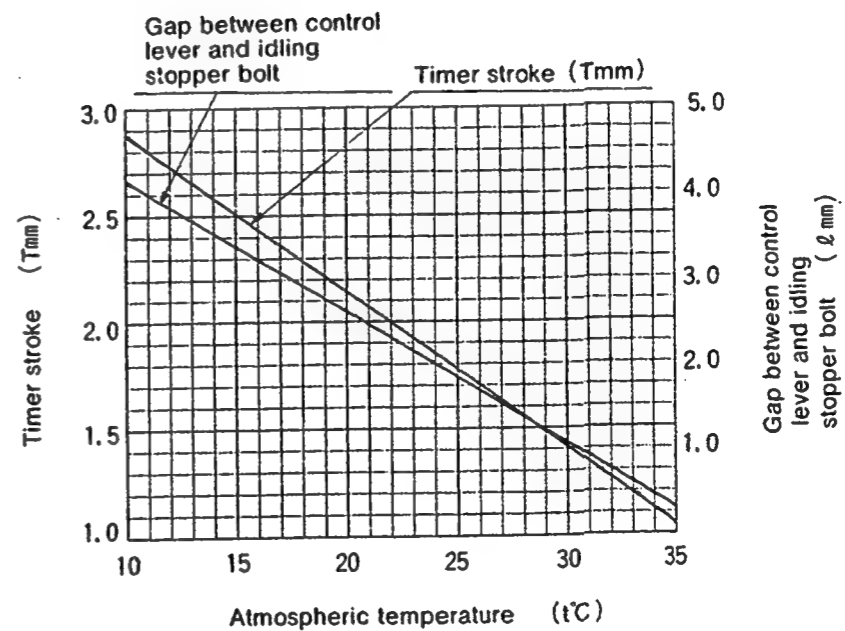

Fig. 2

INJ. PUMP CALIBRATION DATA

Distributor-type

TEST OIL:
I S O 4113 or
S A E J967d

ENGINE MODEL : 4D55T

Injection pump No: 104640-3030 (NP-VE4/10F2100RNP76)

Pump rotation : clockwise-viewed from drive side

Pre-stroke : - mm

1/4
BOSCH No.9 460 610 030

DKKC No. 104740-3030

Date : 20.Nov.1986 0

Company : MITSUBISHI

No. MD050631

For Test Condition see
Microfiche No.WP-210(N16)

104740-3030 2/4

1. Setting	Pump speed (rpm)	Settings	Charge air press(mmHg)	Difference in delivery(cc)
1-1 Timing device travel	1,250	5.5~5.9 (mm)	0	
1-2 Supply pump pressure	1,250	4.5~5.1 (kg/cm ²)	0	
1-3 Full load delivery without charge air pressure	600	35.3~36.3 (cc/1,000st)	0	2.0
Full load delivery with charge air pressure	1,250	46.5~47.5 (cc/1,000st)	360~380	
1-4 Idle speed regulation	375	6.4~10.4 (cc/1,000st)	0	2.5
1-5 Start	100	66.0~81.0 (cc/1,000st)	0	
1-6 Full-load speed regulation	2,400	5.4~11.4 (cc/1,000st)	615~635	
1-7				
1-8				

2. Test Specifications		Solenoid Timer	ON			OFF	
2-1	Timing device	N = rpm mm	600 1.1~2.3	1,250 5.5~5.9	1,950 9.2~10.4	1,250 2.0~3.2	1,950 5.9~7.1
2-2	Supply pump	N = rpm kg/cm ²	600 2.9~3.5	1,250 4.5~5.1	1,950 6.2~6.8		
2-3	Overflow delivery	N = rpm cc/10s	1,250 95~148				
2-4 Fuel injection quantities							
Speed control lever position	Pump speed (rpm)	Fuel delivery (cc/1,000st)	Charge air press(mmHg)	Difference in delivery(cc)			
Full speed position	600	34.8~36.8	0				
	1,250	46.0~48.0	360~380				
	2,100	44.2~49.2	615~635				
	2,400	4.4~12.4	615~635				
	2,600	Below 5.0	615~635				
Switch OFF	375	0					
Idling position	375	6.4~10.4					
	600	Below 3					
Partial load	600	14.5~26.5					
2-5 Solenoid	Max.cut-in voltage : 8 V Test voltage : 12~14 V						

3. Dimensions

K	3.2~3.4	mm
KF	5.7~5.9	mm
MS	0.8~1.0	mm
BCS	4.4~4.6	mm

Control lever angle

α	55.0~63.0	deg
A	-	mm
β	41.0~51.0	deg
B	-	mm
γ	11.5~12.5	deg
C	-	mm

○ Note

■ RUN the pump at 1250 rpm, and switch the solenoid timer ON-OFF five or six times to check that it operates properly.

○ Note

After adjustment of full load fuel injection quantity (600rpm), set the boost pressure at 360~380 mmHg or - kg/cm², and at pump speed of 1250 rpm adjust the fuel injection quantity using the BCS spring set screw.

○ Note

■ Check that the injection quantity is within the specified range even when the boost pressure exceeds 700 mmHg.

○ Note

■ If there is no designation in the specifications Solenoid Timer ON-OFF position, then the position should be regarded ON.

■ Accelerator Switch Installation Adjustment

1. Insert a block gauge (thickness gauge) of 5.2 mm thickness between the fall speed stopper bolt and control lever.
2. With the control lever in the position described in step 1, adjust the installation position of the accelerator switch, and set it so that it can change from OFF to ON.

■ W-CSD Adjustment

1) Timer stroke adjustment

1. Calculate the timer stroke from Fig. 2 according to the atmospheric temperature at the time of adjustment.
2. Adjust using timer stroke adjusting screw so that the timer stroke is as calculated in Step 1.

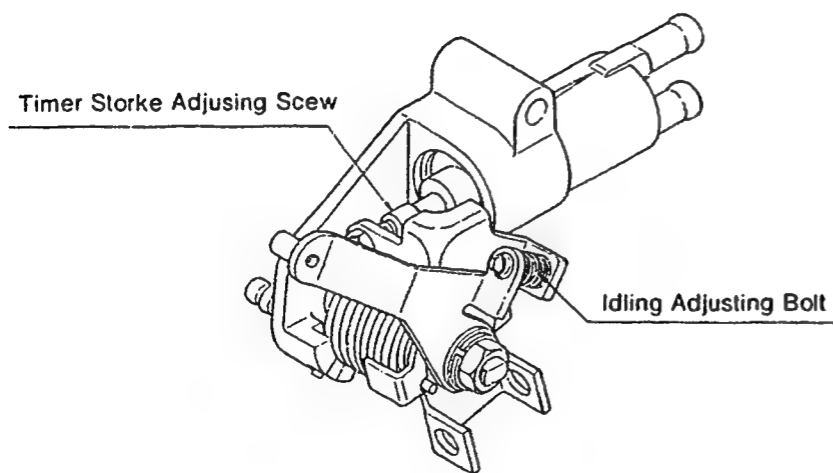

Fig. 1

2) CSD lever adjustment

1. Calculate the block gauge dimension $\ell \pm 0.05\text{mm}$ from Fig. 2 according to the atmospheric temperature at the time of adjustment.
2. Insert the block gauge (thickness gauge) between the control lever and the idling stopper bolt.
3. Using the idling adjusting bolt, adjust so that the CSD lever roller and control lever are in contact.

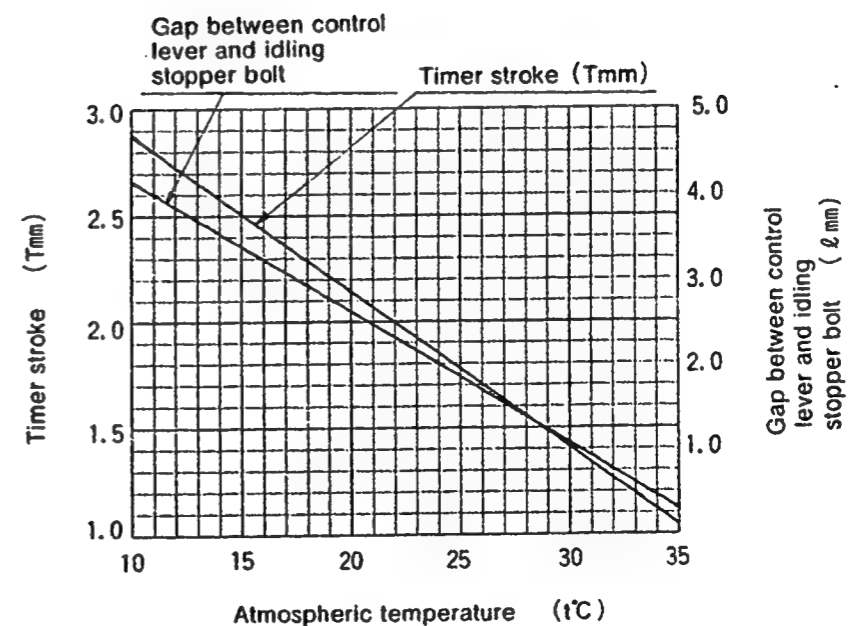

Fig. 2

INJ. PUMP CALIBRATION DATA

Distributor-type

TEST OIL:
I S O 4113 or
S A E J967d

ENGINE MODEL : 4D55T

Injection pump No: 104640-3031 [NP-VE4/10F2100RNP76]

BOSCH No.9 460 610 031
DKKC No. 104740-3031
Date : 20.Nov.1986 0
Company: MITSUBISHI
No. MD050631

Pump rotation : clockwise-viewed from drive side

For Test Condition see
Microfiche No.WP-210(N16)

Pre-stroke : — mm

1. Setting	Pump speed (rpm)	Settings	Charge air press(mmHg)	Difference in delivery(cc)
1-1 Timing device travel	850	3.1~ 3.5 (mm)	0	
1-2 Supply pump pressure	1,250	4.5~ 5.1 (kg/cm ²)	0	
1-3 Full load delivery without charge air pressure	600	32.7~33.7 (cc/1,000st)	0	2.5
Full load delivery with charge air pressure	750	36.2~37.2 (cc/1,000st)	100~120	
1-4 Idle speed regulation	375	6.4~10.4 (cc/1,000st)	0	2.5
1-5 Start	100	66.0~86.0 (cc/1,000st)	0	
1-6 Full-load speed regulation	2,650	19.1~25.2 (cc/1,000st)	615~635	6.5
1-7				
1-8				

2. Test Specifications		Solenoid Timer	ON		OFF
2-1 Timing device	N = rpm mm	850	1,750	2,100	1,750
		3.1~ 3.5	8.1~ 9.3	9.9~10.7	4.8~ 6.0
2-2 Supply pump	N = rpm kg/cm ²	600	1,250	2,100	2,100
		2.9~ 3.5	4.5~ 5.1	6.5~ 7.1	
2-3 Overflow delivery	N = rpm cc/10s	1,250			
		95~148			
2-4 Fuel injection quantities					
Speed control lever position	Pump speed (rpm)	Fuel delivery (cc/1,000st)	Charge air press(mmHg)	Difference in delivery(cc)	
Full speed position	600	32.2~34.2	0		
	750	35.7~37.7	100~120		
	1,250	49.3~53.3	468~488		
	2,100	42.8~47.8	615~635		
	2,650	18.1~26.1	615~635		
	3,050	Below 10	615~635		
Switch OFF	375	0			
Idling position	600	Below 3			
	375	6.4~10.4			
Partial load	600	14.5~26.5			
2-5 Solenoid	Max.cut-in voltage : 8 V Test voltage : 12~14 V				

3. Dimensions

K	3.2~3.4	mm
KF	5.7~5.9	mm
MS	0.8~1.0	mm
BCS	4.4~4.6	mm

Control lever angle

α	55.0~63.0	deg
A	—	mm
β	41.0~51.0	deg
B	—	mm
γ	11.5~12.5	deg
C	—	mm

○ Note

■ RUN the pump at 1750rpm, and switch the solenoid timer ON-OFF five or six times to check that it operates properly.

○ Note

■ After adjustment of full load fuel injection quantity (600 rpm) , set the boost pressure at 100~120 mmHg or — kg/cm², and at pump speed of 750 rpm adjust the fuel injection quantity using the BCS spring set screw.

○ Note

■ Check that the injection quantity is within the specified range even when the boost pressure exceeds 700 mmHg.

○ Note

■ If there is no designation in the specifications Solenoid Timer ON-OFF position, then the position should be regarded ON.

■ Accelerator Switch Installation Adjustment

1. Insert a block gauge (thickness gauge) of 5.2 mm thickness between the fall speed stopper bolt and control lever.
2. With the control lever in the position described in step 1, adjust the installation position of the accelerator switch, and set it so that it can change from OFF to ON.

■ W-CSD Adjustment

1) Timer stroke adjustment

1. Calculate the timer stroke from Fig. 2 according to the atmospheric temperature at the time of adjustment.
2. Adjust using timer stroke adjusting screw so that the timer stroke is as calculated in Step 1.

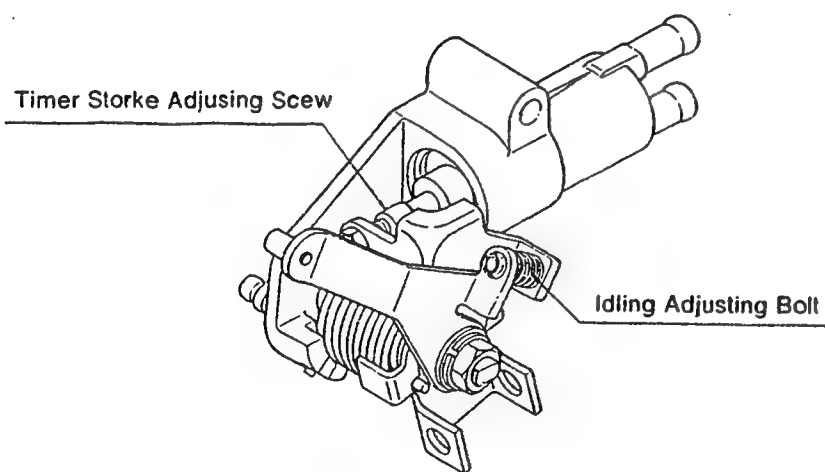

Fig. 1

2) CSD lever adjustment

1. Calculate the block gauge dimension $l \pm 0.05\text{mm}$ from Fig. 2 according to the atmospheric temperature at the time of adjustment.
2. Insert the block gauge (thickness gauge) between the control lever and the idling stopper bolt.
3. Using the idling adjusting bolt, adjust so that the CSD lever roller and control lever are in contact.

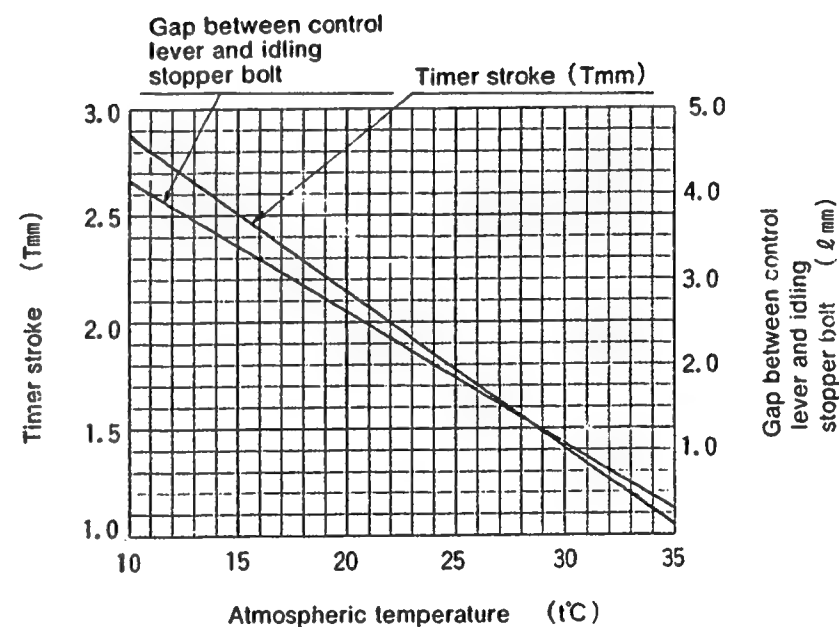

Fig. 2

J - 16

INJ. PUMP CALIBRATION DATA Distributor-type

TEST OIL:
I S O 4113 or
S A E J967d

ENGINE MODEL : 4D55

Injection pump No: 104640-3110 (NP-VE4/10F2100RNP159)

Pump rotation : clockwise-viewed from drive side
Pre-stroke : — mm

BOSCH No.9 460 610 034

DKKC No. 104740-3200

Date : 20.Nov.1986 0

Company : MITSUBISHI

No. MD064562

For Test Condition see
Microfiche No.WP-210(N16)

1. Setting	Pump speed (rpm)	Settings	Charge air press(mmHg)	Difference in delivery(cc)
1-1 Timing device travel	850	1.1~ 5.1 (mm)		
1-2 Supply pump pressure	1,250	4.5~ 5.1 (kg/cm ²)		
1-3 Full load delivery without charge air pressure	750	33.2~34.2 (cc/1,000st)		3.0
Full load delivery with charge air pressure		(cc/1,000st)		
1-4 Idle speed regulation	375	6.9~ 9.9 (cc/1,000st)		2.5
1-5 Start	100	66.0~86.0 (cc/1,000st)		
1-6 Full-load speed regulation	2,350	6.6~12.6 (cc/1,000st)		4.0
1-7				
1-8				

2. Test Specifications

2-1 Timing device	N = rpm mm	850 0.9~ 1.7	1,750 6.1~ 7.3	2,100 7.8~ 8.6
2-2 Supply pump	N = rpm kg/cm ²	600 2.9~ 3.5	1,250 4.5~ 5.1	2,100 6.5~ 7.1
2-3 Overflow delivery	N = rpm cc/10s	1,250 48~92		
2-4 Fuel injection quantities				
Speed control lever position	Pump speed (rpm)	Fuel delivery (cc/1,000st)	Charge air press(mmHg)	Difference in delivery(cc)
Full speed position	750	32.7~34.7		
	1,250	36.7~40.7		
	2,100	32.2~36.2		
	2,350	5.0~14.6		
	2,500	Below 5		
Switch OFF	375	0		
Idling position	600	Below 3		
	375	6.4~10.4		
2-5 Solenoid	Max.cut-in voltage : 8 V Test voltage : 12~14 V			

3. Dimensions

K	3.2~3.4	mm
KF	5.7~5.9	mm
MS	1.3~1.5	mm
BCS	—	mm

Control lever angle

α	55.0~63.0	deg
A	—	mm
β	38.0~48.0	deg
B	—	mm
γ	—	deg
C	—	mm



DIESEL KIKI CO., LTD.
Service Department

3-6-7 SHIBUYA, SHIBUYA-KU, TOKYO 150, JAPAN
Tel. (03) 400-1551 · Fax: (03) 499-4115

INJ. PUMP CALIBRATION DATA

Distributor-type

TEST OIL:
ISO 4113 or
SAE J967d

ENGINE MODEL : 4D55T

BOSCH No. 9 460 610 004
DKKC No. 104740-3540
Date : 20.Nov.1986 0
Company : MITSUBISHI
No. MD077643

104740-3540

Injection pump No: 104640-3270 [NP-VE4/10F2100RNP258]

Pump rotation : clockwise-viewed from drive side

For Test Condition see
Microfiche No.WP-210(N16)

Pre-stroke : - mm

1. Setting	Pump speed (rpm)	Settings	Charge air press(mmHg)	Difference in delivery(cc)
1-1 Timing device travel	1,250	2.7~ 3.1 (mm)		
1-2 Supply pump pressure	1,250	4.5~ 5.1 (kg/cm ²)		
1-3 Full load delivery without charge air pressure	600	37.7~38.7 (cc/1,000st)	0	3.0
Full load delivery with charge air pressure	750	45.8~46.8 (cc/1,000st)	170~190	
1-4 Idle speed regulation	375	6.5~ 9.5 (cc/1,000st)	0	2.0
1-5 Start	100	63.0~83.0 (cc/1,000st)	0	
1-6 Full-load speed regulation	2,650	16.6~22.6 (cc/1,000st)	510~530	5.5
1-7				
1-8				

2. Test Specifications

2-1 Timing device	N = rpm mm	750 0.4~ 1.6	1,250 2.5~ 3.3	1,750 4.2~5.4	2,350 6.2~ 7.0
2-2 Supply pump	N = rpm kg/cm ²	600 2.9~ 3.5	1,250 4.5~ 5.1	2,100 6.5~ 7.1	
2-3 Overflow delivery	N = rpm cc/10s	1,250 48.0~92.0			

2-4 Fuel injection quantities

Speed control lever position	Pump speed (rpm)	Fuel delivery (cc/1,000st)	Charge air press(mmHg)	Difference in delivery(cc)
Full speed position	600	37.2~39.2	0	
	750	45.3~47.3	170~190	
	1,250	54.8~59.3	510~530	
	2,100	49.3~54.3	510~530	
	2,650	14.6~24.6	510~530	
	3,050	Below 5	510~530	
Switch OFF	375	0	0	
Idling position	600	Below 3	0	
	375	6.0~10.0	0	

3. Dimensions

K	3.2~3.4 mm
KF	5.7~5.9 mm
MS	1.3~1.5 mm
BCS	4.3~4.5 mm

Control lever angle

α	55.0~63.0 deg
A	10.5~16.0 mm
β	41.0~51.0 deg
B	12.5~16.5 mm
γ	- deg
C	- mm

○ Note

■ After adjustment of full load fuel injection quantity (600 rpm), set the boost pressure at 180 mmHg or 0.25 kg/cm², and at pump speed of 750 rpm adjust the fuel injection quantity using the BCS spring set screw.

○ Note

■ Check that the injection quantity is within the specified range even when the boost pressure exceeds 700 mmHg.

INJ. PUMP CALIBRATION DATA

Distributor-type

TEST OIL:
ISO 4113 or
SAE J967d

ENGINE MODEL : 4D55T

BOSCH No.9 460 610 044

DKKC No. 104740-3551

Date : 20.Nov.1986 0

Company : MITSUBISHI

No. MD078302

104740-3551

Injection pump No: 104640-3281 (NP-VE4/10F2100RNP264)

Pump rotation : clockwise-viewed from drive side

For Test Condition see
Microfiche No.WP-210(N16)

Pre-stroke : — mm

1. Setting	Pump speed (rpm)	Settings	Charge air press(mmHg)	Difference in delivery(cc)
1-1 Timing device travel	1,250	3.1~ 3.5 (mm)	0	
1-2 Supply pump pressure	1,250	4.5~ 5.1 (kg/cm ²)	0	
1-3 Full load delivery without charge air pressure	600	35.7~36.7 (cc/1,000st)	0	3.0
Full load delivery with charge air pressure	750	42.8~43.8 (cc/1,000st)	180~200	
1-4 Idle speed regulation	375	6.5~ 9.5 (cc/1,000st)	0	2.0
1-5 Start	100	63.0~83.0 (cc/1,000st)	0	
1-6 Full-load speed regulation	2,350	17.1~23.1 (cc/1,000st)	520~540	6.0
1-7				
1-8				

2. Test Specifications

2-1 Timing device	N = rpm mm	750 0.5~ 1.7	1,250 2.9~ 3.7	1,750 4.9~ 6.1	2,100 6.6~ 7.4
2-2 Supply pump	N = rpm kg/cm ²	600 2.9~ 3.5	1,250 4.5~ 5.1	2,100 6.5~ 7.1	
2-3 Overflow delivery	N = rpm cc/10s	1,250 48.0~ 92.0			
2-4 Fuel injection quantities					
Speed control lever position	Pump speed (rpm)	Fuel delivery (cc/1,000st)	Charge air press(mmHg)	Difference in delivery(cc)	
Full speed position	600	35.2~37.2	0		
	750	42.3~44.3	180~200		
	1,250	53.8~58.8	520~540		
	2,100	48.3~53.3	520~540		
	2,350	15.1~25.1	520~540		
	2,500	Below 5	520~540		
Switch OFF	375	0			
Idling position	600	Below 3			
	375	6~10			
2-5 Solenoid	Max.cut-in voltage : 8 V Test voltage : 12~14 V				

3. Dimensions

K	3.2~3.4	mm
KF	5.7~5.9	mm
MS	1.3~1.5	mm
BCS	4.7~4.9	mm

Control lever angle

α	55.0~63.0	deg
A	10.5~16.0	mm
β	36.0~46.0	deg
B	10.5~14.5	mm
γ	—	deg
C	—	mm

○ Note

- After adjustment of full load fuel injection quantity (600 rpm) , set the boost pressure at 190 mmHg or 0.25 kg/cm², and at pump speed of 750 rpm adjust the fuel injection quantity using the BCS spring set screw.

○ Note

- Check that the injection quantity is within the specified range even when the boost pressure exceeds 700 mmHg.

■ FICD Mounting Position Adjustment

1. Hold the control lever in the idling position.
2. Position the FICD mounting bracket so that the gap between the control lever and the FICD lever is 1±1 mm.

INJ. PUMP CALIBRATION DATA

Distributor-type

TEST OIL:
I S O 4113 or
S A E J967d

ENGINE MODEL : SD23

Injection pump No: 104640-425C [NP-VE4/10F2150RNP146]

Pump rotation : clockwise-viewed from drive side

Pre-stroke : — mm

BOSCH No.9 460 610 050

DKKC No. 104740-4250

Date : 20.Nov.1986 0

Company : NISSAN DIESEL

No. 16700 R8308

For Test Condition see
Microfiche No.WP-210(N16)

1. Setting		Pump speed (rpm)	Settings	Charge air press(mmHg)	Difference in delivery(cc)
1-1	Timing device travel	1,700	4.5~ 4.9 (mm)		3.0
1-2	Supply pump pressure	1,700	5.7~ 6.3 (kg/cm ²)		
1-3	Full load delivery without charge air pressure	1,000	35.6~36.6 (cc/1,000st)		
	Full load delivery with charge air pressure		(cc/1,000st)		
1-4	Idle speed regulation	300	4.3~ 8.3 (cc/1,000st)		2.0
1-5	Start	100	55.0~90.0 (cc/1,000st)		
1-6	Full-load speed regulation	2,300	14.7~20.7 (cc/1,000st)		
1-7					
1-8					

2. Test Specifications

2-1	Timing device	N = rpm mm	1,000 1.4~ 2.6	1,700 4.4~ 5.0	2,150 6.1~ 7.1
2-2	Supply pump	N = rpm kg/cm ²	600 3.0~ 3.6	1,700 5.7~ 6.3	2,150 6.8~ 7.4
2-3	Overflow delivery	N = rpm cc/10s	1,000 8.0~52		

2-4 Fuel injection quantities

Speed control lever position	Pump speed (rpm)	Fuel delivery (cc/1,000st)	Charge air press(mmHg)	Difference in delivery(cc)
Full speed position	1,000	35.1~37.1		
	600	29.3~33.3		
	2,150	30.5~34.7		
	2,300	14.2~21.2		
	2,450	Below 5		
Switch OFF	300	0		
Idling position	300	4.3~8.3		
	350	Below 3		

2-5 Solenoid Max.cut-in voltage : 16 V
Test voltage : 24~26 V

3. Dimensions

K	3.2~3.4 mm
KF	5.7~5.9 mm
MS	1.4~1.6 mm
BCS	— mm

Control lever angle

α	21.0~29.0 deg
A	4.0~9.2 mm
β	41.0~51.0 deg
B	12.1~16.1 mm
γ	— deg
C	— mm

INJ. PUMP CALIBRATION DATA

Distributor-type

TEST OIL:
I S O 4113 or
S A E J967d

ENGINE MODEL : SD25

Injection pump No: 104640-4270 [NP-VE4/10F2100RNP151]

Pump rotation : clockwise-viewed from drive side

Pre-stroke : — mm

BOSCH No.9 460 610 006

DKKC No. 104740-4270

Date : 20.Nov.1986 0

Company : NISSAN DIESEL

No. 16700 T8270

For Test Condition see
Microfiche No.WP-210(N16)

1. Setting		Pump speed (rpm)	Settings	Charge air press(mmHg)	Difference in delivery(cc)
1-1	Timing device travel	1,000	1.5~ 1.9 (mm)		3.0
1-2	Supply pump pressure	1,000	4.0~ 4.6 (kg/cm ²)		
1-3	Full load delivery without charge air pressure	1,000	37.9~38.9 (cc/1,000st)		
	Full load delivery with charge air pressure		(cc/1,000st)		
1-4	Idle speed regulation	300	4.5~ 8.5 (cc/1,000st)		2.0
1-5	Start	100	45.0~80.0 (cc/1,000st)		
1-6	Full-load speed regulation	2,250	11.7~17.7 (cc/1,000st)		
1-7					
1-8					

2. Test Specifications

2-1	Timing device	N = rpm mm	1,000 1.4~ 2.0	1,400 3.2~ 4.4	2,100 6.9~ 7.9
2-2	Supply pump	N = rpm kg/cm ²	600 3.1~ 3.7	1,000 4.0~ 4.6	2,100 6.6~ 7.2
2-3	Overflow delivery	N = rpm cc/10s	1,000 8.0~52		

2-4 Fuel injection quantities

Speed control lever position	Pump speed (rpm)	Fuel delivery (cc/1,000st)	Charge air press(mmHg)	Difference in delivery(cc)
Full speed position	1,000	37.4~39.4		
	600	31.2~35.2		
	2,100	32.9~37.1		
	2,250	11.2~18.2		
	2,350	Below 5		
Switch OFF	300	0		
Idling position	300	4.5~8.5		
	350	Below 3		

2-5 Solenoid Max.cut-in voltage : 8 V
Test voltage : 12~14 V

3. Dimensions

K	3.2~3.4 mm
KF	5.7~5.9 mm
MS	1.1~1.3 mm
BCS	— mm

Control lever angle

α	21.0~29.0 deg
A	4.0~9.2 mm
β	37.0~47.0 deg
B	10.7~14.8 mm
γ	— deg
C	— mm

INJ. PUMP CALIBRATION DATA Distributor-type

TEST OIL:
I S O 4113 or
S A E J967d

ENGINE MODEL : SD23

Injection pump No: 104640-4240 (NP-VE4/10F2150RNP145)

Pump rotation : clockwise-viewed from drive side

Pre-stroke : - mm

BOSCH No. 9 460 610 008

DKKC No. 104740-4380

Date : 20. Nov. 1986

Company : NISSAN DIESEL

No. 16700 09W02

For Test Condition see
Microfiche No. WP-210(N16)

1. Setting	Pump speed (rpm)	Settings	Charge air press(mmHg)	Difference in delivery(cc)
1-1 Timing device travel	1,700	4.5~ 4.9 (mm)		
1-2 Supply pump pressure	1,700	5.7~ 6.3 (kg/cm ²)		
1-3 Full load delivery without charge air pressure	1,000	37.6~38.6 (cc/1,000st)		3.0
Full load delivery with charge air pressure		(cc/1,000st)		
1-4 Idle speed regulation	300	4.3~ 8.3 (cc/1,000st)		2.0
1-5 Start	100	55.0~90.0 (cc/1,000st)		
1-6 Full-load speed regulation	2,300	14.7~20.7 (cc/1,000st)		
1-7				
1-8				

2. Test Specifications

2-1 Timing device	N = rpm mm	1,000 1.4~ 2.6	1,700 4.4~ 5.0	2,150 6.1~ 7.1
2-2 Supply pump	N = rpm kg/cm ²	600 3.0~ 3.6	1,700 5.7~ 6.3	2,150 6.8~ 7.4
2-3 Overflow delivery	N = rpm cc/10s	1,000 8.0~52		

2-4 Fuel injection quantities

Speed control lever position	Pump speed (rpm)	Fuel delivery (cc/1,000st)	Charge air press(mmHg)	Difference in delivery(cc)
Full speed position	1,000	37.1~39.1		
	600	32.2~36.2		
	2,150	32.5~36.7		
	2,300	14.2~21.2		
	2,450	Below 5		
Switch OFF	300	0		
Idling position	300	4.3~8.3		
	350	Below 3		
2-5 Solenoid	Max.cut-in voltage : 8 V Test voltage : 12~14 V			

3. Dimensions

K	3.2~3.4 mm
KF	5.7~5.9 mm
MS	1.4~1.6 mm
BCS	- mm
Control lever angle	
α	21.0~29.0 deg
A	4.0~9.2 mm
β	41.0~51.0 deg
B	12.1~16.1 mm
γ	- deg
C	- mm

Prüfwerte Verteiler- Einspritzpumpen

PRÜF ÖL:
I S O 4113 od
S A E J967d

MOTOR : SD23

Einspritzpumpe Nr: 104640-4240 (NP-VE4/10F2150RNP145)

Dreh-richtung von : seite des Antrieb

Vorhub-Einstellung : - mm

BOSCH Nr. 9 460 610 009

DKKC Nr. 104740-4380

Datum : 20. Nov. 1986

Firma : NISSAN DIESEL

Nr. 16700 09W03

Für Prüfbedingung
Siehe M/K WP210(N-16)

1. Einstellwerte	Drehzahl min ⁻¹	Einstellwerte	Ladedruck bar(mmHg)	Mengenunter-schied(cc)
1-1 Spritzverstellerweg	1,700	4.5~ 4.9 (mm)		
1-2 Förderpumpendruck	1,700	5.7~ 6.3 (kg/cm ²)		
1-3 Vollastmenge ohne ladedruck	1,000	37.6~38.6 (cc/1000Hübe)		3.0
Vollastmenge mit ladedruck		(cc/1000Hübe)		
1-4 Leerlauf-Abregelung	300	4.3~ 8.3 (cc/1000Hübe)		2.0
1-5 Start	100	55.0~90.0 (cc/1000Hübe)		
1-6 End-Abregelung	2,300	14.7~20.7 (cc/1000Hübe)		
1-7				
1-8				

2. Prüfwerte

2-1 Spritzversteller	N = min ⁻¹ mm	1,000 1.4~ 2.6	1,700 4.4~ 5.0	2,150 6.1~ 7.1
2-2 Förderpumpe	N = min ⁻¹ kg/cm ²	600 3.0~ 3.6	1,700 5.7~ 6.3	2,150 6.8~ 7.4
2-3 Überlaufmenge	N = min ⁻¹ cc/10s	1,000 8.0~52		

2-4 Fördermengen

Verstellhebellage	Drehzahl min ⁻¹	Fördermenge (cc/1000Hübe)	Ladedruck bar(mmHg)	Mengenunter-schied(cc)
Endanschlag	1,000	37.1~39.1		
	600	32.2~36.2		
	2,150	32.5~36.7		
	2,300	14.2~21.2		
	2,450	Unter 5		
Abstellung	300	0		
Leerlauf-anschlag	300	4.3~8.3		
	350	Unter 3		
2-5 Magnet	Einschaltspannung max. 8 V Prüfspannung 12~14 V			

3. Maße

K	3.2~3.4 mm
KF	5.7~5.9 mm
MS	1.4~1.6 mm
LDA	- mm
Winkel des Verstellhebel	
α	21.0~29.0 Winkel
A	4.0~9.2 mm
β	41.0~51.0 Winkel
B	12.1~16.1 mm
γ	- Winkel
C	- mm

INJ. PUMP CALIBRATION DATA

Distributor-type

TEST OIL:
ISO 4113 or
SAE J967d

ENGINE MODEL : S2

BOSCH No. 9 460 610 180
DKKC No. 104748-0060
Date : 20.Nov.1986 Q
Company : MAZDA
No. S209 13 800A

104748-0060

Injection pump No: 104648-0060 (NP-VE4/8F2125LNP154)

Pump rotation : Counter clockwise-viewed from drive side

For Test Condition see
Microfiche No.WP-210(N16)

Pre-stroke : - mm

1. Setting	Pump speed (rpm)	Settings	Charge air press(mmHg)	Difference in delivery(cc)
1-1 Timing device travel	1,250	4.0~ 4.4 (mm)		
1-2 Supply pump pressure	1,250	4.4~ 5.0 (kg/cm ²)		
1-3 Full load delivery without charge air pressure	1,250	38.5~39.5 (cc/1,000st)		3.0
Full load delivery with charge air pressure		(cc/1,000st)		
1-4 Idle speed regulation	325	5.2~ 9.2 (cc/1,000st)		2.0
1-5 Start	100	Above 42 (cc/1,000st)		
1-6 Full-load speed regulation	2,400	13.1~17.1 (cc/1,000st)		
1-7				
1-8				

2. Test Specifications

2-1 Timing device	N = rpm mm	1,250 3.9~ 4.5	2,125 8.5~ 9.7
2-2 Supply pump	N = rpm kg/cm ²	500 2.1~ 2.7	1,250 4.4~ 5.0
2-3 Overflow delivery	N = rpm cc/10s	1,250 52.0~95.0	2,125 6.9~ 7.5
2-4 Fuel injection quantities			
Speed control lever position	Pump speed (rpm)	Fuel delivery (cc/1,000st)	Charge air press(mmHg)
Full speed position	1,250	38.0~40.0	
	500	32.6~36.6	
	2,125	34.1~39.1	
	2,400	12.1~18.1	
	2,500	Below 10	
Switch OFF	325	0	
Idling position	325	5.2~ 9.2	
	Below 470	0	
2-5 Solenoid	Max.cut-in voltage : 8 V Test voltage : 12~14 V		

3. Dimensions

K	3.2~3.4	mm
KF	5.7~5.9	mm
MS	1.7~1.9	mm
BSC	-	mm
Control lever angle		
α	34.0~42.0	deg
A	2.5~ 7.7	mm
β	45.0~55.0	deg
B	13.0~17.5	mm
γ	-	deg
C	-	mm

■ M-CSD Assembly and Adjustment

1) Fixing the M-CSD stopper

1. Fix the M-CSD assembly temporarily to the pump housing.
2. Turn the drive shaft at least two turns in the direction of pump rotation.
3. Turn the drive shaft slowly, and fix the drive shaft in a position where a load is applied (the point where the roller in the roller holder contacts the cam surface of the cam disc).
4. Move the CSD lever to the advance side.
5. Fix the CSD lever in the position where the ball pin at the tip of the shaft lightly contacts the roller holder (roller holder advance angle "0").
6. Adjust the stopper position so that the gap between the CSD lever and the stopper is 0.5±2 mm.
7. After adjustment, tighten the M-CSD screw to the specified torque.

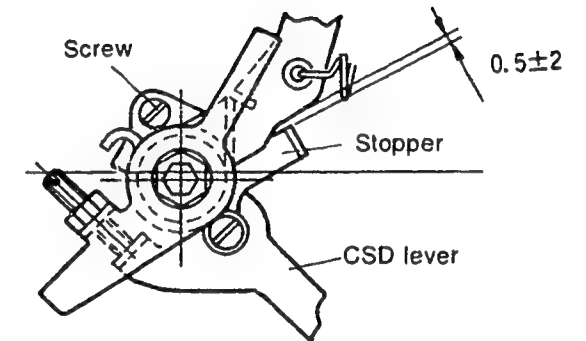

INJ. PUMP CALIBRATION DATA

Distributor-type

TEST OIL:
I S O 4113 or
S A E J967d

ENGINE MODEL : RF

Injection pump No: 104648-0172 (NP-VE4/8F2325LNP216)

Pump rotation : Counter clockwise-viewed from drive side

Pre-stroke : — mm

1/5

BOSCH No.9 460 610 011
DKKC No. 104748-0172
Date : 20.Nov.1986 Q
Company : MAZDA
No. RF11 13 800B

For Test Condition see
Microfiche No.WP-210(N16)

104748-0172 2/5

1. Setting	Pump speed (rpm)	Settings	Charge air press(mmHg)	Difference in delivery(cc)
1-1 Timing device travel	1,375	4.5~ 4.9 (mm)		
1-2 Supply pump pressure	1,375	4.4~ 5.0 (kg/cm ²)		
1-3 Full load delivery without charge air pressure	1,375	35.4~36.4 (cc/1,000st)		2.5
Full load delivery with charge air pressure		(cc/1,000st)		
1-4 Idle speed regulation	410	6.0~10.0 (cc/1,000st)		2.0
1-5 Start	100	Above 42 (cc/1,000st)		
1-6 Full-load speed regulation	2,600	10.8~14.8 (cc/1,000st)		
1-7 Load-timer Adjustment	1,375	4.1±0.2 (mm)		
1-8				

2. Test Specifications

2-1 Timing device	N = rpm	1,375	2,000	2,325	
	mm	4.4~ 5.0	7.8~ 9.0	9.1~10.3	
2-2 Supply pump	N = rpm	600	1,375	2,325	
	kg/cm ²	2.2~ 2.8	4.4~ 5.0	6.9~ 7.5	
2-3 Overflow delivery	N = rpm	1,375			
	cc/10s	46.3~90.3			
2-4 Fuel injection quantities					
Speed control lever position	Pump speed (rpm)	Fuel delivery (cc/1,000st)	Charge air press(mmHg)	Difference in delivery(cc)	
Full speed position	1,375	34.9~36.9			
	600	29.1~33.1			
	2,325	29.2~33.2			
	2,600	9.8~15.8			
	2,700	Below 6.0			
Switch OFF	410	0			
Idling position	410	6.0~10.0			
2-5 Solenoid	Max.cut-in voltage : 8 V Test voltage : 12~14 V				

3. Dimensions

K	3.2~3.4	mm
KF	5.7~5.9	mm
MS	1.4~1.6	mm
BCS	—	mm

Control lever angle

α	16.0~24.0	deg
A	5.7~10.9	mm
β	40.0~50.0	deg
B	12.7~16.0	mm
γ	—	deg
C	—	mm

LOAD TIMER ADJUSTMENT

1) Adjustment

① Fix the control lever in the position satisfying the following conditions.

Boost Pressure : — mmHg
Pump Speed : 1375 rpm
Fuel Injection : 28.2±1 cc/1000st
Quantity

② With the control lever positioned as described in ① above, adjust the governor sleeve so that the Timer Stroke conforms to the specified values (page 1/5)

2) Confirmation of Timer Characteristics

Fix the control lever in the position satisfying the following conditions, and confirm the Timer Stroke.

Control lever position			Specified Values	
Pump speed (rpm)	Fuel Injection Quantity(cc/1000st)	Boost pressure (mmHg)	Timer stroke (mm)	Timer stroke reduction value (mm)
1375	28±1.5	—	4.1±0.3	—
1375	16±1.5	—	(2.9)	—

Side Link Lever Adjustment

1) Side link lever adjustment

1. Fix the control lever in the idling position.
2. Check that side link levers (1) and (2) contact the stoppers. (Portion A)

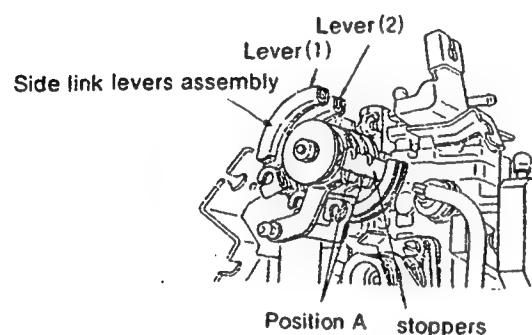

3. If control lever (4) and lever (3) are not connected by rod (5), connect them.
4. After connecting rod (5), adjust the length of rod (5) so that the gap at the hook of lever (3) and levers (1) and (2) is 0.5 ± 1 mm.

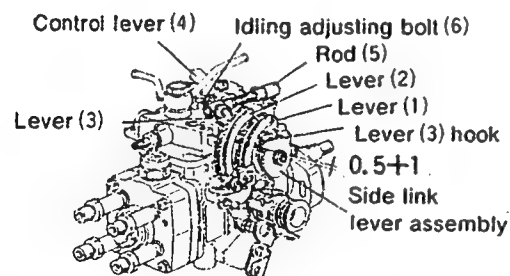

2) M-CSD adjustment

1. Loosen M-CSD lock screw (7).
2. Turn the drive shaft two or three turns and set the measuring device at 0.

3. Move the CSD lever gently in the direction of the arrow (advance direction).
4. Fix the CSD lever in a position where the CSD lever shaft ball pin contacts the roller holder. (Move gently, and hold the CSD lever in the position where the resistance changes.)
5. Check that the measuring device is at the 0 point.
6. Adjust the position of the stopper so that the gap between CSD lever (8) and stopper (9) is 0.5 ± 2 mm, and then fix in position using screw (7).
7. Turn the drive shaft two or three turns, check the position of the measuring device 0 point, and then recheck the gap between CSD lever (8) and stopper (9).

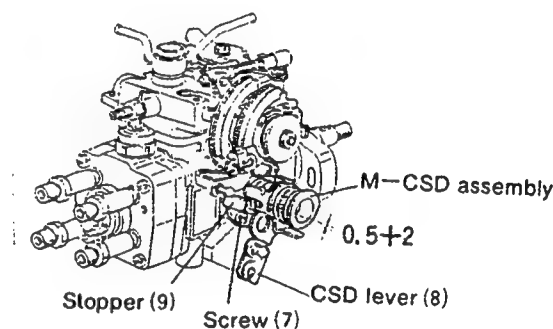
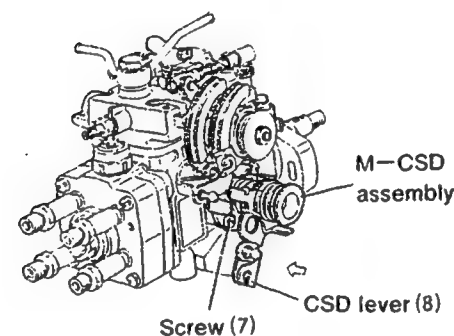

3) Fixing the CSD lever and side link lever connecting rod

1. Connect the side link lever assembly and CSD lever using rod (10).
2. Move the CSD lever through its full stroke (in the direction the arrow).
3. Adjust the length of rod (10) so that the gap between control lever (4) and idling adjusting bolt (6) is 6.4 mm, and then fix in this position.

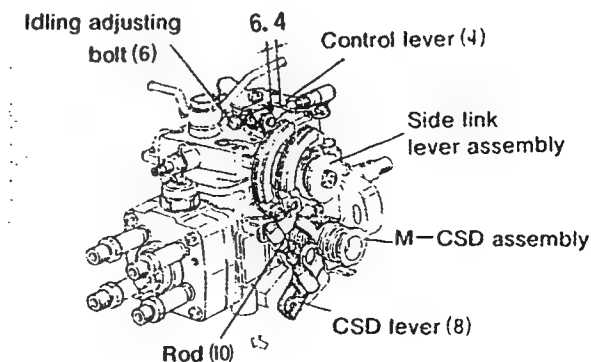

104748-0172 5/5

TEST OIL:
I S O 4113 or
S A E J967d

INJ. PUMP CALIBRATION DATA Distributor-type

ENGINE MODEL : CD17

1/7

BOSCH No.9 460 610 148
DKKC No. 104748-2050
Date : 20.Nov.1986 0
Company : NISSAN
No. 16700 17A05

Injection pump No: 104648-2020 [NP-VE4/8F2500LNP177]

Pump rotation : Counter clockwise-viewed from drive side

Pre-stroke : - mm

For Test Condition see
Microfiche No.WP-210(N16)

4) Fixing the engine installation bracket

1. Fix the bracket temporarily to the pump.
2. Move the bracket in the direction of the arrow until the clearance is 0.
3. Fix the bracket in position using the bolts.

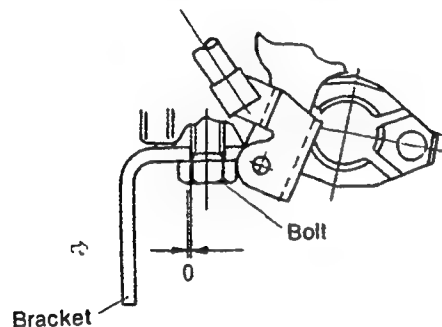

1. Setting		Pump speed (rpm)	Settings	Charge air press(mmHg)	Difference in delivery(cc)
1-1	Timing device travel	1,200	2.3~ 2.9 (mm)		
1-2	Supply pump pressure	1,200	3.1~ 3.7 (kg/cm ²)		
1-3	Full load delivery without charge air pressure	1,200	28.6~29.6 (cc/1,000st)		2.5
	Full load delivery with charge air pressure		(cc/1,000st)		
1-4	Idle speed regulation	400	8.3~11.3 (cc/1,000st)		3.0
1-5	Start	100	45.3~55.3 (cc/1,000st)		
1-6	Full-load speed regulation	2,700	11.9~17.9 (cc/1,000st)		
1-7	ACS Adjustment	1,200	Decrease 2.1~ 3.1 (cm/1,000st)	-140	
1-8					

2. Test Specifications

2-1	Timing device	N = rpm mm	1,200 2.2~ 3.0	1,800 4.3~ 5.5	2,500 7.4~ 8.6
2-2	Supply pump	N = rpm kg/cm ²	1,200 3.0~ 3.8	1,800 4.4~ 5.2	2,500 6.1~ 6.9
2-3	Overflow delivery	N = rpm cc/10s	1,200 36.0~80.0		

2-4 Fuel injection quantities

Speed control lever position	Pump speed (rpm)	Fuel delivery (cc/1,000st)	Charge air press(mmHg)	Difference in delivery(cc)
Full speed position	1,200	28.1~30.1	-140±5	
	600	24.3~28.3		
	1,200	Decrease 1.1~ 4.1		
	2,500	25.7~29.7		
	2,700	11.4~18.4		
	2,900	Below 6		
Switch OFF	400	0		
Idling position	400	7.8~11.8		
	600	Below 3		
Partial load	700	13.3~20.0		
2-5 Solenoid	Max.cut-in voltage : 8 V Test voltage : 12~14 V			

3. Dimensions

K	3.2~3.4 mm
KF	5.7~5.9 mm
MS	1.5~1.7 mm
∅CS	- mm

Control lever angle

α	20.0~28.0 deg
A	3.2~ 8.3 mm
β	37.0~47.0 deg
B	10.8~14.9 mm
γ	10.5~11.5 deg
C	6.7~ 7.3 mm



DIESEL KIKI

DIESEL KIKI CO., LTD.

Service Department

3-6-7 SHIBUYA, SHIBUYA-KU, TOKYO 150, JAPAN
Tel. (03) 400-1551 · Fax: (03) 499-4115

■ Starting Injection Quantity Adjustment

Adjust the starting injection quantity (item 1/5) using the adjusting bolt (as shown in the figure at right) .

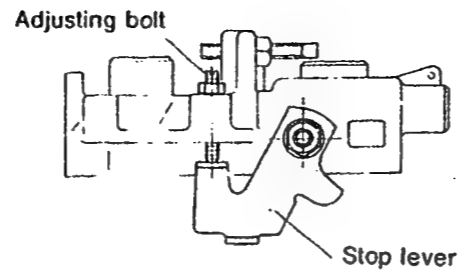

■ POTENTIOMETER ADJUSTMENT

Under the following conditions, after potentiometer installation position so that the out-put voltage equale the specified value.

Adjustment Conditions			Specified Value	Remarks
Control lever position	Pump speed (rpm)	Fuel Injection Quantity(cc/1000st)	Adjustment Value Out-put voltage (V)	
(Approx 11°)	700	Reference graph	Reference graph	Adjusting point
Idel	—	—	—	Check point
Full speed	—	—	—	Check point

[In-put Voltage:10V]

※ A control lever position of approximately 11° , means that a block gauge of 7 mm thickness is inserted between the control lever and the idling stopper bolt.

■ Plug positions

The plug (146616-0900) installation (shown below), depends on the value of control lever angle β .

Position A : When $37^\circ(10.8\text{mm}) \leq \beta (B) \leq 41^\circ(12.4\text{mm})$

Position B : When $41^\circ(12.4\text{mm}) \leq \beta (B) \leq 47^\circ(14.7\text{mm})$

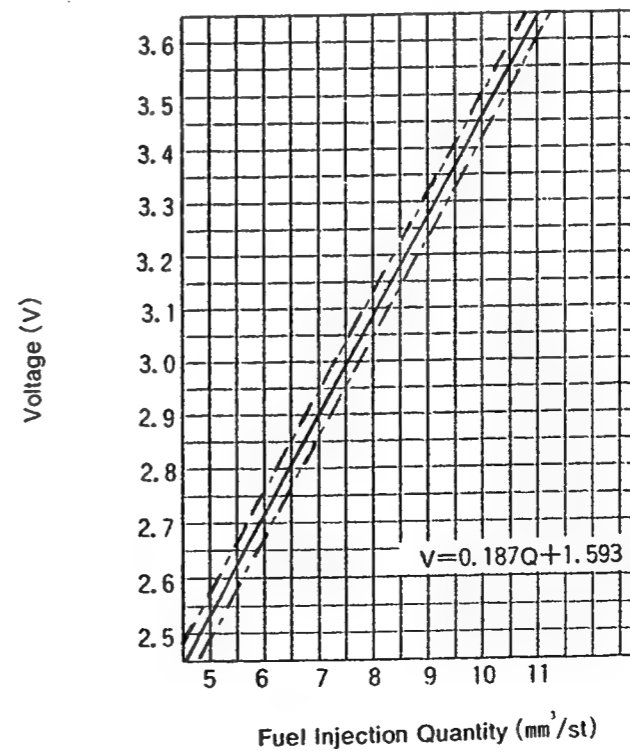
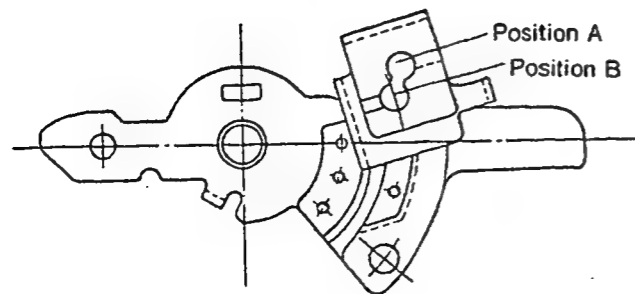
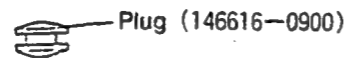

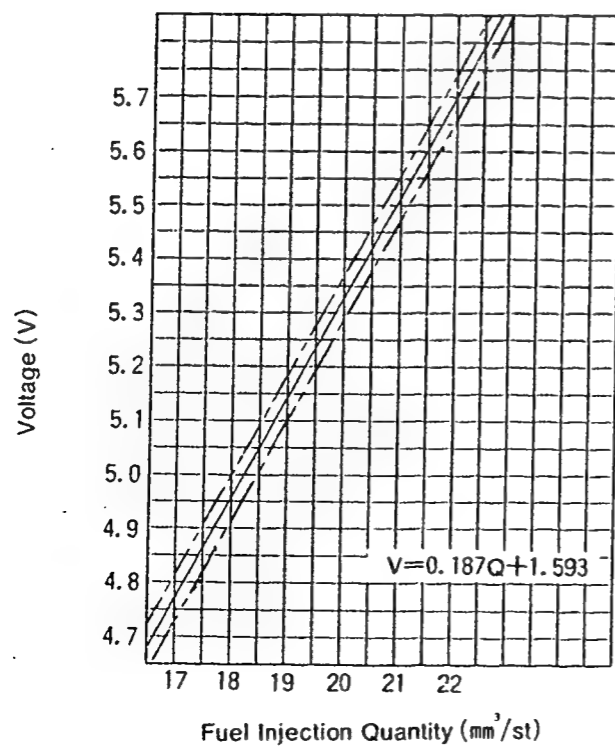
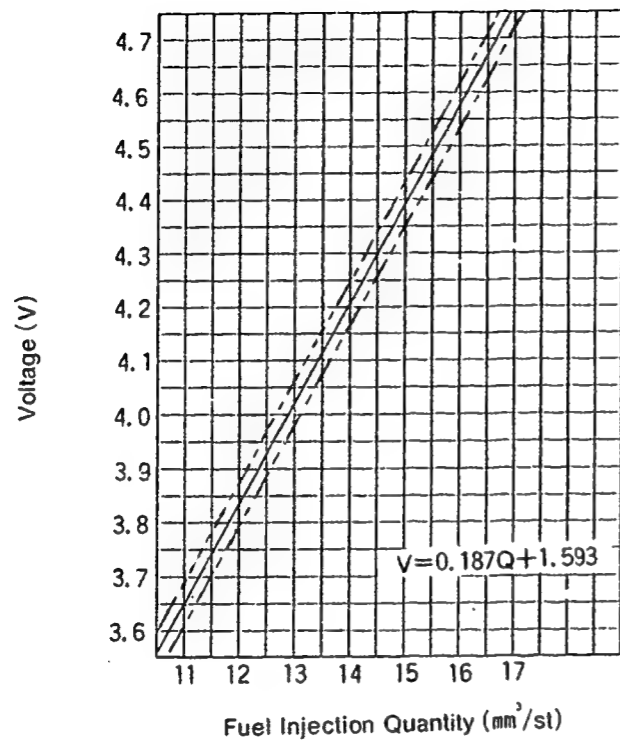

■ W-CSD Adjustment

1) Timer stroke adjustment

1. Calculate the timer stroke from Fig. 2 according to the atmospheric temperature at the time of adjustment.
2. Adjust using timer stroke adjusting screw so that the timer stroke is as calculated in Step 1.

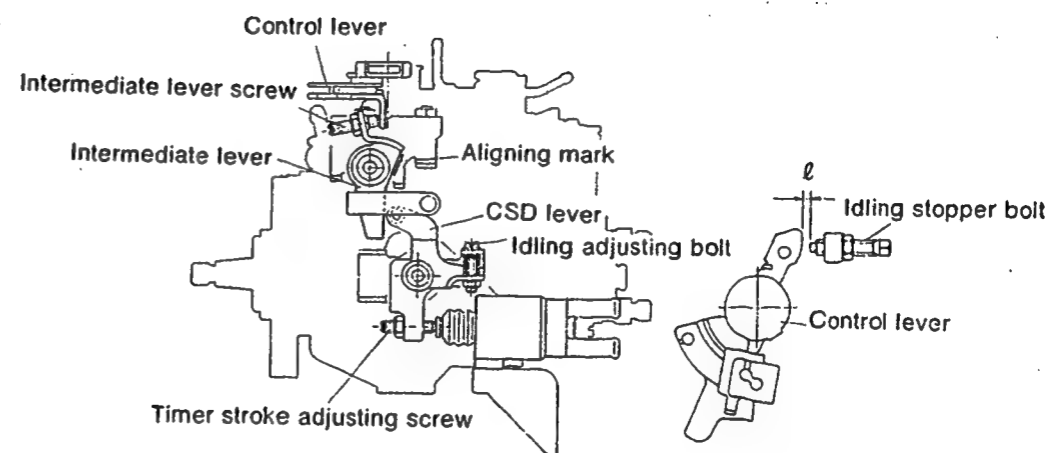

Fig. 1

2) Intermediate lever position adjustment

1. Insert a block gauge (thickness gauge) of 1.0 ± 0.05 mm thickness between the control lever and the idling stopper bolt.
2. Align the intermediate lever with the aligning mark.
3. Adjust the intermediate lever set screw so that the control lever and intermediate lever set screw are in contact, and then fix in position using the locknut.

3) CSD lever adjustment

1. Calculate the block gauge dimension $\ell \pm 0.05\text{mm}$ from Fig. 2 according to the atmospheric temperature at the time of adjustment.
2. Insert the block gauge (thickness gauge) between the control lever and the idling stopper bolt.
3. Using the idling bolt, adjust so that the CSD lever roller and intermediate lever are in contact.

Formula for calculating Fig. 2

Formula for calculating timer stroke:

When $-10 \leq t \leq 20$: $T = -0.0284t + 1.367$

When $20 \leq t \leq 60$: $T = -0.02t + 1.2$

Formula for calculating control lever and idling stopper bolt gap:

When $-10 \leq t \leq 20$: $\ell = -0.0667t + 3.23$

When $20 \leq t \leq 60$: $\ell = -0.05t + 2.9$

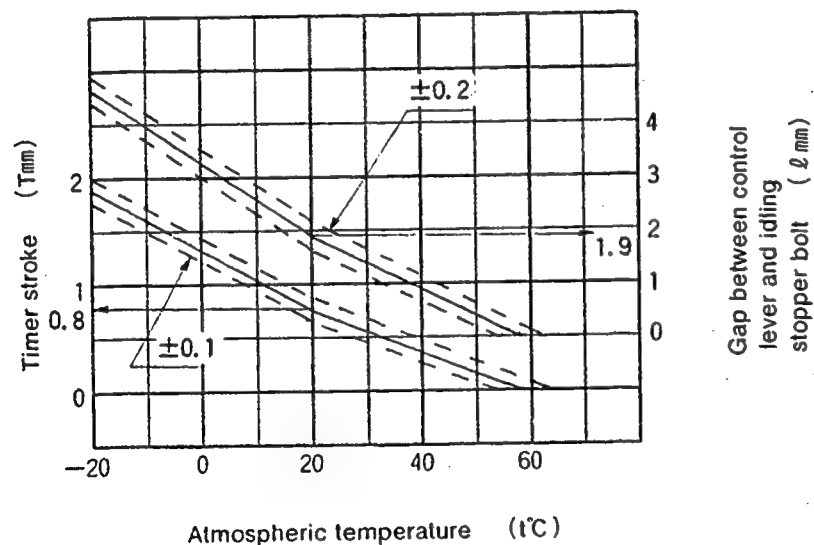

Fig. 2

■ FULL-LOAD FUEL INJECTION QUANTITY AND ACS ADJUSTING PROCEDURE AT ALTITUDE

1) FULL-LOAD FUEL INJECTION QUANTITY ADJUSTMENT

- ① Remove the ACS cover, bellow and adjusting shims.
- ② Perform all adjustments as described in the adjusting specifications, except for ACS adjustment.

2) ACS ADJUSTMENT

- ① Attach the ACS cover, bellows and adjusting shims.
- ② At pump speed of 1200 rpm and referring to the graph below, use the shims to adjust the fuel injection quantity decrease quantity according to altitude.

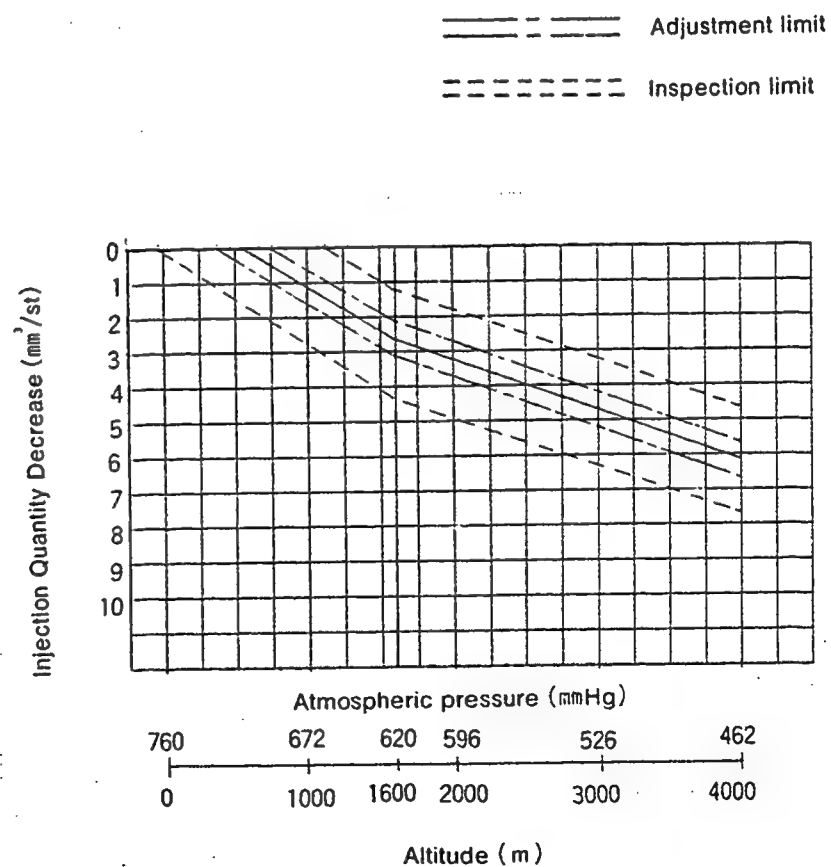

INJ. PUMP CALIBRATION DATA

Distributor-type

1/4
 BOSCH No. 9 460 610 056
 DKKC No. 104748-2061
 Date : 20.Nov.1986 2
 Company : NISSAN
 No. 16700 16A65

TEST OIL:
 I S O 4113 or
 S A E J967d

ENGINE MODEL : CD17

Injection pump No: 104648-2016 [NP-VE4/8F2500LNP164]

Pump rotation : Counter clockwise-viewed from drive side
 Pre-stroke : - mm

For Test Condition see
 Microfiche No.WP-210(N16)

1. Setting	Pump speed (rpm)	Settings	Charge air press(mmHg)	Difference in delivery(cc)
1-1 Timing device travel	1,200	1.8~ 2.4 (mm)		
1-2 Supply pump pressure	1,200	3.1~ 3.7 (kg/cm ²)		
1-3 Full load delivery without charge air pressure	1,200	29.5~30.5 (cc/1,000st)		2.5
Full load delivery with charge air pressure		(cc/1,000st)		
1-4 Idle speed regulation	400	8.3~11.3 (cc/1,000st)		3.0
1-5 Start	100	45.3~55.3 (cc/1,000st)		
1-6 Full-load speed regulation	2,700	11.9~17.9 (cc/1,000st)		
1-7				
1-8				

2. Test Specifications

2-1 Timing device	N = rpm	1,200	1,800	2,500
	mm	1.7~ 2.5	4.0~ 5.2	6.8~ 8.0
2-2 Supply pump	N = rpm	1,200	1,800	2,500
	kg/cm ²	3.0~ 3.8	4.4~ 5.2	6.1~ 6.9
2-3 Overflow delivery	N = rpm	1,200		
	cc/10s	36.0~80.0		
2-4 Fuel injection quantities				
Speed control lever position	Pump speed (rpm)	Fuel delivery (cc/1,000st)	Charge air press(mmHg)	Difference in delivery(cc)
Full speed position	1,200	29.0~31.0		
	600	24.8~28.8		
	2,500	26.7~30.7		
	2,700	11.4~18.4		
	2,900	Below 6		
Switch OFF	400	0		
Idling position	400	7.8~11.8		
	600	Below 3		
Partial load	700	13.3~20.0		
2-5 Solenoid	Max.cut-in voltage : 8 V Test voltage : 12~14 V			

3. Dimensions

K	3.2~3.4	mm
KF	5.7~5.9	mm
MS	1.5~1.7	mm
BCS	-	mm

Control lever angle

α	21.0~29.0	deg
A	2.5~ 8.0	mm
β	37.0~47.0	deg
B	10.7~14.8	mm
γ	10.5~11.5	deg
C	6.7~ 7.3	mm

Starting Injection Quantity Adjustment

Adjust the starting injection quantity (Item 1/5) using the adjusting bolt (as shown in the figure at right).

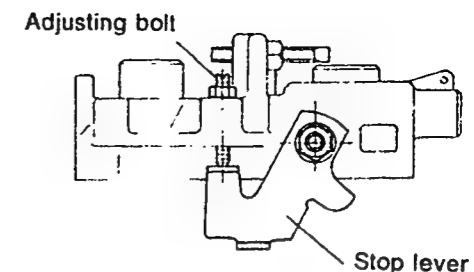

Plug positions

The plug (146616-0900) installation (shown below), depends on the value of control lever angle β

Position A : When $37^\circ(10.7\text{mm}) \leq \beta(B) < 41^\circ(12.4\text{mm})$

Position B : When $41^\circ(12.4\text{mm}) \leq \beta(B) \leq 47^\circ(14.8\text{mm})$

Plug (146616-0900)

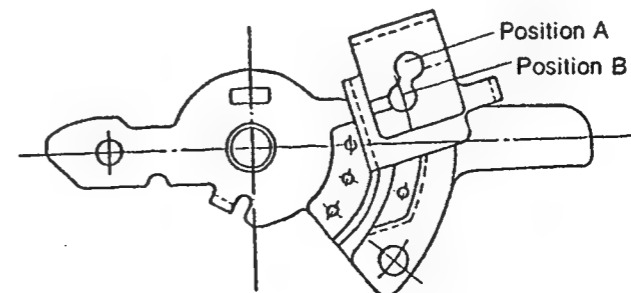

■ W-CSD Adjustment

1) Timer stroke adjustment

1. Calculate the timer stroke from Fig. 2 according to the atmospheric temperature at the time of adjustment.
2. Adjust using timer stroke adjusting screw so that the timer stroke is as calculated in Step 1.

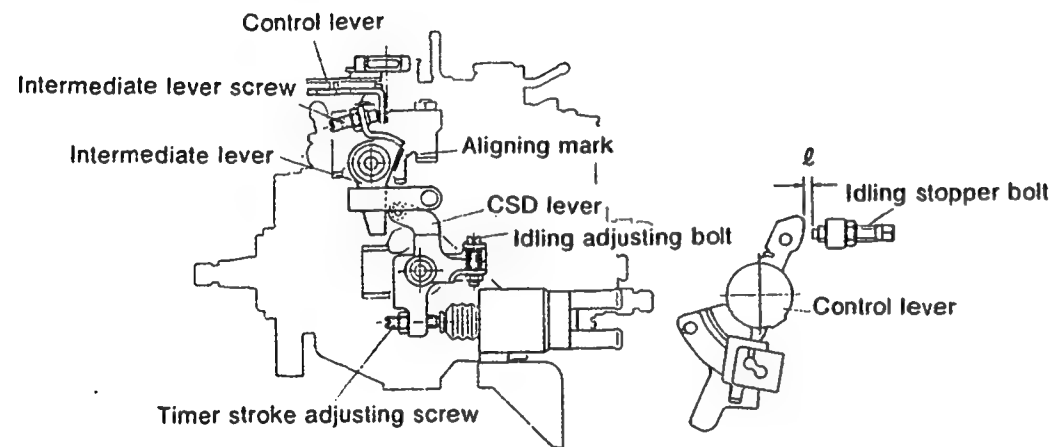

Fig. 1

2) Intermediate lever position adjustment

1. Insert a block gauge (thickness gauge) of 1.0 ± 0.05 mm thickness between the control lever and the idling stopper bolt.
2. Align the intermediate lever with the aligning mark.
3. Adjust the intermediate lever set screw so that the control lever and intermediate lever set screw are in contact, and then fix in position using the locknut.

3) CSD lever adjustment

1. Calculate the block gauge dimension $l \pm 0.05$ mm from Fig. 2 according to the atmospheric temperature at the time of adjustment.
2. Insert the block gauge (thickness gauge) between the control lever and the idling stopper bolt.
3. Using the idling bolt, adjust so that the CSD lever roller and intermediate lever are in contact.

Formula for calculating Fig. 2

Formula for calculating timer stroke:

When $-10 \leq t \leq 20$: $T = -0.0284t + 1.367$

When $20 \leq t \leq 60$: $T = -0.02t + 1.2$

Formula for calculating control lever and idling stopper bolt gap:

When $-10 \leq t \leq 20$: $l = -0.0667t + 3.23$

When $20 \leq t \leq 60$: $l = -0.05t + 2.9$

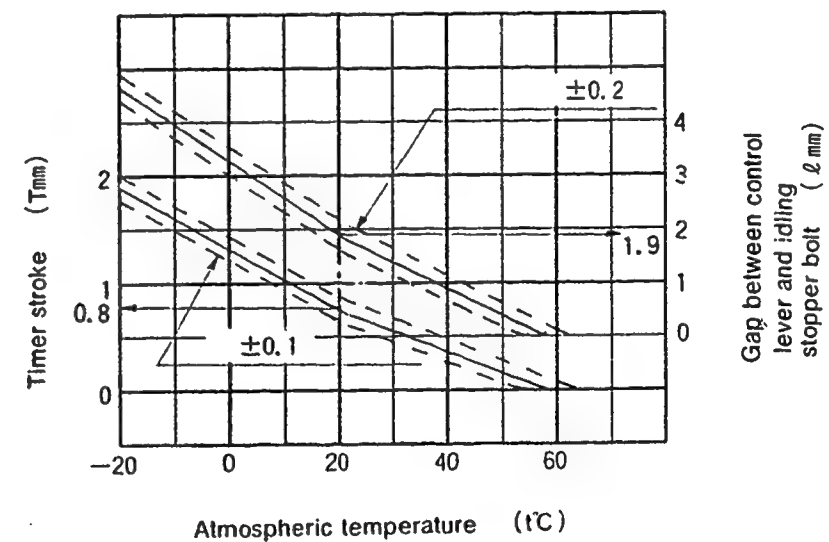

Fig. 2

INJ. PUMP CALIBRATION DATA

Distributor-type

1/4

BOSCH No.9 460 610 057
 DKKC No. 104748-2081
 Date: 20.Nov.1986 2
 Company: NISSAN
 No. 16700 16A75

TEST OIL:
 I S O 4113 or
 S A E J967d

ENGINE MODEL : CD17

Injection pump No: 104648-2061 [NP-VE4/8F2500LNP164]

Pump rotation : Counter clockwise-viewed from drive side

For Test Condition see
 Microfiche No.WP-210(N16)

Pre-stroke : - mm

1. Setting	Pump speed (rpm)	Settings	Charge air press(mmHg)	Difference in delivery(cc)
1-1 Timing device travel	1,200	1.8~ 2.4 (mm)		
1-2 Supply pump pressure	1,200	3.1~ 3.7 (kg/cm ²)		
1-3 Full load delivery without charge air pressure	1,200	29.5~30.5 (cc/1,000st)		2.5
Full load delivery with charge air pressure		(cc/1,000st)		
1-4 Idle speed regulation	400	8.3~11.3 (cc/1,000st)		3.0
1-5 Start	100	45.3~55.3 (cc/1,000st)		
1-6 Full-load speed regulation	2,700	11.9~17.9 (cc/1,000st)		
1-7				
1-8				

2. Test Specifications

2-1 Timing device	N = rpm	1,200	1,800	2,500
	mm	1.7~ 2.5	4.0~ 5.2	6.8~ 8.0
2-2 Supply pump	N = rpm	1,200	1,800	2,500
	kg/cm ²	3.0~ 3.8	4.4~ 5.2	6.1~ 6.9
2-3 Overflow delivery	N = rpm	1,200		
	cc/10s	36.0~80.0		
2-4 Fuel injection quantities				
Speed control lever position	Pump speed (rpm)	Fuel delivery (cc/1,000st)	Charge air press(mmHg)	Difference in delivery(cc)
Full speed position	1,200	29.0~31.0		
	600	24.8~28.8		
	2,500	26.7~30.7		
	2,700	11.4~18.4		
	2,900	Below 6		
Switch OFF	400	0		
Idling position	400	7.8~11.8		
	600	Below 3		
Partial load	700	13.3~20.0		
2-5 Solenoid	Max.cut-in voltage : 8 V Test voltage : 12~14 V			

3. Dimensions

K	3.2~3.4 mm
KF	5.7~5.9 mm
MS	1.5~1.7 mm
BCS	- mm

Control lever angle

α	21.0~29.0 deg
A	2.5~ 8.0 mm
β	37.0~47.0 deg
B	10.7~14.8 mm
γ	10.5~11.5 deg
C	6.7~ 7.3 mm

Starting Injection Quantity Adjustment

Adjust the starting injection quantity (item 1/5) using the adjusting bolt (as shown in the figure at right).

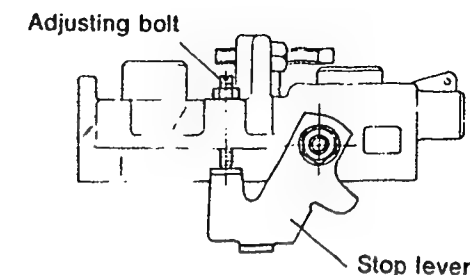

Plug positions

The plug (146616-0900) installation (shown below), depends on the value of control lever angle β.

Position A : When $37^\circ(10.7\text{mm}) \leq \beta(B) < 41^\circ(12.4\text{mm})$

Position B : When $41^\circ(12.4\text{mm}) \leq \beta(B) \leq 47^\circ(14.8\text{mm})$

Plug (146616-0900)

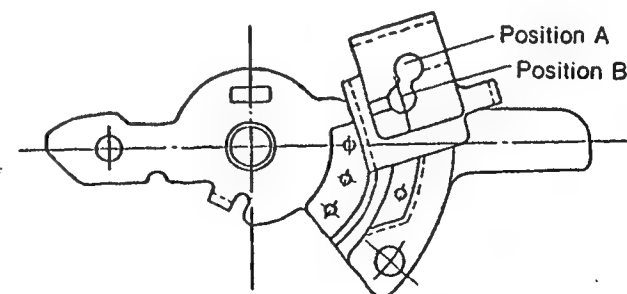

■ W-CSD Adjustment

1) Timer stroke adjustment

1. Calculate the timer stroke from Fig. 2 according to the atmospheric temperature at the time of adjustment.
2. Adjust using timer stroke adjusting screw so that the timer stroke is as calculated in Step 1.

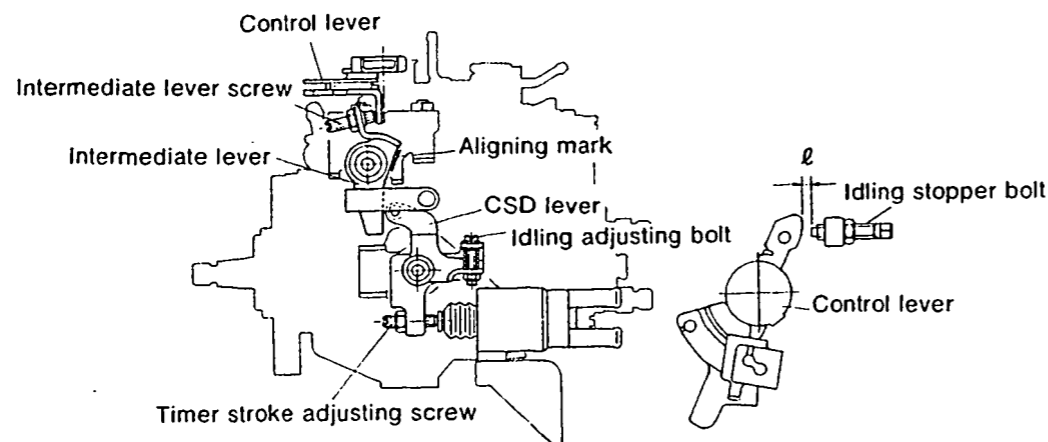

Fig. 1

2) Intermediate lever position adjustment

1. Insert a block gauge (thickness gauge) of 1.0 ± 0.05 mm thickness between the control lever and the idling stopper bolt.
2. Align the intermediate lever with the aligning mark.
3. Adjust the intermediate lever set screw so that the control lever and intermediate lever set screw are in contact, and then fix in position using the locknut.

3) CSD lever adjustment

1. Calculate the block gauge dimension $l \pm 0.05$ mm from Fig. 2 according to the atmospheric temperature at the time of adjustment.
2. Insert the block gauge (thickness gauge) between the control lever and the idling stopper bolt.
3. Using the idling bolt, adjust so that the CSD lever roller and intermediate lever are in contact.

Formula for calculating Fig. 2

Formula for calculating timer stroke:

When $-10 \leq t \leq 20$: $T = -0.0284t + 1.367$

When $20 \leq t \leq 60$: $T = -0.02t + 1.2$

Formula for calculating control lever and idling stopper bolt gap:

When $-10 \leq t \leq 20$: $l = -0.0667t + 3.23$

When $20 \leq t \leq 60$: $l = -0.05t + 2.9$

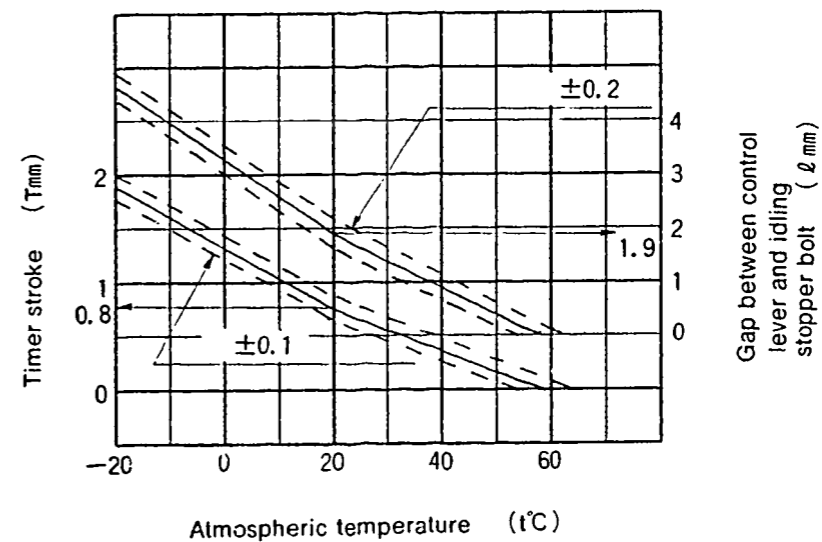

Fig. 2

INJ. PUMP CALIBRATION DATA

Distributor-type

1/4
 BOSCH No.9 460 610 053
 DKKC No. 104748-2140
 Date: 20.Nov.1986 [2]
 Company: NISSAN
 No. 16700 16A61

TEST OIL:
 I S O 4113 or
 S A E J967d

ENGINE MODEL : CD17

Injection pump No: 104648-2090 [NP-VE4/8F2500LNP164]

Pump rotation : Counter clockwise-viewed from drive side

Pre-stroke : - mm

For Test Condition see
 Microfiche No.WP-210(N16)

1. Setting	Pump speed (rpm)	Settings	Charge air press(mmHg)	Difference in delivery(cc)
1-1 Timing device travel	1,200	1.8~ 2.4 (mm)		
1-2 Supply pump pressure	1,200	3.1~ 3.7 (kg/cm ²)		
1-3 Full load delivery without charge air pressure	1,200	29.5~30.5 (cc/1,000st)		2.5
Full load delivery with charge air pressure		(cc/1,000st)		
1-4 Idle speed regulation	400	5.3~ 8.3 (cc/1,000st)		3.0
1-5 Start	100	45.3~55.3 (cc/1,000st)		
1-6 Full-load speed regulation	2,700	11.9~17.9 (cc/1,000st)		
1-7				
1-8				

2. Test Specifications

2-1 Timing device	N = rpm mm	1,200 1.7~ 2.5	1,800 4.0~ 5.2	2,500 6.8~ 8.0
2-2 Supply pump	N = rpm kg/cm ²	1,200 3.0~ 3.8	1,800 4.4~ 5.2	2,500 6.1~ 6.9
2-3 Overflow delivery	N = rpm cc/10s	1,200 36.0~80.0		
2-4 Fuel injection quantities				
Speed control lever position	Pump speed (rpm)	Fuel delivery (cc/1,000st)	Charge air press(mmHg)	Difference in delivery(cc)
Full speed position	1,200	29.0~31.0		
	600	24.8~28.8		
	2,500	26.7~30.7		
	2,700	11.4~18.4		
	2,900	Below 6		
Switch OFF	400	0		
Idling position	400	4.8~ 8.8		
	600	Below 3		
Partial load	700	10.0~20.0		
2-5 Solenoid	Max.cut-in voltage : 8 V Test voltage : 12~14 V			

3. Dimensions

K	3.2~3.4 mm
KF	5.7~5.9 mm
MS	1.5~1.7 mm
BCS	- mm

Control lever angle

α	21.0~29.0 deg
A	2.5~ 8.0 mm
β	39.0~49.0 deg
B	11.0~16.0 mm
γ	13.5~14.5 deg
C	8.6~ 9.2 mm

Starting Injection Quantity Adjustment

Adjust the starting injection quantity (item 1/5) using the adjusting bolt (as shown in the figure at right).

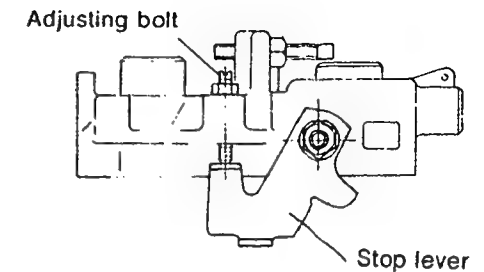

■ W-CSD Adjustment

1) Timer stroke adjustment

1. Calculate the timer stroke from Fig. 2 according to the atmospheric temperature at the time of adjustment.
2. Adjust using timer stroke adjusting screw so that the timer stroke is as calculated in Step 1.

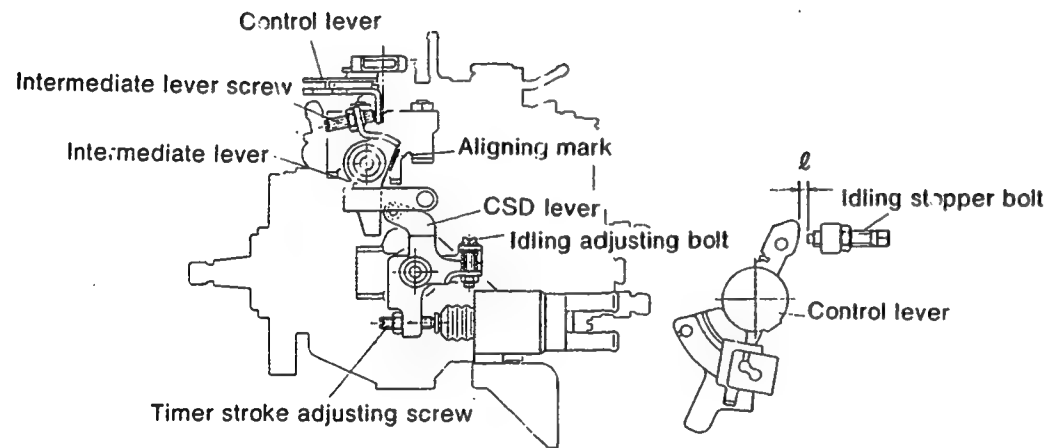

Fig. 1

2) Intermediate lever position adjustment

1. Insert a block gauge (thickness gauge) of 1.0 ± 0.05 mm thickness between the control lever and the idling stopper bolt.
2. Align the intermediate lever with the aligning mark.
3. Adjust the intermediate lever set screw so that the control lever and intermediate lever set screw are in contact, and then fix in position using the locknut.

3) CSD lever adjustment

1. Calculate the block gauge dimension $l \pm 0.05$ mm from Fig. 2 according to the atmospheric temperature at the time of adjustment.
2. Insert the block gauge (thickness gauge) between the control lever and the idling stopper bolt.
3. Using the idling bolt, adjust so that the CSD lever roller and intermediate lever are in contact.

Formula for calculating Fig. 2

Formula for calculating timer stroke:

When $-10 \leq t \leq 20$: $T = -0.0284t + 1.367$

When $20 \leq t \leq 60$: $T = -0.02t + 1.2$

Formula for calculating control lever and idling stopper bolt gap:

When $-10 \leq t \leq 20$: $l = -0.0667t + 3.23$

When $20 \leq t \leq 60$: $l = -0.05t + 2.9$

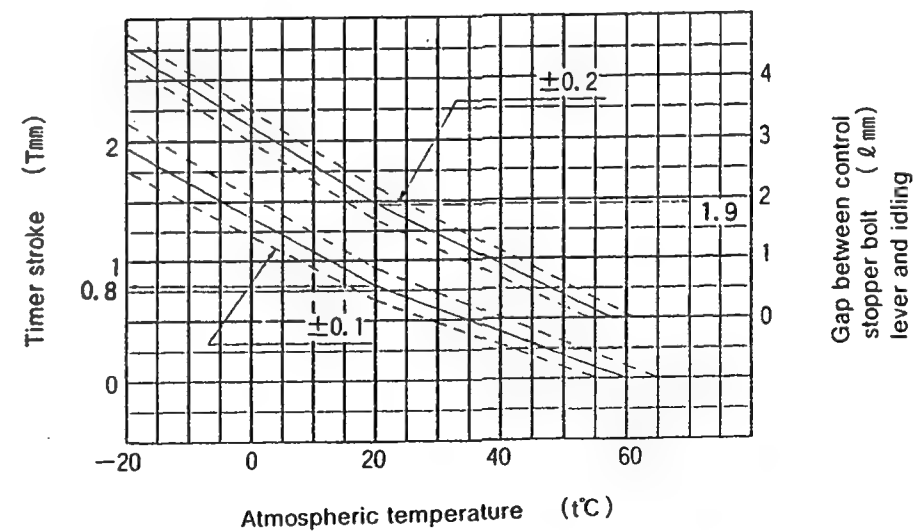

Fig. 2

INJ. PUMP CALIBRATION DATA

Distributor-type

TEST OIL:
ISO 4113 or
SAE J967d

ENGINE MODEL : CD17

1/4
BOSCH No.9 460 610 060
DKKC No. 104748-2160
Date : 20.Nov.1986 [2]
Company : NISSAN
No. 16700 16A71

Injection pump No: 104648-2090 (NP-VE4/8F2500LNP164)

Pump rotation : Counter clockwise-viewed from drive side

For Test Condition see
Microfiche No.WP-210(N16)

Pre-stroke : - mm

1. Setting	Pump speed (rpm)	Settings	Charge air press(mmHg)	Difference in delivery(cc)
1-1 Timing device travel	1,700	4.5~ 4.9 (mm)		
1-2 Supply pump pressure	1,700	5.6~ 6.2 (kg/cm ²)		
1-3 Full load delivery without charge air pressure	1,000	35.6~36.6 (cc/1,000st)		3.0
Full load delivery with charge air pressure		(cc/1,000st)		
1-4 Idle speed regulation	300	4.3~ 8.3 (cc/1,000st)		2.0
1-5 Start	100	55.0~90.0 (cc/1,000st)		
1-6 Full-load speed regulation	2,300	14.7~20.7 (cc/1,000st)		
1-7 ACS Adjustment	1,000	5.0~ 6.0	-164±5	
1-8				

2. Test Specifications

2-1 Timing device	N = rpm mm	1,200 1.7~ 2.5	1,800 4.0~ 5.2	2,500 6.8~ 8.0
2-2 Supply pump	N = rpm kg/cm ²	1,200 3.0~ 3.8	1,800 4.4~ 5.2	2,500 6.1~ 6.9
2-3 Overflow delivery	N = rpm cc/10s	1,200 36.0~80.0		

2-4 Fuel injection quantities

Speed control lever position	Pump speed (rpm)	Fuel delivery (cc/1,000st)	Charge air press(mmHg)	Difference in delivery(cc)
Full speed position	1,200	29.0~31.0		
	600	24.8~28.8		
	2,500	26.7~30.7		
	2,700	11.4~18.4		
	2,900	Below 6		
Switch OFF	400	0		
Idling position	400	4.8~ 8.8		
	600	Below 3		
Partial load	700	10.0~20.0		
2-5 Solenoid	Max.cut-in voltage : 8 V Test voltage : 12~14 V			

3. Dimensions

K	3.2~3.4 mm
KF	5.7~5.9 mm
MS	1.5~1.7 mm
BCS	- mm
Control lever angle	
α	21.0~29.0 deg
A	2.5~ 8.0 mm
β	39.0~49.0 deg
B	11.0~16.0 mm
γ	13.5~14.5 deg
C	8.6~ 9.2 mm

Starting Injection Quantity Adjustment

Adjust the starting injection quantity (item 1/5) using the adjusting bolt (as shown in the figure at right).

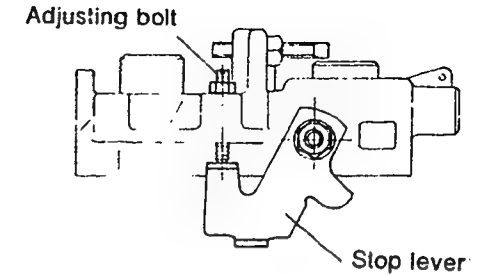

■ W-CSD Adjustment

1) Timer stroke adjustment

1. Calculate the timer stroke from Fig. 2 according to the atmospheric temperature at the time of adjustment.
2. Adjust using timer stroke adjusting screw so that the timer stroke is as calculated in Step 1.

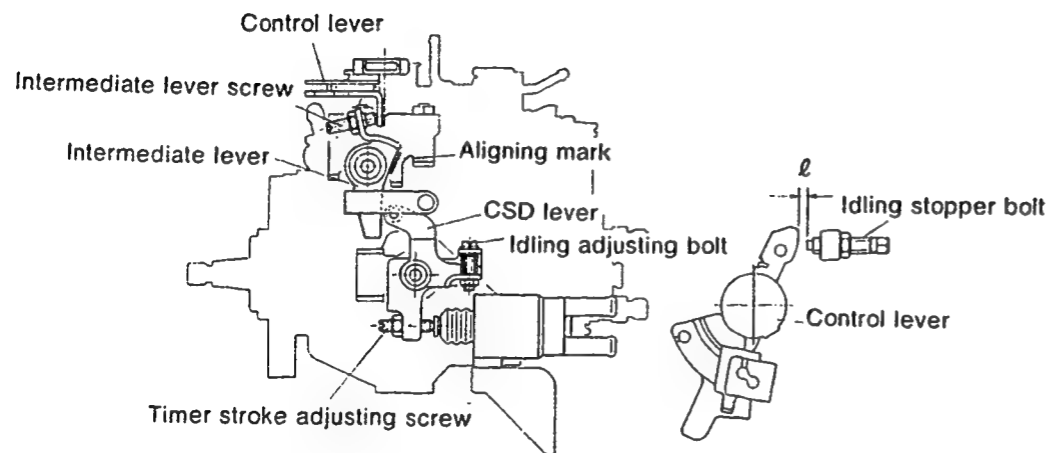

Fig. 1

2) Intermediate lever position adjustment

1. Insert a block gauge (thickness gauge) of 1.0 ± 0.05 mm thickness between the control lever and the idling stopper bolt.
2. Align the intermediate lever with the aligning mark.
3. Adjust the intermediate lever set screw so that the control lever and intermediate lever set screw are in contact, and then fix in position using the locknut.

3) CSD lever adjustment

1. Calculate the block gauge dimension $l \pm 0.05$ mm from Fig. 2 according to the atmospheric temperature at the time of adjustment.
2. Insert the block gauge (thickness gauge) between the control lever and the idling stopper bolt.
3. Using the idling bolt, adjust so that the CSD lever roller and intermediate lever are in contact.

Formula for calculating Fig. 2

Formula for calculating timer stroke:

When $-10 \leq t \leq 20$: $T = -0.0284t + 1.367$

When $20 \leq t \leq 60$: $T = -0.02t + 1.2$

Formula for calculating control lever and idling stopper bolt gap:

When $-10 \leq t \leq 20$: $l = -0.0667t + 3.23$

When $20 \leq t \leq 60$: $l = -0.05t + 2.9$

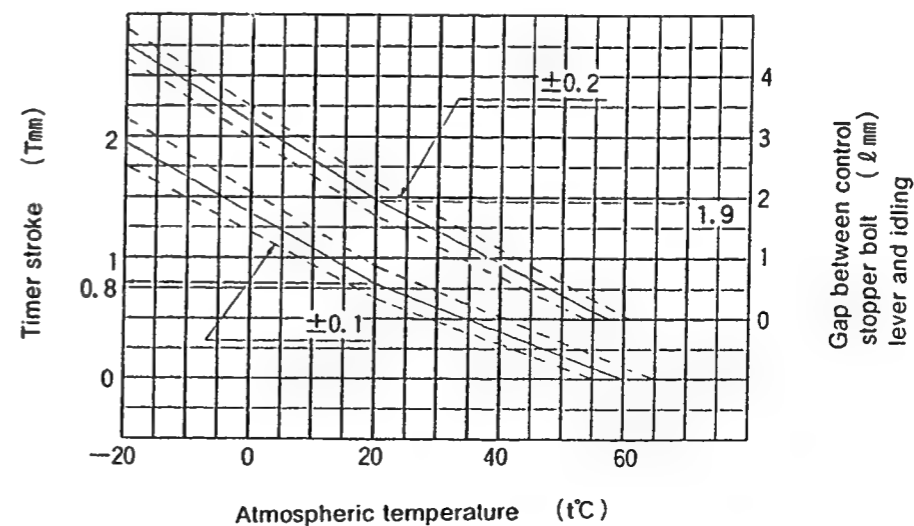

Fig. 2

INJ. PUMP CALIBRATION DATA

Distributor-type

TEST OIL:
ISO 4113 or
SAE J967d

ENGINE MODEL : CD17

BOSCH No.9 460 610 062 ^{1/4}
DKKC No. 104748-2280
Date : 20.Nov.1986 [2]
Company : NISSAN
No. 16700 16A62

Injection pump No: 104648-2160 [NP-VE4/8F2500LNP164]

Pump rotation : Counter clockwise-viewed from drive side

For Test Condition see
Microfiche No.WP-210(N16)

Pre-stroke : - mm

1. Setting	Pump speed (rpm)	Settings	Charge air press(mmHg)	Difference in delivery(cc)
1-1 Timing device travel	1,700	4.5~ 4.9 (mm)		
1-2 Supply pump pressure	1,700	5.6~ 6.2 (kg/cm ²)		
1-3 Full load delivery without charge air pressure	1,000	35.6~36.6 (cc/1,000st)		3.0
Full load delivery with charge air pressure		(cc/1,000st)		
1-4 Idle speed regulation	300	4.3~ 8.3 (cc/1,000st)		2.0
1-5 Start	100	55.0~90.0 (cc/1,000st)		
1-6 Full-load speed regulation	2,300	14.7~20.7 (cc/1,000st)		
1-7 ACS Adjustment	1,000	5.0~ 6.0	-164±5	
1-8				

2. Test Specifications

2-1 Timing device	N = rpm mm	1,200 1.7~ 2.5	1,800 4.0~ 5.2	2,500 6.8~ 8.0
2-2 Supply pump	N = rpm kg/cm ²	1,200 3.0~ 3.8	1,600 4.4~ 5.2	2,500 6.1~ 6.9
2-3 Overflow delivery	N = rpm cc/10s	1,200 36.0~80.0		
2-4 Fuel injection quantities				
Speed control lever position	Pump speed (rpm)	Fuel delivery (cc/1,000st)	Charge air press(mmHg)	Difference in delivery(cc)
Full speed position	1,200	29.0~31.0		
	600	24.8~28.8		
	2,500	26.7~30.7		
	2,700	11.4~18.4		
	2,900	Below 6		
Switch OFF	400	0		
Idling position	400	4.8~ 8.8		
	600	Below 3		
Partial load	700	10.0~20.0		
2-5 Solenoid	Max.cut-in voltage : 8 V Test voltage : 12~14 V			

3. Dimensions

K	3.2~3.4 mm
KF	5.7~5.9 mm
MS	1.5~1.7 mm
BCS	- mm
Control lever angle	
α	21.0~29.0 deg
A	2.5~ 3.0 mm
β	39.0~49.0 deg
B	11.0~16.0 mm
γ	13.5~14.5 deg
C	8.6~ 9.2 mm

Starting Injection Quantity Adjustment

Adjust the starting injection quantity (item 1/5) using the adjusting bolt (as shown in the figure at right) .

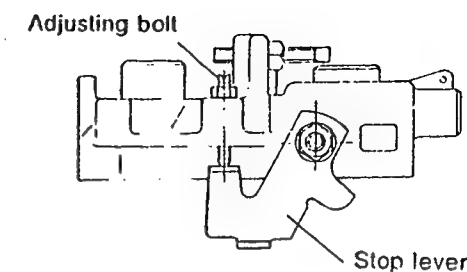

■ W-CSD Adjustment

1) Timer stroke adjustment

1. Calculate the timer stroke from Fig. 2 according to the atmospheric temperature at the time of adjustment.
2. Adjust using timer stroke adjusting screw so that the timer stroke is as calculated in Step 1.

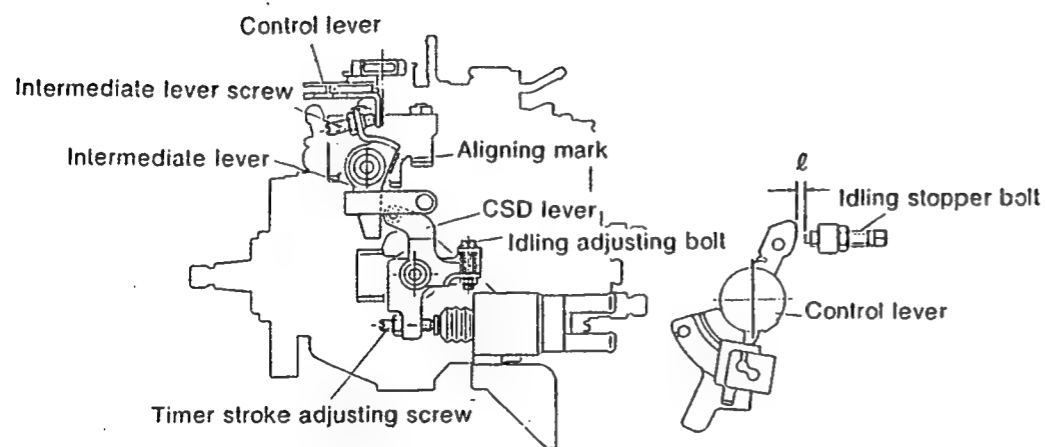

Fig. 1

2) Intermediate lever position adjustment

1. Insert a block gauge (thickness gauge) of 1.0 ± 0.05 mm thickness between the control lever and the idling stopper bolt.
2. Align the intermediate lever with the aligning mark.
3. Adjust the intermediate lever set screw so that the control lever and intermediate lever set screw are in contact, and then fix in position using the locknut.

3) CSD lever adjustment

1. Calculate the block gauge dimension $l \pm 0.05$ mm from Fig. 2 according to the atmospheric temperature at the time of adjustment.
2. Insert the block gauge (thickness gauge) between the control lever and the idling stopper bolt.
3. Using the idling bolt, adjust so that the CSD lever roller and intermediate lever are in contact.

Formula for calculating Fig. 2

Formula for calculating timer stroke:

When $-10 \leq t \leq 20$: $T = -0.0284t + 1.367$

When $20 \leq t \leq 60$: $T = -0.02t + 1.2$

Formula for calculating control lever and idling stopper bolt gap:

When $-10 \leq t \leq 20$: $l = -0.0667t + 3.23$

When $20 \leq t \leq 60$: $l = -0.05t + 2.9$

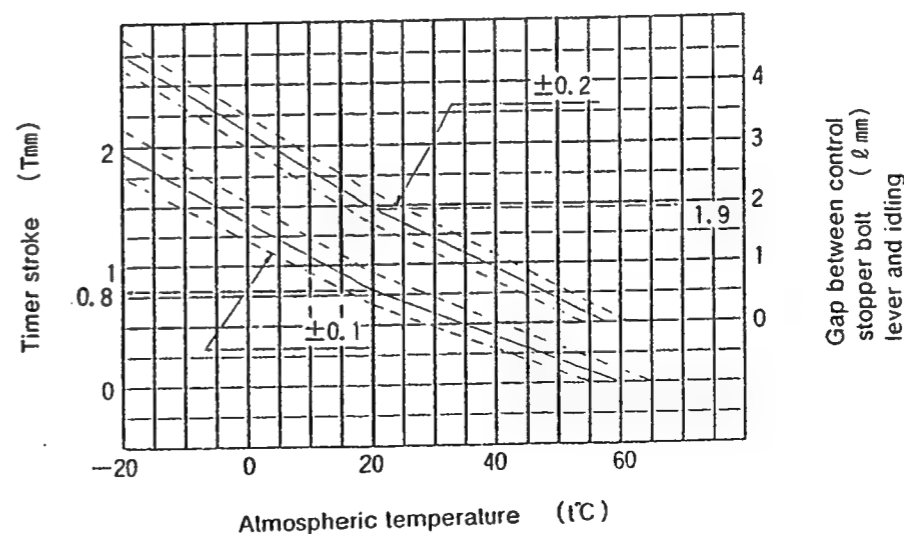

Fig. 2

INJ. PUMP CALIBRATION DATA

Distributor-type

TEST OIL:
I S O 4113 or
S A E J967d

ENGINE MODEL : CD17

Injection pump No: 104648-2160 (NP-VE4/8F2500LNP164)

Pump rotation : Counter clockwise-viewed from drive side

Pre-stroke : - mm

1/4
BOSCH No.9 460 G10 064
DKKC No. 104748-2300
Date : 20.Nov.1986 [2]
Company : NISSAN
No. 16700 16A72

For Test Condition see
Microfiche No.WP-210(N16)

1. Setting	Pump speed (rpm)	Settings	Charge air press(mmHg)	Difference in delivery(cc)
1-1 Timing device travel	1,700	4.5~ 4.9 (mm)		
1-2 Supply pump pressure	1,700	5.6~ 6.2 (kg/cm ²)		
1-3 Full load delivery without charge air pressure	1,000	35.6~36.6 (cc/1,000st)		3.0
Full load delivery with charge air pressure		(cc/1,000st)		
1-4 Idle speed regulation	300	4.3~ 8.3 (cc/1,000st)		2.0
1-5 Start	100	55.0~90.0 (cc/1,000st)		
1-6 Full-load speed regulation	2,300	14.7~20.7 (cc/1,000st)		
1-7 ACS Adjustment	1,000	5.0~ 6.0	-164±5	
1-8				

2. Test Specifications

2-1 Timing device	N = rpm mm	1,200 1.7~ 2.5	1,800 4.0~ 5.2	2,500 6.8~ 8.0
2-2 Supply pump	N = rpm kg/cm ²	1,200 3.0~ 3.8	1,800 4.4~ 5.2	2,500 6.1~ 6.9
2-3 Overflow delivery	N = rpm cc/10s	1,200 36.0~80.0		
2-4 Fuel injection quantities				
Speed control lever position	Pump speed (rpm)	Fuel delivery (cc/1,000st)	Charge air press(mmHg)	Difference in delivery(cc)
Full speed position	1,200	29.0~31.0		
	600	24.8~28.8		
	2,500	26.7~30.7		
	2,700	11.4~18.4		
	2,900	Below 6		
Switch OFF	400	0		
Idling position	400	4.8~ 8.8		
	600	Below 3		
Partial load	700	10.0~20.0		
2-5 Solenoid	Max.cut-in voltage : 8 V Test voltage : 12~14 V			

3. Dimensions

K	3.2~3.4 mm
KF	5.7~5.9 mm
MS	1.5~1.7 mm
BCS	- mm

Control lever angle

α	21.0~29.0 deg
A	2.5~ 8.0 mm
β	39.0~49.0 deg
B	11.0~16.0 mm
γ	13.5~14.5 deg
C	8.6~ 9.2 mm

Starting Injection Quantity Adjustment

Adjust the starting injection quantity (item 1/5) using the adjusting bolt (as shown in the figure at right).

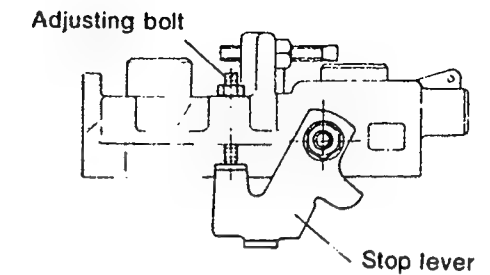

■ W-CSD Adjustment

1) Timer stroke adjustment

1. Calculate the timer stroke from Fig. 2 according to the atmospheric temperature at the time of adjustment.
2. Adjust using timer stroke adjusting screw so that the timer stroke is as calculated in Step 1.

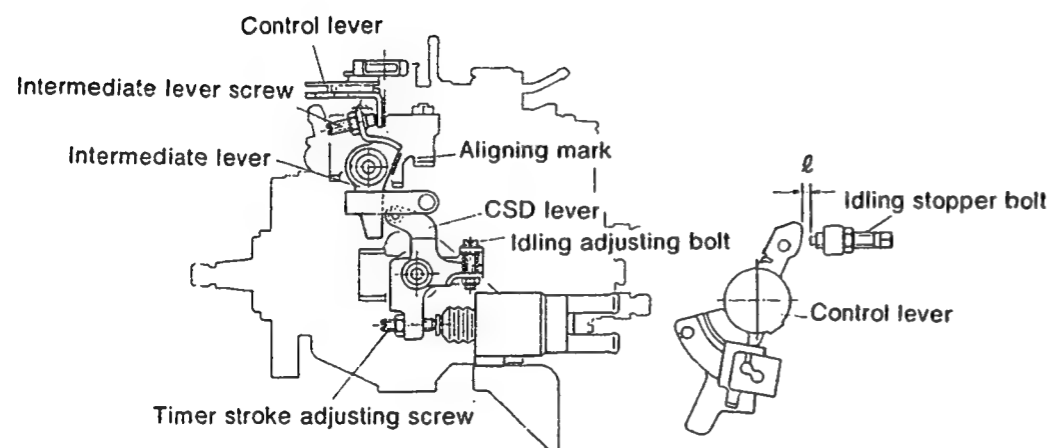

Fig. 1

2) Intermediate lever position adjustment

1. Insert a block gauge (thickness gauge) of 1.0 ± 0.05 mm thickness between the control lever and the idling stopper bolt.
2. Align the intermediate lever with the aligning mark.
3. Adjust the intermediate lever set screw so that the control lever and intermediate lever set screw are in contact, and then fix in position using the locknut.

3) CSD lever adjustment

1. Calculate the block gauge dimension $l \pm 0.05$ mm from Fig. 2 according to the atmospheric temperature at the time of adjustment.
2. Insert the block gauge (thickness gauge) between the control lever and the idling stopper bolt.
3. Using the idling bolt, adjust so that the CSD lever roller and intermediate lever are in contact.

Formula for calculating Fig. 2

Formula for calculating timer stroke:

When $-10 \leq t \leq 20$: $T = -0.0284t + 1.367$

When $20 \leq t \leq 60$: $T = -0.02t + 1.2$

Formula for calculating control lever and idling stopper bolt gap:

When $-10 \leq t \leq 20$: $l = -0.0667t + 3.23$

When $20 \leq t \leq 60$: $l = -0.05t + 2.9$

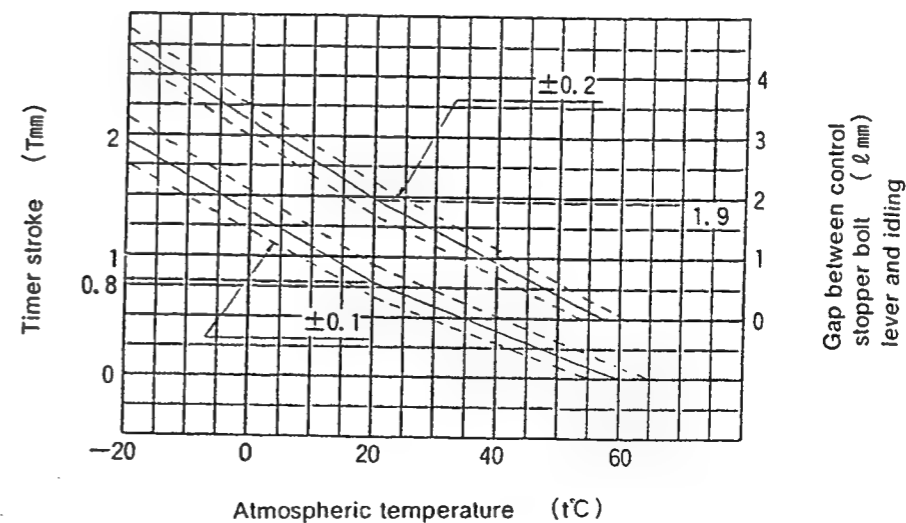

Fig. 2

INJ. PUMP CALIBRATION DATA

Distributor-type

TEST OIL:
I S O 4113 or
S A E J967d

ENGINE MODEL : CD17

1/4
BOSCH No.9 460 610 066
DKKC No. 104748-2370
Date : 20.Nov.1986 [1]
Company : NISSAN
No. 16700 16A63

Injection pump No: 104648-2180 [NP-VE4/8F2500LNF164]

Pump rotation : Counter clockwise-viewed from drive side

For Test Condition see
Microfiche No.WP-210(N16)

Pre-stroke : - mm

1. Setting	Pump speed (rpm)	Settings	Charge air press(mmHg)	Difference in delivery(cc)
1-1 Timing device travel	1,200	1.8~ 2.4 (mm)		2.5
1-2 Supply pump pressure	1,200	3.1~ 3.7 (kg/cm ²)		
1-3 Full load delivery without charge air pressure	1,200	29.5~30.5 (cc/1,000st)		
		Full load delivery with charge air pressure (cc/1,000st)		
1-4 Idle speed regulation	400	5.3~ 8.3 (cc/1,000st)		
1-5 Start	100	45.3~55.3 (cc/1,000st)		
1-6 Full-load speed regulation	2,700	11.9~17.9 (cc/1,000st)		
1-7				
1-8				

2. Test Specifications

2-1 Timing device	N = rpm	1,200	1,800	2,500
	mm	1.7~ 2.5	4.0~ 5.2	6.8~ 8.0
2-2 Supply pump	N = rpm	1,200	1,800	2,500
	kg/cm ²	3.0~ 3.8	4.4~ 5.2	6.1~ 6.9
2-3 Overflow delivery	N = rpm	1,200		
	cc/10s	36.0~80.0		

2-4 Fuel injection quantities

Speed control lever position	Pump speed (rpm)	Fuel delivery (cc/1,000st)	Charge air press(mmHg)	Difference in delivery(cc)
Full speed position	1,200	29.0~31.0		
	600	24.8~28.8		
	2,500	26.7~30.7		
	2,700	11.4~18.4		
	2,900	Below 6		
Switch OFF	400	0		
Idling position	400	4.8~8.8		2.5
	600	Below 3		
Partial load	700	10.0~20.0		
2-5 Solenoid	Max.cut-in voltage : 8 V Test voltage : 12~14 V			

3. Dimensions

K	3.2~3.4	mm
KF	5.7~5.9	mm
MS	1.5~1.7	mm
BCS		mm
Control lever angle		
α	1~-1	deg
A	15.4~18.1	mm
β	39.0~49.0	deg
B	11.0~16.0	mm
γ	13.5~14.5	deg
C	8.6~ 9.2	mm

Control Lever Angle Measurement Position

① Measure the control lever angles (α, β, γ) at hole A.

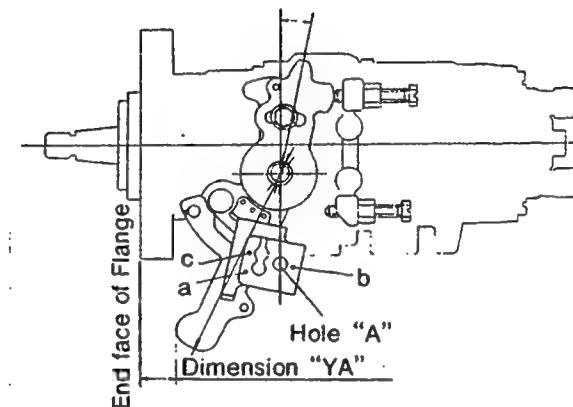

Starting Injection Quantity Adjustment

Adjust the starting injection quantity (item 1/5) using the adjusting bolt (as shown in the figure at right).

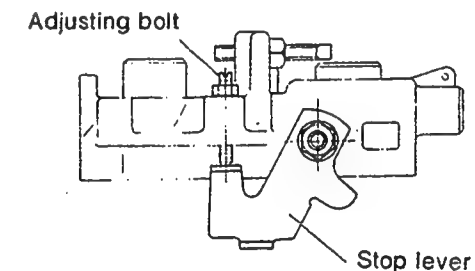

■ W-CSD Adjustment

1) Timer stroke adjustment

1. Calculate the timer stroke from Fig. 2 according to the atmospheric temperature at the time of adjustment.
2. Adjust using timer stroke adjusting screw so that the timer stroke is as calculated in Step 1.

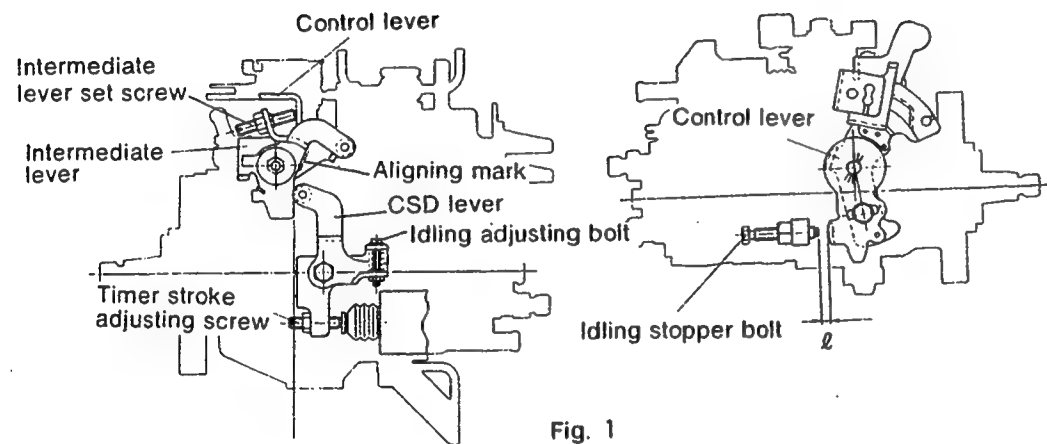

Fig. 1

2) Intermediate lever position adjustment

1. Insert a block gauge (thickness gauge) of 1.9 ± 0.05 mm thickness between the control lever and the idling stopper bolt.
2. Align the intermediate lever with the aligning mark.
3. Adjust the intermediate lever set screw so that the control lever and intermediate lever set screw are in contact, and then fix in position using the locknut.

3) CSD lever adjustment

1. Calculate the block gauge dimension $l \pm 0.05$ mm from Fig. 2 according to the atmospheric temperature at the time of adjustment.
2. Insert the block gauge (thickness gauge) between the control lever and the idling stopper bolt.
3. Using the idling bolt, adjust so that the CSD lever roller and intermediate lever are in contact.

Formula for calculating Fig. 2

Formula for calculating timer stroke:

When $-10 \leq t \leq 20$: $T = -0.0367t + 1.284$

When $20 \leq t \leq 40$: $T = -0.0275t + 1.1$

Formula for calculating control lever and idling stopper bolt gap:

When $-10 \leq t \leq 20$: $l = -0.0275t + 3.63$

When $20 \leq t \leq 40$: $l = -0.075t + 3.4$

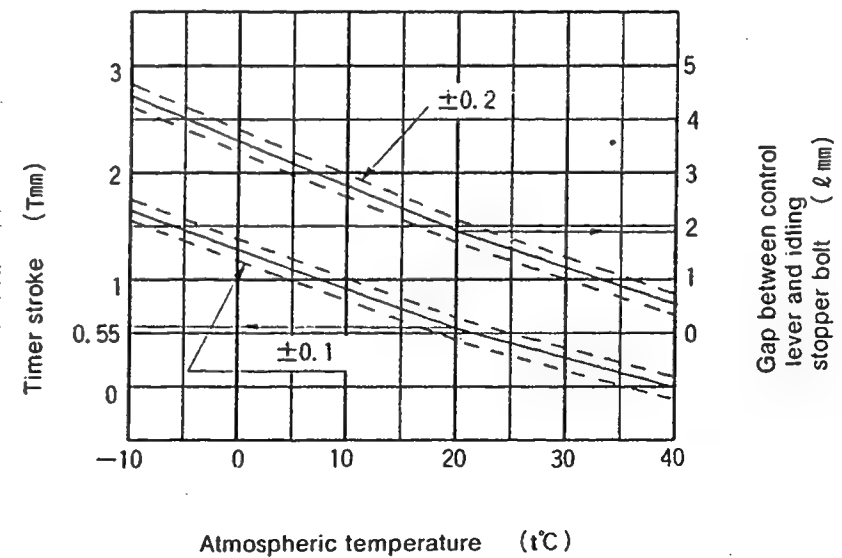

Fig. 2

INJ. PUMP CALIBRATION DATA

Distributor-type

TEST OIL:
ISO 4113 or
SAE J967d

ENGINE MODEL : CD17

Injection pump No: 104648-2180 (NP-VE4/8F2500LNP164)

Pump rotation : Counter clockwise-viewed from drive side

Pre-stroke : - mm

BOSCH No.9 460 610 068

DKKC No. 104748-2390

Date : 20.Nov.1986 ①

Company : NISSAN

No. 16700 16A73

For Test Condition see
Microfiche No.WP-210(N16)

1. Setting	Pump speed (rpm)	Settings	Charge air press(mmHg)	Difference in delivery(cc)
1-1 Timing device travel	1,200	1.8~ 2.4 (mm)		2.5
1-2 Supply pump pressure	1,200	3.1~ 3.7 (kg/cm ²)		
1-3 Full load delivery without charge air pressure	1,200	29.5~30.5 (cc/1,000st)		
		(cc/1,000st)		
1-4 Idle speed regulation	400	5.3~ 8.3 (cc/1,000st)		
1-5 Start	100	45.3~55.3 (cc/1,000st)		
1-6 Full-load speed regulation	2,700	11.9~17.9 (cc/1,000st)		
1-7				
1-8				

2. Test Specifications

2-1 Timing device	N = rpm	1,200	1,800	2,500
	mm	1.7~ 2.5	4.0~ 5.2	6.8~ 8.0
2-2 Supply pump	N = rpm	1,200	1,800	2,500
	kg/cm ²	3.0~ 3.8	4.4~ 5.2	6.1~ 6.9
2-3 Overflow delivery	N = rpm	1,200		
	cc/10s	36.0~80.0		
2-4 Fuel injection quantities				
Speed control lever position	Pump speed (rpm)	Fuel delivery (cc/1,000st)	Charge air press(mmHg)	Difference in delivery(cc)
Full speed position	1,200	29.0~31.0		
	600	24.8~28.8		
	2,500	26.7~30.7		
	2,700	11.4~18.4		
	2,900	Below 6		
Switch OFF	400	0		
Idling position	400	4.8~8.8		2.5
	600	Below 3		
Partial load	700	10.0~20.0		
2-5 Solenoid	Max.cut-in voltage : 8 V Test voltage : 12~14 V			

3. Dimensions

K	3.2~3.4	mm
KF	5.7~5.9	mm
MS	1.5~1.7	mm
BCS		mm

Control lever angle

α	1~-1	deg
A	15.4~18.1	mm
β	39.0~49.0	deg
B	11.0~16.0	mm
γ	13.5~14.5	deg
C	8.6~ 9.2	mm

Control Lever Angle Measurement Position

① Measure the control lever angles (α, β, γ) at hole A.

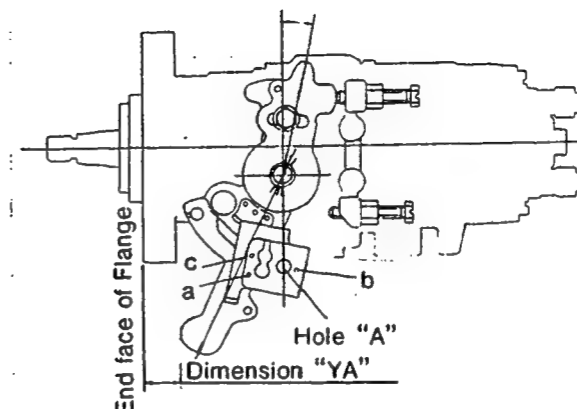

Starting Injection Quantity Adjustment

Adjust the starting injection quantity (item 1/5) using the adjusting bolt (as shown in the figure at right).

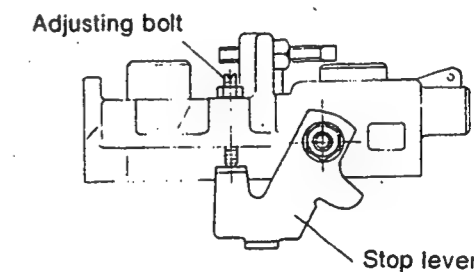

■ W-CSD Adjustment

1) Timer stroke adjustment

1. Calculate the timer stroke from Fig. 2 according to the atmospheric temperature at the time of adjustment.
2. Adjust using timer stroke adjusting screw so that the timer stroke is as calculated in Step 1.

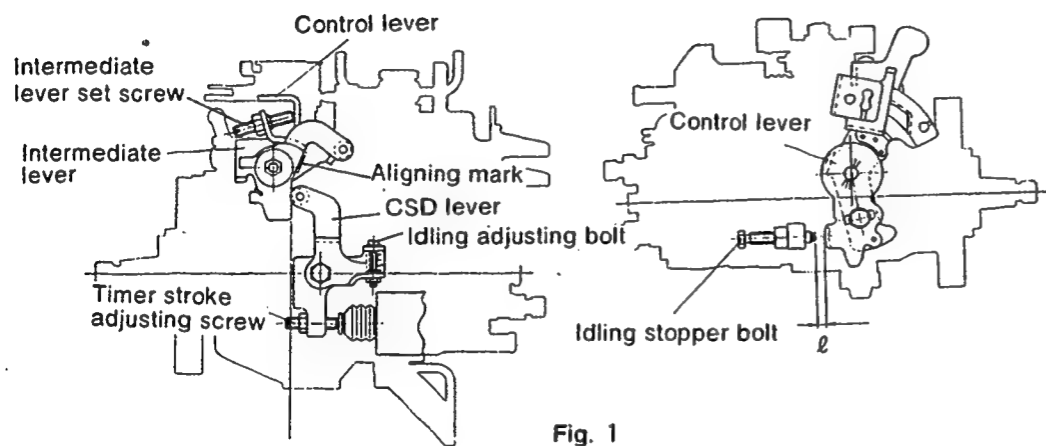

Fig. 1

2) Intermediate lever position adjustment

1. Insert a block gauge (thickness gauge) of 1.9 ± 0.05 mm thickness between the control lever and the idling stopper bolt.
2. Align the intermediate lever with the aligning mark.
3. Adjust the intermediate lever set screw so that the control lever and intermediate lever set screw are in contact, and then fix in position using the locknut.

3) CSD lever adjustment

1. Calculate the block gauge dimension $l \pm 0.05$ mm from Fig. 2 according to the atmospheric temperature at the time of adjustment.
2. Insert the block gauge (thickness gauge) between the control lever and the idling stopper bolt.
3. Using the idling bolt, adjust so that the CSD lever roller and intermediate lever are in contact.

Formula for calculating Fig. 2

Formula for calculating timer stroke:

When $-10 \leq t \leq 20$: $T = -0.0367t + 1.284$

When $20 \leq t \leq 40$: $T = -0.0275t + 1.1$

Formula for calculating control lever and idling stopper bolt gap:

When $-10 \leq t \leq 20$: $l = -0.0275t + 3.63$

When $20 \leq t \leq 40$: $l = -0.075t + 3.4$

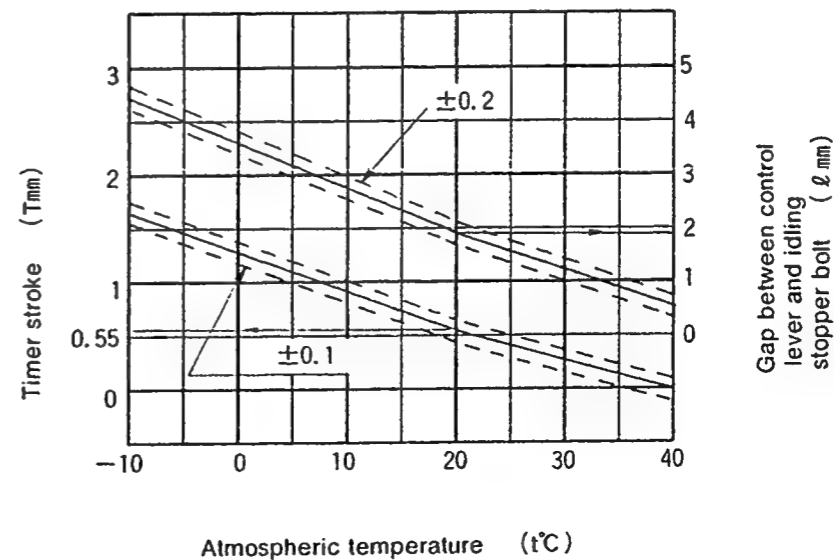

Fig. 2

L - 13

INJ. PUMP CALIBRATION DATA

Distributor-type

TEST OIL:
ISO 4113 or
SAE J967d

ENGINE MODEL : 4FD1

BOSCH No.9 460 610 113

DKKC No. 104749-1490

Date : 20.Nov.1986 0

Company : ISUZU

No. 8941240060

Injection pump No: 104649-1350 (NP-VE4/9F2250RNP220)

Pump rotation : clockwise-viewed from drive side

For Test Condition see
Microfiche No.WP-210(N16)

Pre-stroke : 0.23~0.27 mm

1. Setting	Pump speed (rpm)	Settings	Charge air press(mmHg)	Difference in delivery(cc)
1-1 Timing device travel	1,250	3.4~ 3.8 (mm)		
1-2 Supply pump pressure	1,250	4.6~ 5.0 (kg/cm ²)		
1-3 Full load delivery without charge air pressure	1,250	37.2~38.2 (cc/1,000st)		3
Full load delivery with charge air pressure		(cc/1,000st)		
1-4 Idle speed regulation	340	5.5~ 9.5 (cc/1,000st)		2
1-5 Start	100	50.0~70.0 (cc/1,000st)		
1-6 Full-load speed regulation	2,600	15.1~17.1 (cc/1,000st)		4.5
1-7				
1-8				

2. Test Specifications

2-1 Timing device	N = rpm	1,250 3.3~ 3.9	2,000 6.3~ 7.5	2,500 8.6~ 9.4
2-2 Supply pump	N = rpm kg/cm ²	1,250 4.6~ 5.0	2,000 6.2~ 6.8	
2-3 Overflow delivery	N = rpm cc/10s	1,250 55.0~98.0		
2-4 Fuel injection quantities				
Speed control lever position	Pump speed (rpm)	Fuel delivery (cc/1,000st)	Charge air press(mmHg)	Difference in delivery(cc)
Full speed position	1,250	36.7~38.7		
	600	31.2~35.2		
	1,800	34.2~38.2		
	2,250	33.2~37.2		
	2,600	14.6~17.6		
	2,900	Below 4.5		
Switch OFF	340	0		
Idling position	340	5.5~ 9.5		
	500	0		
2-5 Solenoid	Max.cut-in voltage : 8 V Test voltage : 12~14 V			

3. Dimensions

K	3.2~3.4	mm
KF	5.7~5.9	mm
MS	1.5~1.7	mm
BCS	-	mm

Control lever angle

α	-7~+1	deg
A	8.8~11.4	mm
β	32.0~42.0	deg
B	10.2~13.5	mm
γ	-	deg
C	-	mm



DIESEL KIKI CO., LTD.
Service Department

3-6-7 SHIBUYA, SHIBUYA-KU, TOKYO 150, JAPAN
Tel (03) 400-1551 · Fax: (03) 499-4115

INJ. PUMP CALIBRATION DATA

Distributor-type

BOSCH No.9 460 610 114
 DKKC No. 104749-1500
 Date: 20.Nov.1986
 Company: ISUZU
 No. 894124 8420

104749-1500

TEST OIL:
 I S O 4113 or
 S A E J967d

ENGINE MODEL : C223

Injection pump No: 104649-1360 [NP-VE4/9F2175RNP223]

Pump rotation : clockwise-viewed from drive side

For Test Condition see
 Microfiche No.WP-210(N16)

Pre-stroke : - mm

1. Setting	Pump speed (rpm)	Settings	Charge air press(mmHg)	Difference in delivery(cc)
1-1 Timing device travel	1,500	4.2~ 4.6 (mm)		
1-2 Supply pump pressure	1,500	5.2~ 5.6 (kg/cm ²)		
1-3 Full load delivery without charge air pressure	1,250	35.8~36.8 (cc/1,000st)		3
Full load delivery with charge air pressure		(cc/1,000st)		
1-4 Idle speed regulation	375	5.6~ 9.6 (cc/1,000st)		2
1-5 Start	100	Above 63 (cc/1,000st)		
1-6 Full-load speed regulation	2,550	7.8~13.8 (cc/1,000st)		3
1-7 CSD Adjustment	500~700	Release speed		
1-8				

2. Test Specifications

2-1 Timing device	N = rpm	1,000	1,500	2,175
	mm	1.6~ 2.8	4.1~ 4.7	7.0~ 7.8
2-2 Supply pump	N = rpm	1,000	1,500	2,175
	kg/cm ²	3.8~ 4.4	5.2~ 5.6	6.6~ 7.2
2-3 Overflow delivery	N = rpm	1,000		
	cc/10s	48.0~92.0		
2-4 Fuel injection quantities				
Speed control lever position	Pump speed (rpm)	Fuel delivery (cc/1,000st)	Charge air press(mmHg)	Difference in delivery(cc)
Full speed position	1,250	35.3~37.3		
	600	29.7~33.7		
	2,175	32.0~36.2		
	2,550	7.3~14.3		
	2,700	Below 3.5		
Switch OFF	375	0		
Idling position	375	5.6~9.6		
	500	Below 3		
2-5 Solenoid	Max.cut-in voltage : 8 V Test voltage : 12~14 V			

3. Dimensions

K	3.2~3.4 mm
KF	5.7~5.9 mm
MS	1.7~1.9 mm
BCS	- mm

Control lever angle

α	21.0~29.0 deg
A	9.6~12.2 mm
β	37.0~47.0 deg
B	11.9~15.1 mm
γ	- deg
C	- mm

■ CSD Adjustment

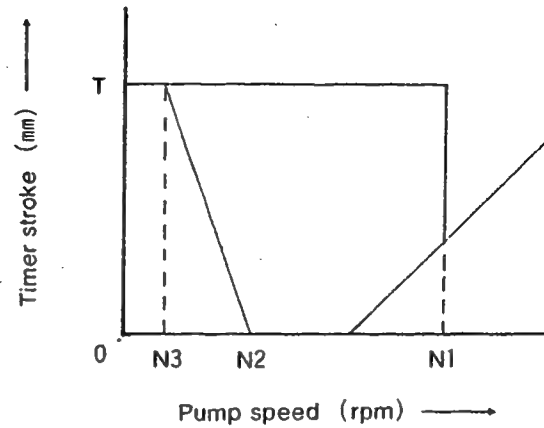

Standard values

N1 (Release speed)	500~700rpm
N2	Less than 225rpm
T	2.7~3.1mm

1) Bleed of air

1. Run the engine at N1 or above.
2. Gradually decrease the pump speed and check the 0 point of the measuring device.
3. Run the pump at a speed midway between N2 and N3.
4. Check that the test oil flows from the CSD overflow.

2) Adjustment

1. Check that the timer stroke is T when the pump is stopped.
2. Adjust the shim thickness so that at the CSD release point the timer piston begins moving in the timer stroke decrease direction at a pump speed of 600±100 rpm.
3. Gradually decrease the pump speed, and check that the CSD begins to operate at speeds less than N2.

Note :

When measuring the release speed, check that there is no leakage from the CSD overflow.

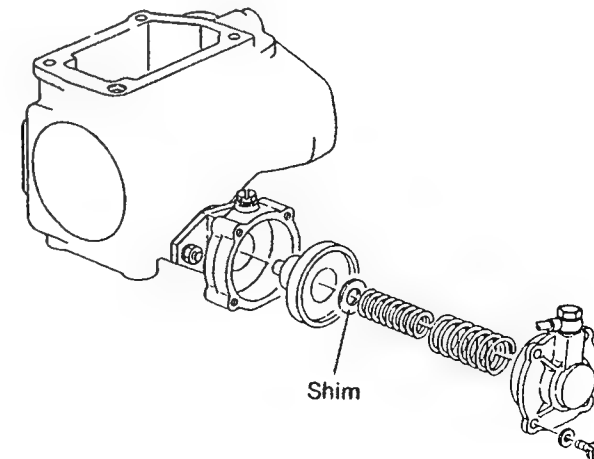

INJ. PUMP CALIBRATION DATA Distributor-type

TEST OIL:
I S O 4113 or
S A E J967d

ENGINE MODEL : C223

BOSCH No.9 460 610 116

DKKC No. 104749-1520

Date : 20.Nov.1986 0

Company : ISUZU

No. 894124 8440

104749-1520

Injection pump No: 104649-1360 [NP-VE4/9F2175RNP223]

Pump rotation : clockwise-viewed from drive side

For Test Condition see
Microfiche No.WP-210(N16)

Pre-stroke : - mm

1. Setting	Pump speed (rpm)	Settings	Charge air press(mmHg)	Difference in delivery(cc)
1-1 Timing device travel	1,500	4.2~ 4.6 (mm)		
1-2 Supply pump pressure	1,500	5.2~ 5.6 (kg/cm ²)		
1-3 Full load delivery without charge air pressure	1,250	35.8~36.8 (cc/1,000st)		3
Full load delivery with charge air pressure		(cc/1,000st)		
1-4 Idle speed regulation	375	5.6~ 9.6 (cc/1,000st)		2
1-5 Start	100	Above 63 (cc/1,000st)		
1-6 Full-load speed regulation	2,550	7.8~13.8 (cc/1,000st)		3
1-7 CSD Adjustment	500~700	Release speed		
1-8				

2. Test Specifications

2-1 Timing device	N = rpm	1,000	1,500	2,175
	mm	1.6~ 2.8	4.1~ 4.7	7.0~ 7.8
2-2 Supply pump	N = rpm	1,000	1,500	2,175
	kg/cm ²	3.8~ 4.4	5.2~ 5.6	6.6~ 7.2
2-3 Overflow delivery	N = rpm	1,000		
	cc/10s	48.0~92.0		

2-4 Fuel injection quantities

Speed control lever position	Pump speed (rpm)	Fuel delivery (cc/1,000st)	Charge air press(mmHg)	Difference in delivery(cc)
Full speed position	1,250	35.3~37.3		
	600	29.7~33.7		
	2,175	32.0~36.2		
	2,550	7.3~14.3		
	2,700	Below 3.5		
Switch OFF	375	0		
Idling position	375	5.6~9.6		
	500	Below 3		
2-5 Solenoid	Max.cut-in voltage : 8 V Test voltage : 12~14 V			

3. Dimensions

K	3.2~3.4	mm
KF	5.7~5.9	mm
MS	1.7~1.9	mm
BCS	-	mm

Control lever angle

α	21.0~29.0	deg
A	9.6~12.2	mm
β	37.0~47.0	deg
B	11.9~15.1	mm
γ	-	deg
C	-	mm

■ CSD Adjustment

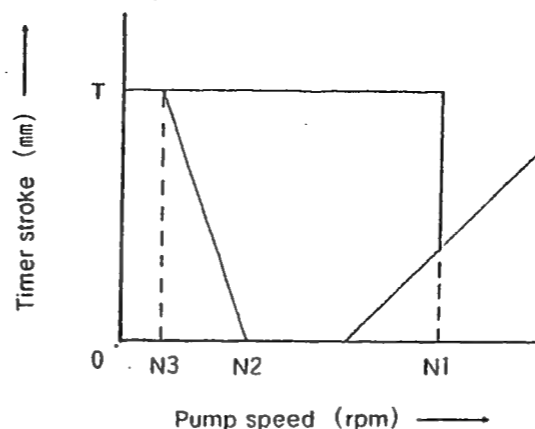

Standard values

N1 (Release speed) 500~700rpm

N2 Less than 225rpm

T 2.7~3.1mm

1) Bleed of air

1. Run the engine at N1 or above.
2. Gradually decrease the pump speed and check the 0 point of the measuring device.
3. Run the pump at a speed midway between N2 and N3.
4. Check that the test oil flows from the CSD overflow.

2) Adjustment

1. Check that the timer stroke is T when the pump is stopped.
2. Adjust the shim thickness so that at the CSD release point the timer piston begins moving in the timer stroke decrease direction at a pump speed of 600±100 rpm.
3. Gradually decrease the pump speed, and check that the CSD begins to operate at speeds less than N2.

Note :

When measuring the release speed, check that there is no leakage from the CSD overflow.

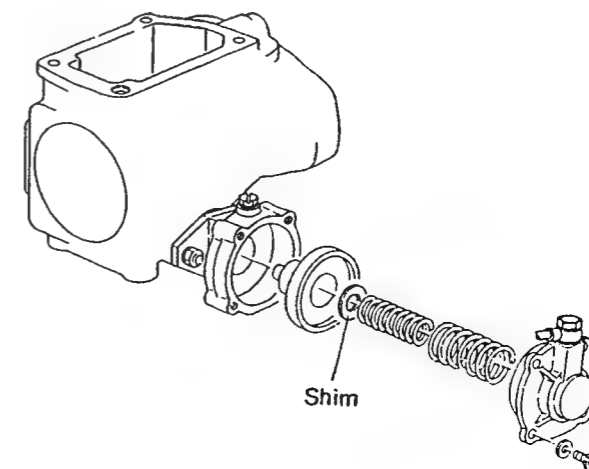

INJ. PUMP CALIBRATION DATA Distributor-type

TEST OIL:
I S O 4113 or
S A E J967d

ENGINE MODEL : C223

BOSCH No. 9 460 610 117
DKKC No. 104749-1530
Date : 20.Nov.1986 0
Company : ISUZU
No. 894124 8450

104749-1530

Injection pump No: 104649-1360 (NP-VE4/9F2175RNP223)

Pump rotation : clockwise-viewed from drive side

For Test Condition see
Microfiche No.WP-210(N16)

Pre-stroke : - mm

1. Setting	Pump speed (rpm)	Settings	Charge air press(mmHg)	Difference in delivery(cc)
1-1 Timing device travel	1,500	4.2~ 4.6 (mm)		
1-2 Supply pump pressure	1,500	5.2~ 5.6 (kg/cm ²)		
1-3 Full load delivery without charge air pressure	1,250	35.8~36.8 (cc/1,000st)		3
Full load delivery with charge air pressure		(cc/1,000st)		
1-4 Idle speed regulation	375	5.6~ 9.6 (cc/1,000st)		2
1-5 Start	100	Above 63 (cc/1,000st)		
1-6 Full-load speed regulation	2,550	7.8~13.8 (cc/1,000st)		3
1-7 CSD Adjustment	500~700	Release speed		
1-8				

2. Test Specifications

2-1 Timing device	N = rpm	mm	1,000	1,500	2,175
			1.6~ 2.8	4.1~ 4.7	7.0~ 7.8
2-2 Supply pump	N = rpm	kg/cm ²	1,000	1,500	2,175
			3.8~ 4.4	5.2~ 5.6	6.6~ 7.2
2-3 Overflow delivery	N = rpm	cc/10s	1,000		
			48.0~92.0		
2-4 Fuel injection quantities					
Speed control lever position	Pump speed (rpm)	Fuel delivery (cc/1,000st)	Charge air press(mmHg)	Difference in delivery(cc)	
Full speed position	1,250	35.3~37.3			
	600	29.7~33.7			
	2,175	32.0~36.2			
	2,550	7.3~14.3			
	2,700	Below 3.5			
Switch OFF	375	0			
Idling position	375	5.6~9.6			
	500	Below 3			
2-5 Solenoid	Max.cut-in voltage : 8 V Test voltage : 12~14 V				

3. Dimensions

K	3.2~3.4	mm
KF	5.7~5.9	mm
MS	1.7~1.9	mm
BCS	-	mm

Control lever angle

α	21.0~29.0	deg
A	9.6~12.2	mm
β	37.0~47.0	deg
B	11.9~15.1	mm
γ	-	deg
C	-	mm

■ CSD Adjustment

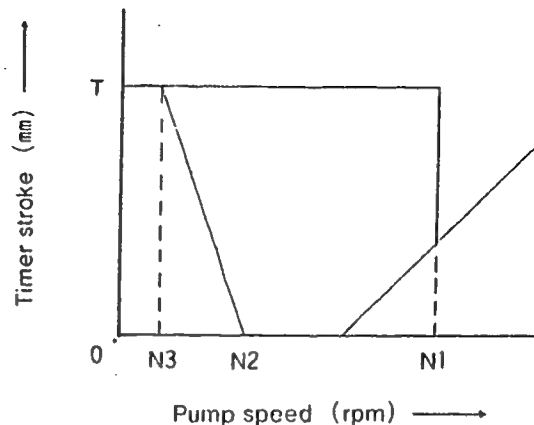

Standard values

N1 (Release speed) 500~700rpm
N2 Less than 225rpm
T 2.7~3.1mm

1) Bleed of air

1. Run the engine at N1 or above.
2. Gradually decrease the pump speed and check the 0 point of the measuring device.
3. Run the pump at a speed midway between N2 and N3.
4. Check that the test oil flows from the CSD overflow.

2) Adjustment

1. Check that the timer stroke is T when the pump is stopped.
2. Adjust the shim thickness so that at the CSD release point the timer piston begins moving in the timer stroke decrease direction at a pump speed of 600±100 rpm.
3. Gradually decrease the pump speed, and check that the CSD begins to operate at speeds less than N2.

Note :

When measuring the release speed, check that there is no leakage from the CSD overflow.

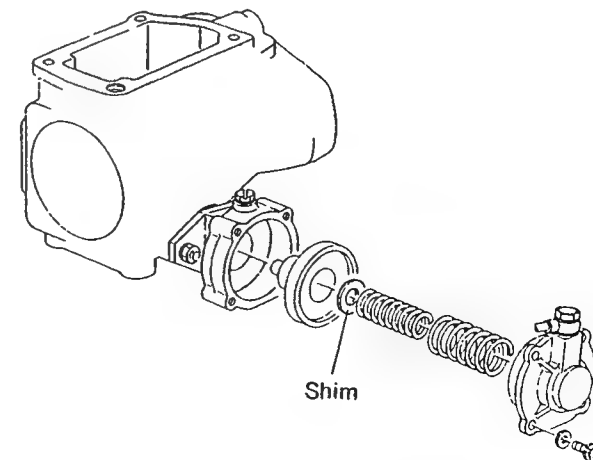

INJ. PUMP CALIBRATION DATA Distributor-type

TEST OIL:
I S O 4113 or
S A E J967d

ENGINE MODEL : C223

Injection pump No: 104649-1390 [NP-VE4/9F2175LNP226]

Pump rotation : Counter clockwise-viewed from drive side

Pre-stroke : — mm

BOSCH No.9 460 610 179

DKKC No. 104749-1600

Date : 20.Nov.1986 0

Company : ISUZU

No. 894127 4730

For Test Condition see
Microfiche No.WP-210(N16)

1. Setting	Pump speed (rpm)	Settings	Charge air press(mmHg)	Difference in delivery(cc)
1-1 Timing device travel	1,500	3.8~ 4.2 (mm)		3.0
1-2 Supply pump pressure	1,500	5.2~ 5.6 (kg/cm ²)		
1-3 Full load delivery without charge air pressure	1,500	37.9~38.9 (cc/1,000st)		
		(cc/1,000st)		
1-4 Idle speed regulation	350	5.5~ 9.5 (cc/1,000st)		2.0
1-5 Start	100	Above 63 (cc/1,000st)		
1-6 Full-load speed regulation	2,440	10.4~16.4 (cc/1,000st)		
1-7				
1-8				

2. Test Specifications

2-1 Timing device	N = rpm mm	1,000 1.4~ 2.6	1,500 3.7~ 4.3	2,175 6.1~ 7.0
2-2 Supply pump	N = rpm kg/cm ²	1,000 3.8~ 4.4	1,500 5.2~ 5.6	2,175 6.6~ 7.2
2-3 Overflow delivery	N = rpm cc/10s	1,000 52.0~95.0		

2-4 Fuel injection quantities				
Speed control lever position	Pump speed (rpm)	Fuel delivery (cc/1,000st)	Charge air press(mmHg)	Difference in delivery(cc)
Full speed position	1,500	37.4~39.4		
	600	28.4~32.4		
	2,175	33.3~37.5		
	2,440	10.4~16.4		
	2,550	Below 6.0		
Switch OFF	350	0		
Idling position	350	5.5~ 9.5		
	450	Below 3.0		

2-5 Solenoid Max.cut-in voltage : 8 V
Test voltage : 12~14 V

3. Dimensions

K	3.2~3.4 mm
KF	5.7~5.9 mm
MS	1.7~1.9 mm
BCS	— mm

Control lever angle

α	21.0~29.0 deg
A	9.6~12.2 mm
β	36.5~46.5 deg
B	11.8~14.9 mm
Y	— deg
C	— mm

INJ. PUMP CALIBRATION DATA Distributor-type

TEST OIL:
I S O 4113 or
S A E J967d

ENGINE MODEL : LD20

Injection pump No: 104649-2000 [NP-VE4/9F2500RNP20]

Pump rotation : clockwise-viewed from drive side

Pre-stroke : — mm

BOSCH No.9 460 610 070

DKKC No. 104749-2000

Date : 20.Nov.1986 3

Company : NISSAN

No. 16700 W1700

For Test Condition see
Microfiche No.WP-210(N16)

1. Setting	Pump speed (rpm)	Settings	Charge air press(mmHg)	Difference in delivery(cc)
1-1 Timing device travel	900	1.1~ 1.7 (mm)		2.5
1-2 Supply pump pressure	900	2.9~ 3.5 (kg/cm ²)		
1-3 Full load delivery without charge air pressure	900	32.5~33.5 (cc/1,000st)		
		(cc/1,000st)		
1-4 Idle speed regulation	325	6.7~ 9.7 (cc/1,000st)		3.0
1-5 Start	100	Above 52 (cc/1,000st)		
1-6 Full-load speed regulation	2,700	7.2~13.2 (cc/1,000st)		
1-7				
1-8				

2. Test Specifications

2-1 Timing device	N = rpm mm	900 1.0~ 1.8	1,800 4.5~ 5.7	2,300 6.9~ 7.8
2-2 Supply pump	N = rpm kg/cm ²	900 2.8~ 3.6	1,800 4.9~ 5.7	2,300 6.2~ 7.0
2-3 Overflow delivery	N = rpm cc/10s	1,000 36.0~80.0		

2-4 Fuel injection quantities				
Speed control lever position	Pump speed (rpm)	Fuel delivery (cc/1,000st)	Charge air press(mmHg)	Difference in delivery(cc)
Full speed position	900	32.0~34.0		
	600	31.2~35.2		
	2,300	30.6~34.6		
	2,700	6.7~13.7		
	2,800	Below 6		
Switch OFF	325	0		
Idling position	325	6.2~10.2		
	500	Below 4		
Partial load	900	5.0~15.0		

2-5 Solenoid Max.cut-in voltage : 8 V
Test voltage : 12~14 V

3. Dimensions

K	3.2~3.4 mm
KF	5.7~5.9 mm
MS	1.1~1.3 mm
BCS	— mm

Control lever angle

α	21.0~29.0 deg
A	— mm
β	36.0~46.0 deg
B	— mm
Y	10.5~11.5 deg
C	— mm

INJ. PUMP CALIBRATION DATA Distributor-type

TEST OIL:
I S O 4113 or
S A E J967d

ENGINE MODEL : LD20

Injection pump No: 104649-2001 [NP-VE4/9F2500RNP20]

Pump rotation : clockwise-viewed from drive side

Pre-stroke : - mm

BOSCH No.9 460 610 071
DKKC No. 104749-2001
Date : 20.Nov.1986 [3]
Company : NISSAN
No. 16700 W1701

For Test Condition see
Microfiche No.WP-210(N16)

1. Setting	Pump speed (rpm)	Settings	Charge air press(mmHg)	Difference in delivery(cc)
1-1 Timing device travel	900	1.1~ 1.7 (mm)		2.5
1-2 Supply pump pressure	900	2.9~ 3.5 (kg/cm ²)		
1-3 Full load delivery without charge air pressure	900	32.5~33.5 (cc/1,000st)		
		(cc/1,000st)		
1-4 Idle speed regulation	325	6.7~ 9.7 (cc/1,000st)		3.0
1-5 Start	100	Above 52 (cc/1,000st)		
1-6 Full-load speed regulation	2,700	7.2~13.2 (cc/1,000st)		
1-7				
1-8				

2. Test Specifications

2-1 Timing device	N = rpm mm	900 1.0~ 1.8	1,800 4.5~ 5.7	2,300 6.9~ 7.8
2-2 Supply pump	N = rpm kg/cm ²	900 2.8~ 3.6	1,800 4.9~ 5.7	2,300 6.2~ 7.0
2-3 Overflow delivery	N = rpm cc/10s	1,000 36.0~80.0		

2-4 Fuel injection quantities

Speed control lever position	Pump speed (rpm)	Fuel delivery (cc/1,000st)	Charge air press(mmHg)	Difference in delivery(cc)
Full speed position	900	32.0~34.0		
	600	31.2~35.2		
	2,300	30.6~34.6		
	2,700	6.7~13.7		
	2,800	Below 6		
Switch OFF	325	0		
Idling position	325	6.2~10.2		
	500	Below 4		
Partial load	900	5.0~15.0		
2-5 Solenoid	Max.cut-in voltage : 8 V Test voltage : 12~14 V			

3. Dimensions

K	3.2~3.4 mm
KF	5.7~5.9 mm
MS	1.1~1.3 mm
BCS	- mm
Control lever angle	
α	21.0~29.0 deg
A	- mm
β	36.0~46.0 deg
B	- mm
γ	10.5~11.5 deg
C	- mm

INJ. PUMP CALIBRATION DATA Distributor-type

TEST OIL:
I S O 4113 or
S A E J967d

ENGINE MODEL : LD20

Injection pump No: 104649-2002 [NP-VE4/9F2500RNP20]

Pump rotation : clockwise-viewed from drive side

Pre-stroke : - mm

BOSCH No.9 460 610 017
DKKC No. 104749-2002
Date : 20.Nov.1986 [3]
Company : NISSAN
No. 16700 W1701

For Test Condition see
Microfiche No.WP-210(N16)

1. Setting	Pump speed (rpm)	Settings	Charge air press(mmHg)	Difference in delivery(cc)
1-1 Timing device travel	900	1.1~ 1.7 (mm)		2.5
1-2 Supply pump pressure	900	2.9~ 3.5 (kg/cm ²)		
1-3 Full load delivery without charge air pressure	900	32.5~33.5 (cc/1,000st)		
		(cc/1,000st)		
1-4 Idle speed regulation	325	6.7~ 9.7 (cc/1,000st)		3.0
1-5 Start	100	Above 52 (cc/1,000st)		
1-6 Full-load speed regulation	2,700	7.2~13.2 (cc/1,000st)		
1-7				
1-8				

2. Test Specifications

2-1 Timing device	N = rpm mm	900 1.0~ 1.8	1,800 4.5~ 5.7	2,300 6.9~ 7.8
2-2 Supply pump	N = rpm kg/cm ²	900 2.8~ 3.6	1,800 4.9~ 5.7	2,300 6.2~ 7.0
2-3 Overflow delivery	N = rpm cc/10s	1,000 36.0~80.0		

2-4 Fuel injection quantities

Speed control lever position	Pump speed (rpm)	Fuel delivery (cc/1,000st)	Charge air press(mmHg)	Difference in delivery(cc)
Full speed position	900	32.0~34.0		
	600	31.2~35.2		
	2,300	30.6~34.6		
	2,700	6.7~13.7		
	2,800	Below 6		
Switch OFF	325	0		
Idling position	325	6.2~10.2		
	500	Below 4		
Partial load	900	5.0~15.0		
2-5 Solenoid	Max.cut-in voltage : 8 V Test voltage : 12~14 V			

3. Dimensions

K	3.2~3.4 mm
KF	5.7~5.9 mm
MS	1.1~1.3 mm
BCS	- mm
Control lever angle	
α	21.0~29.0 deg
A	- mm
β	36.0~46.0 deg
B	- mm
γ	10.5~11.5 deg
C	- mm

INJ. PUMP CALIBRATION DATA

Distributor-type

TEST OIL:
I S O 4113 or
S A E J967d

ENGINE MODEL : LD20

Injection pump No: 104649-2020 [NP-VE4/9F2500RNP52]

Pump rotation : clockwise-viewed from drive side

Pre-stroke : — mm

BOSCH No.9 460 610 072

DKKC No. 104749-2020

Date : 20.Nov.1986 [3]

Company : NISSAN

No. 16700 G3600

For Test Condition see
Microfiche No.WP-210(N16)

1. Setting	Pump speed (rpm)	Settings	Charge air press(mmHg)	Difference in delivery(cc)
1-1	900	1.1~ 1.7 (mm)		2.5
1-2	900	2.9~ 3.5 (kg/cm ²)		
1-3	900	32.5~33.5 (cc/1,000st) (cc/1,000st)		
1-4	325	6.7~ 9.7 (cc/1,000st)		3.0
1-5	100	Above 52 (cc/1,000st)		
1-6	2,700	7.2~13.2 (cc/1,000st)		
1-7				
1-8				

2. Test Specifications

2-1 Timing device	N = rpm mm	900 1.0~ 1.8	1,800 4.5~ 5.7	2,300 6.9~ 7.8
2-2 Supply pump	N = rpm kg/cm ²	900 2.8~ 3.6	1,800 4.9~ 5.7	2,300 6.2~ 7.0
2-3 Overflow delivery	N = rpm cc/10s	1,000 36.0~80.0		

Speed control lever position	Pump speed (rpm)	Fuel delivery (cc/1,000st)	Charge air press(mmHg)	Difference in delivery(cc)
Full speed position	900	32.0~34.0		
	600	31.2~35.2		
	2,300	30.6~34.6		
	2,700	6.7~13.7		
	2,800	Below 6		
Switch OFF	325	0		
Idling position	325	6.2~10.2		
	500	Below 4		
Partial load	900	5.0~15.0		
2-5 Solenoid	Max.cut-in voltage : 8 V Test voltage : 12~14 V			

3. Dimensions

K	3.2~3.4	mm
KF	5.7~5.9	mm
MS	1.1~1.3	mm
BCS	—	mm

Control lever angle

α	21.0~29.0	deg
A	—	mm
β	36.0~46.0	deg
B	—	mm
γ	10.5~11.5	deg
C	—	mm

INJ. PUMP CALIBRATION DATA

Distributor-type

TEST OIL:
I S O 4113 or
S A E J967d

ENGINE MODEL : LD20

Injection pump No: 104649-2030 [NP-VE4/9F2500RNP20]

Pump rotation : clockwise-viewed from drive side

Pre-stroke : — mm

BOSCH No.9 460 610 018

DKKC No. 104749-2030

Date : 20.Nov.1986 [3]

Company : NISSAN

No. 16700 W3410

For Test Condition see
Microfiche No.WP-210(N16)

1. Setting	Pump speed (rpm)	Settings	Charge air press(mmHg)	Difference in delivery(cc)
1-1	900	1.1~ 1.7 (mm)		2.5
1-2	900	2.9~ 3.5 (kg/cm ²)		
1-3	900	32.5~33.5 (cc/1,000st) (cc/1,000st)		
1-4	325	6.7~ 9.7 (cc/1,000st)		3.0
1-5	100	Above 52 (cc/1,000st)		
1-6	2,700	7.2~13.2 (cc/1,000st)		
1-7				
1-8				

2. Test Specifications

2-1 Timing device	N = rpm mm	900 1.0~ 1.8	1,800 4.5~ 5.7	2,300 6.9~ 7.8
2-2 Supply pump	N = rpm kg/cm ²	900 2.8~ 3.6	1,800 4.9~ 5.7	2,300 6.2~ 7.0
2-3 Overflow delivery	N = rpm cc/10s	1,000 36.0~80.0		

Speed control lever position	Pump speed (rpm)	Fuel delivery (cc/1,000st)	Charge air press(mmHg)	Difference in delivery(cc)
Full speed position	900	32.0~34.0		
	600	31.2~35.2		
	2,300	30.6~34.6		
	2,700	6.7~13.7		
	2,800	Below 6		
Switch OFF	325	0		
Idling position	325	6.2~10.2		
	500	Below 4		
Partial load	900	5.0~15.0		
2-5 Solenoid	Max.cut-in voltage : 8 V Test voltage : 12~14 V			

3. Dimensions

K	3.2~3.4	mm
KF	5.7~5.9	mm
MS	1.1~1.3	mm
BCS	—	mm

Control lever angle

α	21.0~29.0	deg
A	—	mm
β	36.0~46.0	deg
B	—	mm
γ	10.5~11.5	deg
C	—	mm

INJ. PUMP CALIBRATION DATA

Distributor-type

BOSCH No. 9 460 610 154
 DKKC No. 104749-2032
 Date: 20.Nov.1986
 Company: NISSAN
 No. 16700 W3410

TEST OIL:
 I S O 4113 or
 S A E J967d

ENGINE MODEL : LD20

Injection pump No: 104649-2032 [NP-VE4/9F2500RNP20]

Pump rotation : clockwise-viewed from drive side

For Test Condition see
 Microfiche No.WP-210(N16)

Pre-stroke : - mm

1. Setting	Pump speed (rpm)	Settings	Charge air press(mmHg)	Difference in delivery(cc)
1-1 Timing device travel	900	1.1~ 1.7 (mm)		2.5
1-2 Supply pump pressure	900	2.9~ 3.5 (kg/cm ²)		
1-3 Full load delivery without charge air pressure	900	32.5~33.5 (cc/1,000st)		
		(cc/1,000st)		
1-4 Idle speed regulation	325	6.7~ 9.7 (cc/1,000st)		
1-5 Start	100	Above 52 (cc/1,000st)		
1-6 Full-load speed regulation	2,700	7.2~13.2 (cc/1,000st)		
1-7				
1-8				

2. Test Specifications

2-1 Timing device	N = rpm	900	1,800	2,300
	mm	1.0~ 1.8	4.9~ 5.7	6.9~ 7.8
2-2 Supply pump	N = rpm	900	1,800	2,300
	kg/cm ²	2.8~ 3.6	4.9~ 5.7	6.2~ 7.0
2-3 Overflow delivery	N = rpm	1,000		
	cc/10s	36.0~80.0		
2-4 Fuel injection quantities				
Speed control lever position	Pump speed (rpm)	Fuel delivery (cc/1,000st)	Charge air press(mmHg)	Difference in delivery(cc)
Full speed position	900	32.0~34.0		
	600	31.2~35.2		
	2,300	30.6~34.6		
	2,700	6.7~13.7		
	2,800	Below 6		
Switch OFF	325	0		
Idling position	325	6.2~10.2		2.5
	500	Below 4		
Partial load	900	5.0~15.0		
2-5 Solenoid	Max.cut-in voltage : 8 V Test voltage : 12~14 V			

3. Dimensions

K	3.2~3.4	mm
KF	5.7~5.9	mm
MS	1.1~1.3	mm
BCS	-	mm

Control lever angle

α	56.0~60.0	deg
YA	8.9~13.2	mm
β	36.0~46.0	deg
B	11.0~14.5	mm
γ	10.5~11.5	deg
C	6.7~ 7.3	mm

Control Lever Angle Measurement Position

① Measure the control lever angles (α, β, γ) at hole A.

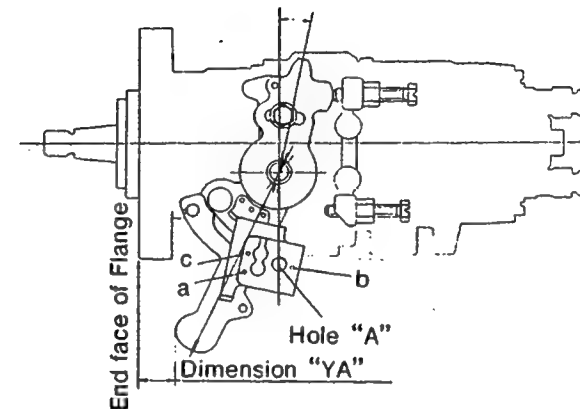

M - 5

INJ. PUMP CALIBRATION DATA Distributor-type

TEST OIL:
I S O 4113 or
S A E J967d

ENGINE MODEL : LD20

BOSCH No.9 460 610 073

DKKC No. 104749-2050

Date : 20.Nov.1986 3

Company : NISSAN

No. 16700 G3610

Injection pump No: 104649-2050 [NP-VE4/9F2500RNP52]

Pump rotation : clockwise-viewed from drive side

For Test Condition see
Microfiche No.WP-210(N16)

Pre-stroke : - mm

1. Setting	Pump speed (rpm)	Settings	Charge air press(mmHg)	Difference in delivery(cc)
1-1 Timing device travel	900	1.1~ 1.7 (mm)		
1-2 Supply pump pressure	900	2.9~ 3.5 (kg/cm ²)		
1-3 Full load delivery without charge air pressure	900	32.5~33.5 (cc/1,000st)		2.5
Full load delivery with charge air pressure		(cc/1,000st)		
1-4 Idle speed regulation	325	6.7~ 9.7 (cc/1,000st)		3.0
1-5 Start	100	Above 52 (cc/1,000st)		
1-6 Full-load speed regulation	2,700	7.2~13.2 (cc/1,000st)		
1-7				
1-8				

2. Test Specifications

2-1 Timing device	N = rpm	900	1,800	2,300	
	mm	1.0~ 1.8	4.5~ 5.7	6.9~ 7.8	
2-2 Supply pump	N = rpm	900	1,800	2,300	
	kg/cm ²	2.8~ 3.6	4.9~ 5.7	6.2~ 7.0	
2-3 Overflow delivery	N = rpm	1,000			
	cc/10s	36.0~80.0			
2-4 Fuel injection quantities					
Speed control lever position	Pump speed (rpm)	Fuel delivery (cc/1,000st)	Charge air press(mmHg)	Difference in delivery(cc)	
Full speed position	900	32.0~34.0			
	600	31.2~35.2			
	2,300	30.6~34.6			
	2,700	6.7~13.7			
	2,800	Below 6			
Switch OFF	325	0			
Idling position	325	6.2~10.2			
	500	Below 4			
Partial load	900	5.0~15.0			
2-5 Solenoid	Max.cut-in voltage : 8 V Test voltage : 12~14 V				

3. Dimensions

K	3.2~3.4	mm
KF	5.7~5.9	mm
MS	1.1~1.3	mm
BCS	-	mm

Control lever angle

α	21.0~29.0	deg
A	-	mm
β	36.0~46.0	deg
B	-	mm
γ	10.5~11.5	deg
C	-	mm



DIESEL KIKI

DIESEL KIKI CO., LTD.

Service Department

3-6-7 SHIBUYA, SHIBUYA-KU, TOKYO 150, JAPAN

Tel. (03) 400-1551 · Fax: (03) 499-4115

INJ. PUMP CALIBRATION DATA

Distributor-type

TEST OIL:
I S O 4113 or
S A E J967d

ENGINE MODEL : LD20

Injection pump No: 104649-2052 [NP-VE4/9F2500RNP52]

BOSCH No.9 460 610 155
DKKC No. 104749-2052
Date : 20.Nov.1986 [0]
Company : NISSAN
No. 16700 G3610

Pump rotation : clockwise-viewed from drive side

For Test Condition see
Microfiche No.WP-210(N16)

Pre-stroke : - mm

1. Setting	Pump speed (rpm)	Settings	Charge air press(mmHg)	Difference in delivery(cc)
1-1 Timing device travel	900	1.1~ 1.7 (mm)		2.5
1-2 Supply pump pressure	900	2.9~ 3.5 (kg/cm ²)		
1-3 Full load delivery without charge air pressure	900	32.5~33.5 (cc/1,000st)		
		(cc/1,000st)		
1-4 Idle speed regulation	325	6.7~ 9.7 (cc/1,000st)		
1-5 Start	100	Above 52 (cc/1,000st)		
1-6 Full-load speed regulation	2,700	7.2~13.2 (cc/1,000st)		
1-7				
1-8				

2. Test Specifications

2-1 Timing device	N = rpm	900	1,800	2,300	
	mm	1.0~ 1.8	4.9~ 5.7	6.9~ 7.8	
2-2 Supply pump	N = rpm	900	1,800	2,300	
	kg/cm ²	2.8~ 3.6	4.9~ 5.7	6.2~ 7.0	
2-3 Overflow delivery	N = rpm	1,000			
	cc/10s	36.0~80.0			
2-4 Fuel injection quantities					
Speed control lever position	Pump speed (rpm)	Fuel delivery (cc/1,000st)	Charge air press(mmHg)	Difference in delivery(cc)	
Full speed position	900	32.0~34.0			
	600	31.2~35.2			
	2,300	30.6~34.6			
	2,700	6.7~13.7			
	2,800	Below 6			
Switch OFF	325	0			
Idling position	325	6.2~10.2		2.5	
	500	Below 4			
Partial load	900	5.0~15.0			
2-5 Solenoid	Max.cut-in voltage : 8 V Test voltage : 12~14 V				

3. Dimensions

K	3.2~3.4	mm
KF	5.7~5.9	mm
MS	1.1~1.3	mm
BCS	-	mm
Control lever angle		
α	56.0~60.0	deg
YA	8.9~13.2	mm
β	36.0~46.0	deg
B	11.0~14.5	mm
γ	10.5~11.5	deg
C	6.7~ 7.3	mm

Control Lever Angle Measurement Position

① Measure the control lever angles (α, β, γ) at hole A.

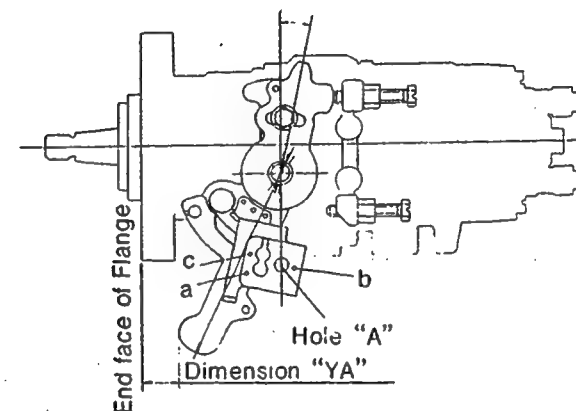

INJ. PUMP CALIBRATION DATA Distributor-type

TEST OIL:
I S O 4113 or
S A E J967d

ENGINE MODEL : LD20

Injection pump No: 104649-2002 (NP-VE4/9F2500RNP20)

Pump rotation : clockwise-viewed from drive side
Pre-stroke : — mm

BOSCH No.9 460 610 074
DKKC No. 104749-2060
Date : 20.Nov.1986 3
Company : NISSAN
No. 16700 W1791

For Test Condition see
Microfiche No.WP-210(N16)

1. Setting	Pump speed (rpm)	Settings	Charge air press(mmHg)	Difference in delivery(cc)
1-1 Timing device travel	900	1.1~ 1.7 (mm)		
1-2 Supply pump pressure	900	2.9~ 3.5 (kg/cm ²)		
1-3 Full load delivery without charge air pressure	900	32.5~33.5 (cc/1,000st)		2.5
Full load delivery with charge air pressure		(cc/1,000st)		
1-4 Idle speed regulation	325	6.7~ 9.7 (cc/1,000st)		3.0
1-5 Start	100	Above 52 (cc/1,000st)		
1-6 Full-load speed regulation	2,700	7.2~13.2 (cc/1,000st)		
1-7				
1-8				

2. Test Specifications

2-1 Timing device	N = rpm mm	900 1.0~ 1.8	1,800 4.5~ 5.7	2,300 6.9~ 7.8
2-2 Supply pump	N = rpm kg/cm ²	900 2.8~ 3.6	1,800 4.9~ 5.7	2,300 6.2~ 7.0
2-3 Overflow delivery	N = rpm cc/10s	1,000 36.0~80.0		

2-4 Fuel injection quantities

Speed control lever position	Pump speed (rpm)	Fuel delivery (cc/1,000st)	Charge air press(mmHg)	Difference in delivery(cc)
Full speed position	900	32.0~34.0		
	600	31.2~35.2		
	2,300	30.6~34.6		
	2,700	6.7~13.7		
	2,800	Below 6		
Switch OFF	325	0		
Idling position	325	6.2~10.2		
	500	Below 4		
Partial load	900	5.0~15.0		
2-5 Solenoid	Max.cut-in voltage : 8 V Test voltage : 12~14 V			

3. Dimensions

K	3.2~3.4 mm
KF	5.7~5.9 mm
MS	1.1~1.3 mm
BCS	— mm
Control lever angle	
α	21.0~29.0 deg
A	— mm
β	36.0~46.0 deg
B	— mm
γ	10.5~11.5 deg
C	— mm

INJ. PUMP CALIBRATION DATA Distributor-type

TEST OIL:
I S O 4113 or
S A E J967d

ENGINE MODEL : LD20

Injection pump No: 104649-2020 (NP-VE4/9F2500RNP52)

Pump rotation : clockwise-viewed from drive side
Pre-stroke : — mm

BOSCH No.9 460 610 075
DKKC No. 104749-2070
Date : 20.Nov.1986 3
Company : NISSAN
No. 16700 G3690

For Test Condition see
Microfiche No.WP-210(N16)

1. Setting	Pump speed (rpm)	Settings	Charge air press(mmHg)	Difference in delivery(cc)
1-1 Timing device travel	900	1.1~ 1.7 (mm)		
1-2 Supply pump pressure	900	2.9~ 3.5 (kg/cm ²)		
1-3 Full load delivery without charge air pressure	900	32.5~33.5 (cc/1,000st)		2.5
Full load delivery with charge air pressure		(cc/1,000st)		
1-4 Idle speed regulation	325	6.7~ 9.7 (cc/1,000st)		3.0
1-5 Start	100	Above 52 (cc/1,000st)		
1-6 Full-load speed regulation	2,700	7.2~13.2 (cc/1,000st)		
1-7				
1-8				

2. Test Specifications

2-1 Timing device	N = rpm mm	900 1.0~ 1.8	1,800 4.5~ 5.7	2,300 6.9~ 7.8
2-2 Supply pump	N = rpm kg/cm ²	900 2.8~ 3.6	1,800 4.9~ 5.7	2,300 6.2~ 7.0
2-3 Overflow delivery	N = rpm cc/10s	1,000 36.0~80.0		

2-4 Fuel injection quantities

Speed control lever position	Pump speed (rpm)	Fuel delivery (cc/1,000st)	Charge air press(mmHg)	Difference in delivery(cc)
Full speed position	900	32.0~34.0		
	600	31.2~35.2		
	2,300	30.6~34.6		
	2,700	6.7~13.7		
	2,800	Below 6		
Switch OFF	325	0		
Idling position	325	6.2~10.2		
	500	Below 4		
Partial load	900	5.0~15.0		
2-5 Solenoid	Max.cut-in voltage : 8 V Test voltage : 12~14 V			

3. Dimensions

K	3.2~3.4 mm
KF	5.7~5.9 mm
MS	1.1~1.3 mm
BCS	— mm
Control lever angle	
α	21.0~29.0 deg
A	— mm
β	36.0~46.0 deg
B	— mm
γ	10.5~11.5 deg
C	— mm

INJ. PUMP CALIBRATION DATA Distributor-type

ENGINE MODEL : LD20

TEST OIL:
I S O 4113 or
S A E J967d

Injection pump No: 104649-2060 [NP-VE4/9F2200RNP192]

Pump rotation : clockwise-viewed from drive side

Pre-stroke : — mm

BOSCH No.9 460 610 076
DKKC No. 104749-2080
Date : 20.Nov.1986 [0]
Company : NISSAN
No. 16700 G4100

For Test Condition see
Microfiche No.WP-210(N16)

1. Setting	Pump speed (rpm)	Settings	Charge air press(mmHg)	Difference in delivery(cc)
1-1 Timing device travel	900	1.1~ 1.7 (mm)		
1-2 Supply pump pressure	900	2.9~ 3.5 (kg/cm ²)		
1-3 Full load delivery without charge air pressure	900	32.5~33.5 (cc/1,000st)		3.0
Full load delivery with charge air pressure		(cc/1,000st)		
1-4 Idle speed regulation	325	6.7~ 9.7 (cc/1,000st)		2.5
1-5 Start	100	Above 52 (cc/1,000st)		
1-6 Full-load speed regulation	2,500	10.2~16.2 (cc/1,000st)		
1-7				
1-8				

2. Test Specifications

2-1 Timing device	N = rpm mm	900 1.0~ 1.8	1,800 4.5~ 5.7	2,200 6.7~ 7.8
2-2 Supply pump	N = rpm kg/cm ²	900 2.8~ 3.6	1,800 4.9~ 5.7	2,200 5.8~ 6.6
2-3 Overflow delivery	N = rpm cc/10s	1,000 36.0~80.0		

2-4 Fuel injection quantities

Speed control lever position	Pump speed (rpm)	Fuel delivery (cc/1,000st)	Charge air press(mmHg)	Difference in delivery(cc)
Full speed position:	900	32.0~34.0		
	600	31.2~35.2		
	2,200	31.1~35.1		
	2,500	9.7~16.7		
	2,800	Below 4		
Switch OFF	325	0		
Idling position	325	6.2~10.2		
	500	Below 4		
Partial load	900	5.0~15.0		
2-5 Solenoid	Max.cut-in voltage : 8 V Test voltage : 12~14 V			

3. Dimensions

K	3.2~3.4 mm
KF	5.7~5.9 mm
MS	1.1~1.3 mm
BCS	— mm
Control lever angle	
α	21.0~29.0 deg
A	2.5~8.0 mm
β	36.0~46.0 deg
B	10.5~15.0 mm
γ	10.5~11.5 deg
C	6.7~7.3 mm

INJ. PUMP CALIBRATION DATA Distributor-type

ENGINE MODEL : LD20

TEST OIL:
I S O 4113 or
S A E J967d

Injection pump No: 104649-2120 [NP-VE4/9F2500RNP20]

Pump rotation : clockwise-viewed from drive side

Pre-stroke : — mm

BOSCH No.9 460 610 077
DKKC No. 104749-2150
Date : 20.Nov.1986 [3]
Company : NISSAN
No. 16700 43S00

For Test Condition see
Microfiche No.WP-210(N16)

1. Setting	Pump speed (rpm)	Settings	Charge air press(mmHg)	Difference in delivery(cc)
1-1 Timing device travel	900	1.1~ 1.7 (mm)		
1-2 Supply pump pressure	900	2.9~ 3.5 (kg/cm ²)		
1-3 Full load delivery without charge air pressure	900	32.5~33.5 (cc/1,000st)		2.5
Full load delivery with charge air pressure		(cc/1,000st)		
1-4 Idle speed regulation	325	6.7~ 9.7 (cc/1,000st)		3.0
1-5 Start	100	Above 52 (cc/1,000st)		
1-6 Full-load speed regulation	2,700	7.2~13.2 (cc/1,000st)		
1-7				
1-8				

2. Test Specifications

2-1 Timing device	N = rpm mm	900 1.0~ 1.8	1,800 4.5~ 5.7	2,300 6.9~ 7.8
2-2 Supply pump	N = rpm kg/cm ²	900 2.8~ 3.6	1,800 4.9~ 5.7	2,300 6.2~ 7.0
2-3 Overflow delivery	N = rpm cc/10s	1,000 36.0~80.0		

2-4 Fuel injection quantities

Speed control lever position	Pump speed (rpm)	Fuel delivery (cc/1,000st)	Charge air press(mmHg)	Difference in delivery(cc)
Full speed position	900	32.0~34.0		
	600	31.2~35.2		
	2,300	30.6~34.6		
	2,700	6.7~13.7		
	2,800	Below 6		
Switch OFF	325	0		
Idling position	325	6.2~10.2		
	500	Below 4		
Partial load	900	5.0~15.0		
2-5 Solenoid	Max.cut-in voltage : 8 V Test voltage : 12~14 V			

3. Dimensions

K	3.2~3.4 mm
KF	5.7~5.9 mm
MS	1.1~1.3 mm
BCS	— mm
Control lever angle	
α	21.0~29.0 deg
A	— mm
β	36.0~46.0 deg
B	— mm
γ	10.5~11.5 deg
C	— mm

INJ. PUMP CALIBRATION DATA

Distributor-type

TEST OIL:
I S O 4113 or
S A E J967d

ENGINE MODEL : LD28

Injection pump No: 104660-2002 [NP-VE6/10F2500RNP1]

BOSCH No.9 460 610 177

DKKC No. 104760-2011

Date: 20.Nov.1986 2

Company: NISSAN

No. 16700V0762

Pump rotation : clockwise-viewed from drive side

For Test Condition see
Microfiche No.WP-210(N16)

Pre-stroke : — mm

1. Setting	Pump speed (rpm)	Settings	Charge air press(mmHg)	Difference in delivery(cc)
1-1 Timing device travel	1,200	2.4~ 3.0 (mm)		
1-2 Supply pump pressure	1,800	5.7~ 6.3 (kg/cm ²)		
1-3 Full load delivery without charge air pressure	1,200	29.6~30.6 (cc/1,000st)		2.5
Full load delivery with charge air pressure		(cc/1,000st)		
1-4 Idle speed regulation	350	6.7~ 9.7 (cc/1,000st)		3.0
1-5 Start	100	Above 47 (cc/1,000st)		
1-6 Full-load speed regulation	2,700	7.0~13.0 (cc/1,000st)		
1-7				
1-8				

2. Test Specifications

2-1 Timing device	N = rpm	1,200	1,800	2,300
	mm	2.3~ 3.1	4.8~ 6.0	7.7~ 8.6
2-2 Supply pump	N = rpm	800	1,800	2,500
	kg/cm ²	3.3~ 4.1	5.6~ 6.4	7.1~ 7.9
2-3 Overflow delivery	N = rpm	1,000		
	cc/10s	53.0~97.0		
2-4 Fuel injection quantities				
Speed control lever position	Pump speed (rpm)	Fuel delivery (cc/1,000st)	Charge air press(mmHg)	Difference in delivery(cc)
Full speed position	1,200	29.1~31.1		
	600	21.4~25.4		
	2,300	25.3~29.3		
	2,700	6.5~13.5		
	2,800	Below 5		
Switch OFF	350	0		
Idling position	350	6.2~10.2		
	500	Below 4		
Partial load	900	8.1~18.1		
2-5 Solenoid	Max.cut-in voltage : 8 V Test voltage : 12~14 V			

3. Dimensions

K	3.2~3.4	mm
KF	6.54~6.74	mm
MS	1.7~1.9	mm
BCS	—	mm
Control lever angle		
α	21.0~29.0	deg
A	2.5~8	mm
β	39.0~49.0	deg
B	11.0~16.0	mm
γ	10.5~11.5	deg
C	6.7~7.3	mm

INJ. PUMP CALIBRATION DATA

Distributor-type

BOSCH No.9 460 610 045

DKKC No. 104740-3560

Date: 20.Nov.1985 0

Company: MITSUBISHI

No. MD079394

104740-3560

TEST OIL:
ISO 4113 or
SAE J967d

ENGINE MODEL : 4D55T

Injection pump No: 104640-3290 [NP-VE4/10F2100RNP270]

Pump rotation : clockwise-viewed from drive side

For Test Condition see
Microfiche No.WP-210(N16)

Pre-stroke : - mm

1. Setting		Pump speed (rpm)	Settings	Charge air press(mmHg)	Difference in delivery(cc)
1-1	Timing device travel	1,250	3.1~ 3.5 (mm)	0	
1-2	Supply pump pressure	1,250	4.5~ 5.1 (kg/cm ²)	0	
1-3	Full load delivery without charge air pressure	600	35.7~36.7 (cc/1,000st)	0	3.0
	Full load delivery with charge air pressure	750	42.8~43.8 (cc/1,000st)	170~190	
1-4	Idle speed regulation	375	6.5~ 9.5 (cc/1,000st)	0	2.0
1-5	Start	100	63.0~83.0 (cc/1,000st)	0	
1-6	Full-load speed regulation	2,350	17.1~23.1 (cc/1,000st)	510~530	6.0
1-7					
1-8					

2. Test Specifications

2-1	Timing device	N = rpm mm	750 0.5~ 1.7	1,250 2.9~ 3.7	1,750 4.9~ 6.1	2,100 6.6~ 7.4
2-2	Supply pump	N = rpm kg/cm ²	600 2.9~ 3.5	1,250 4.5~ 5.1	2,100 6.5~ 7.1	
2-3	Overflow delivery	N = rpm cc/10s	1,250 48.0~52.0			
2-4 Fuel injection quantities						
	Speed control lever position	Pump speed (rpm)	Fuel delivery (cc/1,000st)	Charge air press(mmHg)	Difference in delivery(cc)	
Full speed position		600	35.2~37.2	0		
		750	42.3~44.3	170~190		
		1,250	53.8~58.8	510~530		
		2,100	48.3~53.3	510~530		
		2,350	15.1~25.1	510~530		
		2,500	Below 5	510~530		
Switch OFF		375	0			
Idling position		600	Below 3			
		375	6.0~10.0			
2-5 Solenoid	Max.cut-in voltage : 8 V Test voltage : 12~14 V					

3. Dimensions

K	3.2~3.4	mm
KF	5.7~5.9	mm
MS	1.3~1.5	mm
BCS	4.7~4.9	mm

Control lever angle

α	55.0~63.0	deg
A	10.5~16.0	mm
β	41.0~51.0	deg
B	12.5~16.5	mm
γ	—	deg
C	—	mm

○ Note

■ After adjustment of full load fuel injection quantity (600 rpm), set the boost pressure at 180 mmHg or 0.25 kg/cm², and at pump speed of 750 rpm adjust the fuel injection quantity using the BCS spring set screw.

○ Note

■ Check that the injection quantity is within the specified range even when the boost pressure exceeds 700 mmHg.

Table of Contents (DKKC No. — BOSCH No.)

DKKC No.	BOSCH No.	Location	DKKC No.	BOSCH No.	Location
104564-2120	9 460 610 000	WP-211 B-1 ~B-2	104740-4270	9 460 610 006	WP-211 K-3
104740-0091	9 460 610 094	WP-211 I-16	104740-4300	9 460 610 007	WP-211 B-14
104740-1021	9 460 610 099	WP-211 B-3	104740-4360	9 460 610 051	WP-211 B-15
104740-1022	9 460 610 127	WP-211 B-4	104740-4370	9 460 610 008	WP-211 K-4
			104740-4380	9 460 610 009	WP-211 K-4
104740-1121	9 460 610 131	WP-211 B-5	104740-4400	9 460 610 010	WP-211 B-15
104740-1280	9 460 610 183	WP-211 B-6	104740-4410	9 460 610 052	WP-211 B-16
104740-1290	9 460 610 184	WP-211 B-6	104740-4420	9 460 610 053	WP-211 B-16
104740-1300	9 460 610 185	WP-211 B-7	104740-4460	9 460 610 134	WP-211 C-1
104740-1310	9 460 610 186	WP-211 B-7	104740-4500	9 460 610 135	WP-211 C-1
104740-2000	9 460 610 023	WP-211 J-1	104740-4520	9 460 610 136	WP-211 C-2
104740-2002	9 460 610 024	WP-211 J-2	104740-4570	9 460 610 137	WP-211 C-2
104740-2020	9 460 610 025	WP-211 J-3	104740-4580	9 460 610 138	WP-211 C-3
104740-2021	9 460 610 026	WP-211 J-4	104740-4701	9 460 610 139	WP-211 C-3
104740-2022	9 460 610 027	WP-211 J-5	104740-4770	9 460 610 140	WP-211 C-4 ~C-5
104740-2030	9 460 610 028	WP-211 J-6	104740-4800	9 460 610 141	WP-211 C-6 ~C-7
104740-2031	9 460 610 029	WP-211 J-7	104740-4810	9 460 610 142	WP-211 C-8 ~C-9
104740-2042	9 460 610 176	WP-211 B-8 ~B-9	104748-0060	9 460 610 180	WP-211 K-5
104740-3010	9 460 610 001	WP-211 J-8 ~J-9	104748-0133	9 460 610 143	WP-211 C-10~C-11
104740-3011	9 460 610 002	WP-211 J-10~J-11	104748-0134	9 460 610 188	WP-211 C-12~C-13
104740-3030	9 460 610 030	WP-211 J-12~J-13	104748-0144	9 460 610 189	WP-211 C-14~C-16
104740-3031	9 460 610 031	WP-211 J-14~J-15	104748-0152	9 460 610 144	WP-211 D-1 ~D-2
104740-3100	9 460 610 033	WP-211 B-10	104748-0153	9 460 610 190	WP-211 D-3 ~D-4
104740-3200	9 460 610 034	WP-211 J-16	104748-0162	9 460 610 145	WP-211 D-5 ~D-6
104740-3480	9 460 610 168	WP-211 B-11	104748-0172	9 460 610 011	WP-211 K-6 ~K-8
104740-3500	9 460 610 169	WP-211 B-12	104748-0173	9 460 610 126	WP-211 D-7 ~D-9
104740-3540	9 460 610 004	WP-211 K-1	104748-0181	9 460 610 146	WP-211 D-10~D-11
104740-3551	9 460 610 044	WP-211 K-2	104748-0182	9 460 610 192	WP-211 D-12~D-13
104740-3560	9 460 610 045	WP-211 M-10	104748-0243	9 460 610 147	WP-211 D-14~D-16
104740-4160	9 460 610 048	WP-211 B-13	104748-2011	9 460 610 012	WP-211 E-1
104740-4231	9 460 610 049	WP-211 B-13	104748-2050	9 460 610 148	WP-211 K-8 ~K-11
104740-4250	9 460 610 050	WP-211 K-3	104748-2061	9 460 610 056	WP-211 K-12~K-13
104740-4260	9 460 610 005	WP-211 B-14	104748-2081	9 460 610 057	WP-211 K-14~K-15

Table of Contents (DKKC No. — BOSCH No.)

DKKC No.	BOSCH No.	Location	DKKC No.	BOSCH No.	Location
104748-2140	9 460 610 058	WP-211 L-1 ~L-2	104749-2030	9 460 610 018	WP-211 M-3
104748-2160	9 460 610 060	WP-211 L-3 ~L-4	104749-2032	9 460 610 154	WP-211 M-4
104748-2280	9 460 610 062	WP-211 L-5 ~L-6	104749-2050	9 460 610 073	WP-211 M-5
104748-2300	9 460 610 064	WP-211 L-7 ~L-8	104749-2052	9 460 610 155	WP-211 M-6
104748-2370	9 460 610 066	WP-211 L-9 ~L-10	104749-2060	9 460 610 074	WP-211 M-7
104748-2390	9 460 610 068	WP-211 L-11~L-12	104749-2070	9 460 610 075	WP-211 M-7
104748-2410	9 460 610 149	WP-211 E-2 ~E-3	104749-2080	9 460 610 076	WP-211 M-8
104748-2420	9 460 610 150	WP-211 E-4 ~E-5	104749-2082	9 460 610 128	WP-211 F-13
104748-2430	9 460 610 151	WP-211 E-6 ~E-7	104749-2130	9 460 610 019	WP-211 F-14
104748-2440	9 460 610 152	WP-211 E-8 ~E-9	104749-2141	9 460 610 097	WP-211 F-15~F-16
104749-0040	9 460 610 172	WP-211 E-10	104749-2142	9 460 610 124	WP-211 G-1 ~G-2
104749-1070	9 460 610 105	WP-211 E-10	104749-2150	9 460 610 077	WP-211 M-8
104749-1390	9 460 610 109	WP-211 E-11~E-12	104749-2170	9 460 610 093	WP-211 G-3
104749-1400	9 460 610 110	WP-211 E-13~E-14	104749-2180	9 460 610 129	WP-211 G-4
104749-1410	9 460 610 111	WP-211 E-15~E-16	104749-2180	9 460 610 129	WP-211 G-4
104749-1420	9 460 610 112	WP-211 F-1 ~F-2	104749-2190	9 460 610 156	WP-211 G-5 ~G-6
104749-1490	9 460 610 113	WP-211 L-13	104749-2210	9 460 610 157	WP-211 G-7 ~G-8
104749-1491	9 460 610 153	WP-211 F-2	104749-2220	9 460 610 158	WP-211 G-9 ~G-10
104749-1500	9 460 610 114	WP-211 L-14	104749-3010	9 460 610 079	WP-211 G-11~G-12
104749-1520	9 460 610 116	WP-211 L-15	104749-3020	9 460 610 080	WP-211 G-13~G-14
104749-1530	9 460 610 117	WP-211 L-16	104749-3031	9 460 610 197	WP-211 H-1 ~H-3
104749-1540	9 460 610 118	WP-211 F-3 ~F-4	104749-4110	9 460 610 170	WP-211 H-4
104749-1550	9 460 610 119	WP-211 F-5 ~F-6	104749-4111	9 460 610 020	WP-211 H-4
104749-1560	9 460 610 120	WP-211 F-7 ~F-8	104749-6021	9 460 610 181	WP-211 H-5
104749-1570	9 460 610 121	WP-211 F-9 ~F-10	104749-6500	9 460 610 198	WP-211 H-5
104749-1600	9 460 610 179	WP-211 M-1	104749-6510	9 460 610 199	WP-211 H-6
104749-1840	9 460 610 098	WP-211 F-11	104760-2001	9 460 610 081	WP-211 H-7
104749-1841	9 460 610 174	WP-211 F-11	104760-2002	9 460 610 021	WP-211 H-7
104749-1990	9 460 610 175	WP-211 F-12	104760-2011	9 460 610 177	WP-211 M-9
104749-2000	9 460 610 070	WP-211 M-1	104760-2020	9 460 610 082	WP-211 H-8
104749-2001	9 460 610 071	WP-211 M-2	104760-2021	9 460 610 083	WP-211 H-8
104749-2002	9 460 610 017	WP-211 M-2	104760-2070	9 460 610 084	WP-211 H-9
104749-2020	9 460 610 072	WP-211 M-3	104760-2111	9 460 610 085	WP-211 H-9
			104760-2132	9 460 610 086	WP-211 H-10

Table of Contents (BOSCH No. — DKKC No.)

BOSCH No.	DKKC No.	Location	BOSCH No.	DKKC No.	Location
9 460 610 181	104749-6021	WP-211 H- 5			
9 460 610 183	104740-1280	WP-211 B- 6			
9 460 610 184	104740-1290	WP-211 B- 6			
9 460 610 185	104740-1300	WP-211 B- 7			
9 460 610 186	104740-1310	WP-211 B- 7			
9 460 610 188	104748-0134	WP-211 C-12~C-13			
9 460 610 189	104748-0144	WP-211 C-14~C-16			
9 460 610 190	104748-0153	WP-211 D- 3 ~D- 4			
9 460 610 192	104748-0182	WP-211 D-12~D-13			
9 460 610 197	104749-3031	WP-211 H- 1 ~H- 3			
9 460 610 198	104749-6500	WP-211 H- 5			
9 460 610 199	104749-6510	WP-211 H- 6			
9 460 610 200	104769-2103	WP-211 I-10~I-11			
9 460 610 201	104769-2113	WP-211 I-14~I-15			

Table of Contents (BOSCH No. — DKKC No.)

Table of Contents (BOSCH No. — DKKC No.)

BOSCH No.	DKKC No.	Location	BOSCH No.	DKKC No.	Location
9 460 610 000	104564-2120	WP-211 B-1 ~B-2	9 460 610 051	104740-4360	WP-211 B-15
9 460 610 001	104740-3010	WP-211 J-8 ~J-9	9 460 610 052	104740-4410	WP-211 B-16
9 460 610 002	104740-3011	WP-211 J-10~J-11	9 460 610 053	104740-4420	WP-211 B-16
9 460 610 004	104740-3540	WP-211 K-1	9 460 610 056	104748-2061	WP-211 K-12~K-13
9 460 610 005	104740-4260	WP-211 B-14	9 460 610 057	104748-2081	WP-211 K-14~K-15
9 460 610 006	104740-4270	WP-211 K-3	9 460 610 058	104748-2140	WP-211 L-1 ~L-2
9 460 610 007	104740-4300	WP-211 B-14	9 460 610 060	104748-2160	WP-211 L-3 ~L-4
9 460 610 008	104740-4370	WP-211 K-4	9 460 610 062	104748-2280	WP-211 L-5 ~L-6
9 460 610 009	104740-4380	WP-211 K-4	9 460 610 064	104748-2300	WP-211 L-7 ~L-8
9 460 610 010	104740-4400	WP-211 B-15	9 460 610 066	104748-2370	WP-211 L-9 ~L-10
9 460 610 011	104748-0172	WP-211 K-6 ~K-8	9 460 610 068	104748-2390	WP-211 L-11~L-12
9 460 610 012	104748-2011	WP-211 E-1	9 460 610 070	104749-2000	WP-211 M-1
9 460 610 017	104749-2002	WP-211 M-2	9 460 610 071	104749-2001	WP-211 M-2
9 460 610 018	104749-2030	WP-211 M-3	9 460 610 072	104749-2020	WP-211 M-3
9 460 610 019	104749-2130	WP-211 F-14	9 460 610 073	104749-2050	WP-211 M-5
9 460 610 020	104749-4111	WP-211 H-4	9 460 610 074	104749-2060	WP-211 M-7
9 460 610 021	104760-2002	WP-211 H-7	9 460 610 075	104749-2070	WP-211 M-7
9 460 610 023	104740-2000	WP-211 J-1	9 460 610 076	104749-2080	WP-211 M-8
9 460 610 024	104740-2002	WP-211 J-2	9 460 610 077	104749-2150	WP-211 M-8
9 460 610 025	104740-2020	WP-211 J-3	9 460 610 079	104749-3010	WP-211 G-11~G-12
9 460 610 026	104740-2021	WP-211 J-4	9 460 610 080	104749-3020	WP-211 G-13~G-14
9 460 610 027	104740-2022	WP-211 J-5	9 460 610 081	104760-2001	WP-211 H-7
9 460 610 028	104740-2030	WP-211 J-6	9 460 610 082	104760-2020	WP-211 H-8
9 460 610 029	104740-2031	WP-211 J-7	9 460 610 083	104760-2021	WP-211 H-8
9 460 610 030	104740-3030	WP-211 J-12~J-13	9 460 610 084	104760-2070	WP-211 H-9
9 460 610 031	104740-3031	WP-211 J-14~J-15	9 460 610 085	104760-2111	WP-211 H-9
9 460 610 033	104740-3100	WP-211 B-10	9 460 610 086	104760-2132	WP-211 H-10
9 460 610 034	104740-3200	WP-211 J-16	9 460 610 087	104760-2133	WP-211 H-10
9 460 610 044	104740-3551	WP-211 K-2	9 460 610 088	104760-2160	WP-211 H-11
9 460 610 045	104740-3560	WP-211 M-10	9 460 610 089	104760-2230	WP-211 H-12
9 460 610 048	104740-4160	WP-211 B-13	9 460 610 090	104760-2240	WP-211 H-14
9 460 610 049	104740-4231	WP-211 B-13	9 460 610 091	104760-2242	WP-211 H-15
9 460 610 050	104740-4250	WP-211 K-3	9 460 610 092	104769-2023	WP-211 I-1 ~I-2

BOSCH No.	DKKC No.	Location	BOSCH No.	DKKC No.	Location
9 460 610 093	104749-2170	WP-211 G-3	9 460 610 142	104740-4810	WP-211 C-8 ~C-9
9 460 610 094	104740-0091	WP-211 I-16	9 460 610 143	104748-0133	WP-211 C-10~C-11
9 460 610 097	104749-2141	WP-211 F-15~F-16	9 460 610 144	104748-0152	WP-211 D-1 ~D-2
9 460 610 098	104749-1840	WP-211 F-11	9 460 610 145	104748-0162	WP-211 D-5 ~D-6
9 460 610 099	104740-1021	WP-211 B-3	9 460 610 146	104748-0181	WP-211 D-10~D-11
			9 460 610 147	104748-0243	WP-211 D-14~D-16
9 460 610 105	104749-1070	WP-211 E-10	9 460 610 148	104748-2050	WP-211 K-8 ~K-11
9 460 610 109	104749-1390	WP-211 E-11~E-12	9 460 610 149	104748-2410	WP-211 E-2 ~E-3
9 460 610 110	104749-1400	WP-211 E-13~E-14	9 460 610 150	104748-2420	WP-211 E-4 ~E-5
9 460 610 111	104749-1410	WP-211 E-15~E-16	9 460 610 151	104748-2430	WP-211 E-6 ~E-7
9 460 610 112	104749-1420	WP-211 F-1 ~F-2	9 460 610 152	104748-2440	WP-211 E-8 ~E-9
9 460 610 113	104749-1490	WP-211 L-13	9 460 610 153	104749-1491	WP-211 F-2
9 460 610 114	104749-1500	WP-211 L-14	9 460 610 154	104749-2032	WP-211 M-4
9 460 610 116	104749-1520	WP-211 L-15	9 460 610 155	104749-2052	WP-211 M-6
9 460 610 117	104749-1530	WP-211 L-16	9 460 610 156	104749-2190	WP-211 G-5 ~G-6
9 460 610 118	104749-1540	WP-211 F-3 ~F-4	9 460 610 157	104749-2210	WP-211 G-7 ~G-8
9 460 610 119	104749-1550	WP-211 F-5 ~F-6	9 460 610 158	104749-2220	WP-211 G-9 ~G-10
9 460 610 120	104749-1560	WP-211 F-7 ~F-8	9 460 610 159	104769-2025	WP-211 I-3 ~I-4
9 460 610 121	104749-1570	WP-211 F-9 ~F-10	9 460 610 160	104769-2061	WP-211 I-5 ~I-7
9 460 610 124	104749-2142	WP-211 G-1 ~G-2	9 460 610 161	104769-2071	WP-211 I-8 ~I-9
9 460 610 126	104748-0173	WP-211 D-7 ~D-9	9 460 610 162	104769-2110	WP-211 I-12~I-13
9 460 610 127	104740-1022	WP-211 B-4	9 460 610 166	104760-2232	WP-211 H-13
9 460 610 128	104749-2082	WP-211 F-13	9 460 610 167	104760-2263	WP-211 H-16
9 460 610 129	104749-2180	WP-211 G-4	9 460 610 168	104740-3480	WP-211 B-11
9 460 610 131	104740-1121	WP-211 B-5	9 460 610 169	104740-3500	WP-211 B-12
9 460 610 134	104740-4460	WP-211 C-1	9 460 610 170	104749-4110	WP-211 H-4
9 460 610 135	104740-4500	WP-211 C-1	9 460 610 172	104749-0040	WP-211 E-10
9 460 610 136	104740-4520	WP-211 C-2	9 460 610 174	104749-1841	WP-211 F-11
9 460 610 137	104740-4570	WP-211 C-2	9 460 610 175	104749-1990	WP-211 F-12
9 460 610 138	104740-4580	WP-211 C-3	9 460 610 176	104740-2042	WP-211 B-8 ~B-9
9 460 610 139	104740-4701	WP-211 C-3	9 460 610 177	104760-2011	WP-211 M-9
9 460 610 140	104740-4770	WP-211 C-4 ~C-5	9 460 610 179	104749-1600	WP-211 M-1
9 460 610 141	104740-4800	WP-211 C-6 ~C-7	9 460 610 180	104748-0060	WP-211 K-5

Table of Contents (DKKC No. — BOSCH No.)

DKKC No.	BOSCH No.	Location	DKKC No.	BOSCH No.	Location
104760-2133	9 460 610 087	WP-211 H-10			
104760-2160	9 460 610 088	WP-211 H-11			
104760-2230	9 460 610 089	WP-211 H-12			
104760-2232	9 460 610 166	WP-211 H-13			
104760-2240	9 460 610 090	WP-211 H-14			
104760-2242	9 460 610 091	WP-211 H-15			
104760-2263	9 460 610 167	WP-211 H-16			
104769-2023	9 460 610 092	WP-211 I- 1 ~I- 2			
104769-2025	9 460 610 159	WP-211 I- 3 ~I- 4			
104769-2061	9 460 610 160	WP-211 I- 5 ~I- 7			
104769-2071	9 460 610 161	WP-211 I- 8 ~I- 9			
104769-2103	9 460 610 200	WP-211 I-10~I-11			
104769-2110	9 460 610 162	WP-211 I-12~I-13			
104769-2113	9 460 610 201	WP-211 I-14~I-15			